



F-1022MAK(-C)(-CB)

Modular Ice Machine Slim-Line Series



F-1022MAK(-C)
F-1022MAK-CB
02/11/26
Item # 13108K

W x D x H
22" x 24" x 26"

F-1022MAK
Air-Cooled Flaker
Shown on optional bin B-500

F-1022MAK-C
Air-Cooled Cubelet

F-1022MAK-CB
Air-Cooled Cubelet
with Black Front Panel



Features

- ▶ Durable stainless steel exterior
- ▶ Advanced CleanCycle24™ design
- ▶ Environmentally friendly R290 hydrocarbon refrigerant
- ▶ Stainless steel auger with greaseless bearing



- Flaker - Up to 915 lbs. of ice production per 24 hrs.
- Cubelet - Up to 865 lbs. of ice production per 24 hrs.
- Ultrasonic bin control for easy cleaning and reliability
- 2 second flush cycle every hour
- Flush cycle removes sediment for cleaner ice
- Mount two units, side-by-side, in only 44" of floor space for double the amount of ice production

Available on Bins:

B-250SF B-500SF B-800SF B-1150SS B-1500SS*
B-300SF B-700SF B-900SF B-1300SS B-1650SS*

Top kit may be required; See Bin Spec Sheets. *Two unit application only.

Warranty:

3 Year Parts & Labor on entire machine. 5 Year Parts on Compressor; air-cooled condenser coil. Valid in United States, Canada, Puerto Rico and U.S. Territories. Contact factory for warranty in other countries.

Shipping: (LxWxH) 32" x 26.5" X 32" Volume: 15.7ft³

Condenser	Model	ICE PRODUCTION		WATER USAGE		ELECTRICAL					Heat Rejection BTU/hr.	Refrigerant Charge Amount	Net / Ship Weight (lbs.)
		Air / Water Temp Lbs. per 24 hours 70°/ 50°F 90°/ 70°F		Potable Gal. per 100 lbs. 90°/ 70°F	Condenser Gal. per 100 lbs. 90°/ 70°F	kWh Used per 100 lbs. 90°/ 70°F	Min. Circuit/Max. Fuse Size	Amperage	Voltage	Circuit Wires (including ground)			
Air	F-1022MAK	915	705	12.0	N/A	4.19	20A	12.5A	115V/60/1	3	10,300	2 lbs. 4.2 oz.	183 / 192
Air	F-1022MAK-C	865	660	12.0	N/A	4.5	20A	12.5A	115V/60/1	3	10,300	2 lbs. 4.2 oz.	183 / 192
Air	F-1022MAK-CB	865	660	12.0	N/A	4.5	20A	12.5A	115V/60/1	3	10,300	2 lbs. 4.2 oz.	183 / 192

Power cord not included

Cube Dimensions*

Flaked
F-1002MAK

Cubelet
F-1002MAK-C/-CB

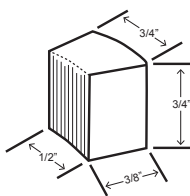

* approximate size in inches, image not to scale

Operating Limits

- Ambient Temp Range 45 - 100°F
- Water Temp Range 45 - 90°F
- Water Pressure 10 - 113 PSIG
- Voltage Range 108-127V
- If GFCI is required, a GFCI breaker MUST be used in lieu of GFCI receptacle

Service

- Panels easily removed and all components accessible for service.
- Allow 24" (61 cm) clearance at top for removal of auger and 6" (15 cm) clearance at rear and sides for proper air circulation and ease of maintenance/service.

Plumbing

- Icemaker Water Supply Line: Minimum 1/4" Nominal ID Copper Water Tubing or Equivalent
- Icemaker Drain Line: Minimum 3/4" Nominal ID Hard Pipe or Equivalent

Hoshizaki reserves the right to change specifications without notice.



F-1022MAK(-C)(-CB)

Modular Ice Machine
Slim-Line Series

F-1022MAK(-C)
F-1022MAK-CB
02/11/26
Item # 13108K

FRONT VIEW

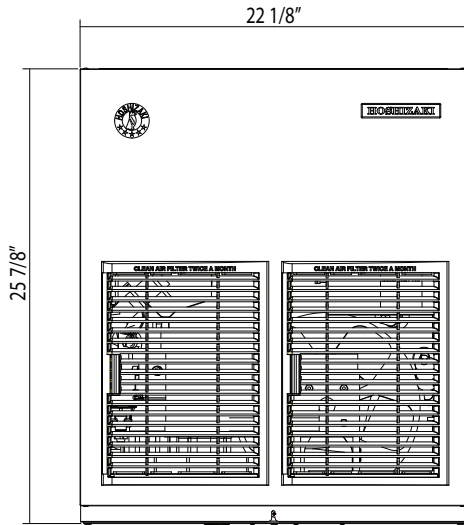

SIDE VIEW

mm
[inch]

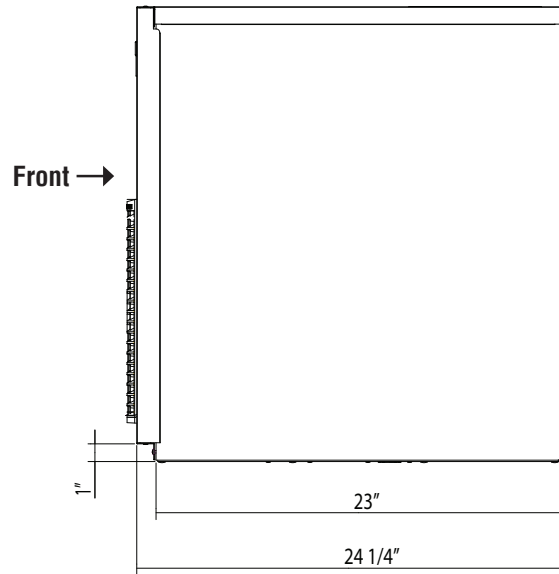

REAR VIEW

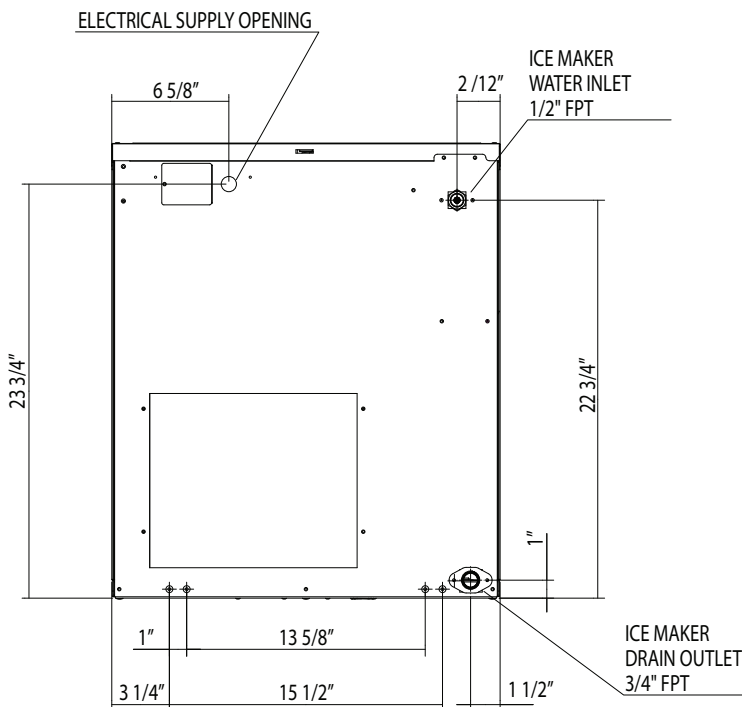

BOTTOM VIEW

