



# HXF1A/2A-FGE

Full Glass Door(s), Laboratory/Pharmacy Freezer  
Certified to NSF/ANSI 456 Vaccine Storage Standard



HXF1A/2A-FGE  
06/04/26  
Item # 13600



HXF1A-FGE



HXF2A-FGE

### Monitoring display with user-friendly interface

- o 7-inch capacitive multi-touch digital display is user-programmable with temperature in °C or °F
- o Intuitive event and data logging capability with easy download via convenient, front access USB port

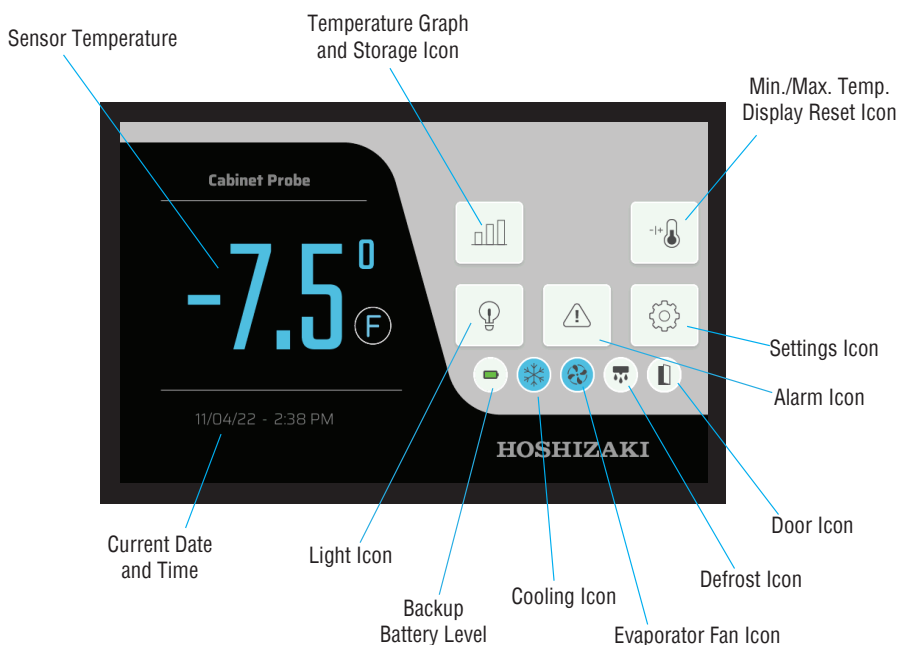

- **Designed for performance**
  - o Modular refrigeration system with microprocessor controller provides reliable performance
  - o Thermostatic Expansion Valve (TXV) system quickly and effectively regulates refrigerant flow to control temperatures
  - o Unique ducted air distribution system maintains uniform temperature for consistent cabinet temperatures at each shelf level
  - o Auto-evaporating condensate pan means no overflow or mess
- **Durable construction**
  - o Stainless steel interior and exterior front, sides and top provide resistance to rust and corrosion and is easy to clean
  - o Evaporator coils are epoxy electrocoated to help fight corrosion
  - o Heavy duty, easy to roll casters (two with locks)
- **Energy efficient and sustainable**
  - o Energy efficient LED lights (full length)
  - o Environmentally friendly R290 hydrocarbon refrigerant
  - o 2 3/8" of CFC-free foamed in place insulation
- **Product Safety**
  - o Audible and visual alarms for high/low temperature, door open, power failure, and low battery
  - o Dry contacts for remote alarming
  - o Standard access port for third party temperature monitoring
- **Heavy-duty door(s) for ease of use**
  - o Multi-pane argon filled glass doors are energy efficient
  - o ADA-compliant full-length flush mount handles
  - o Self-closing doors stay open at 90 degrees for easy product loading
  - o Heavy-duty stainless steel hinges
  - o Locks standard on all doors



# HXF1A/2A-FGE

HXF1A/2A-FGE  
06/04/26  
Item # 13600

## HXF1A-FGE

## HXF2A-FGE

### Interior

Height	60.24"	
Shelf-dimensions (WxDxH)	21.25" x 26.00"	
Nominal capacity	23.10 ft <sup>3</sup>	50.37 ft <sup>3</sup>

### Exterior

W x D x H (height with 4" casters)	27.5" x 34.5" x 79.5"	55" x 33.5" x 79.5"
Door Opening (WxH)	21.75" x 59.25"	
Clearance	Side: 0" Top: 0" Rear: 3"	
Field reversible doors		

### Electrical

Voltage	115V/60/1	
HACR/Breaker	15.0 Amps	
Voltage Range	104-126V	
Electrical Connection (NEMA)	5-15P	
• 10 ft. cord/hospital grade plug		
Ambient Temp. Range	45°F - 80.6°F / 7.2°C - 27°C	
Control Set Point Range	-10°F - +12°F / -23.3°C - 11.1°C	

### System performance

Amperage	9	9.5
Energy consump. (kWh/day) @ASHRAE/Energy Star®	1.25 / (7.99)	3.47
Heat rejection (BTU/Hr.) @NSF/Energy Star®	317 (639)	513
Approx. nominal compres. BTU/HR(HP)	770(1/4HP)	1545(1/2HP)
Refrigerant / charge amount	R290/(4.6oz)	R290/(4.9oz)

### Shipping

Shipping size (L x W x H)	35.5" x 31.5" x 81"	58" x 37.5" x 81"
Approximate shipping weight	382 lbs.	623 lbs.

### Alarming

High and low product temperature alarm	audible and visual, user programmable set points in F° or C°
Power failure alarm	audible and visual
Door ajar alarm	audible and visual
Probe error alarm	probe errors are detected by MC controller
Alarm volume	0-10 scale
Low battery alert	audible and visual
Back-up battery status	shows voltage level
Temperature log	settable continuous recording of data
Remote contacts	No/NC standard, located behind front panel

### Data logging

Information log	graphs or displays temperature data and displays chronological event data up to 3 months of data.
Data export	USB export capabilities

### Controls

Temperature display	7" LCD capacitive touchscreen digital temperature display available in user-programmable F° or C°
Information log	up to 3 months of data/ 170,661 records
3rd party probe access	bottom lower left rear of cabinet; co-molded liquid tight plug (nylon & elastomer) which can be pierced by round wire
Product temperature display probe	(1) hard wired (±0.7°F , ±0.4°C)
Temperature probe calibration	top probe calibration in 0.1° increments
Password protection PIN	4-digit password to prevent interface setting/selection changes
Date and time	programmable
Product simulation bottle size	20ml
Refrigeration and defrost probes	NTC thermistor type
Refrigeration cycle with probe error	multiple detection functions
Programmable operating range	-10°F - +12°F / -23.3°C - -11.1°C
Factory preset	-5°F / -21°C

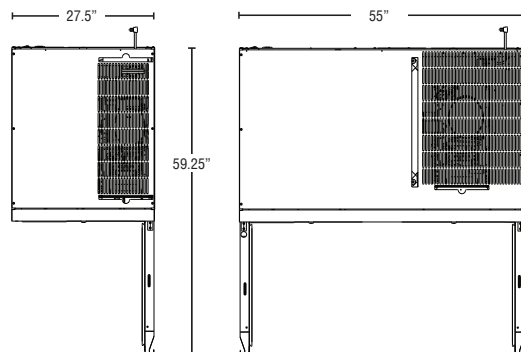
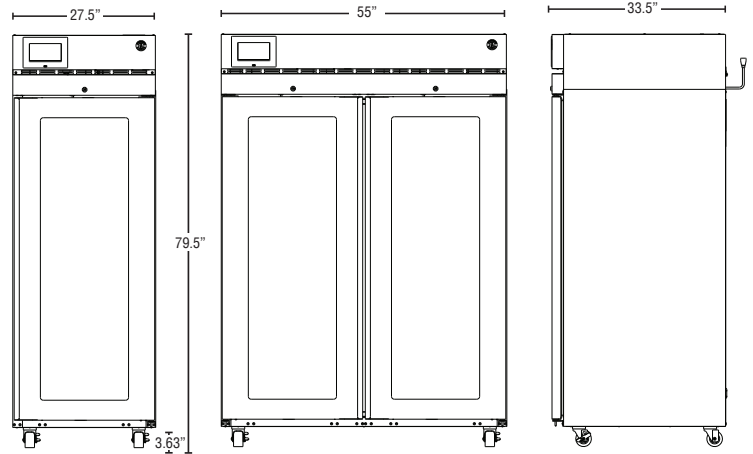

### Warranty

Seven year warranty on labor, parts, and compressor.  
Valid in United States, Canada, Puerto Rico and U.S. Territories.  
For more information, please visit:  
[hoshizaki.com/support/warranty/](http://hoshizaki.com/support/warranty/)