



KM-322/522/622MAK

SLIM-LINE MODULAR CRESCENT CUBER



KM-322/522/622MAK
04/06/26
Item # 13260K

W x D x H
22" x 27^{3/8}" x 28"

Air-Cooled

- KM-322MAK ★
- KM-522MAK ★
- KM-622MAK ★





Air-cooled model
shown on optional bin: B-300



Features

- ▶ Individual crescent cube
- ▶ Factory-installed ultrasonic bin control can be adjusted on site
- ▶ Environmentally friendly R290 hydrocarbon refrigerant
- ▶ Simple, one-hour cleaning process 

- Durable construction with fewer parts
- Self-diagnostic programming automatically adjusts to changing conditions
- Snap fit parts for easy cleaning
- Stainless steel double-sided evaporator
- CycleSaver™ design 
- EverCheck™ alert system 
- Removable air filters

Available on Bins/Dispensers:

B-250SF	B-500/SF	B-800SF	B-1150SS	DB-130H
B-300SF	B-700SF	B-900SF	B-1300SS	DB-200H
				DM-200B

Top kit may be required. See Bin Spec Sheets.

Warranty:

3 Year Parts & Labor on entire machine 5 Year Parts & Labor on evaporator
5 Year Parts on Compressor; air-cooled condenser coil
Valid in United States, Canada, Puerto Rico and U.S. Territories. Contact factory for warranty in other countries.

Shipping: (LxWxH) 33.5" x 25.88" X 34.6" Volume: 17.36ft³



Condenser	Model	ICE PRODUCTION		WATER USAGE			ELECTRICAL						
		Air / Water Temp Lbs. per 24 hours 70°/ 50°F	90°/ 70°F	Potable Gal. per 100 lbs. 90°/ 70°F	Condenser Gal. per 100 lbs. 90°/ 70°F	kWh Used per 100 lbs. 90°/ 70°F	Min. Circuit/ Max. Fuse Size	Amperage	Voltage	Circuit Wires (including ground)	Heat Rejection BTU/hr.	Refrigerant Charge Amount	Net / Ship Weight (lbs.)
Air	KM-322MAK	489	400	18.0	N/A	4.9	20A	9.7A	115V/60/1	3	7,700	5.1 oz.	145 / 175
Air	KM-522MAK	548	445	17.0	N/A	5.15	20A	10.8A	115V/60/1	3	8,400	5.3 oz.	145 / 175
Air	KM-622MAK	673	540	17.0	N/A	5.25	20A	14.6A	115V/60/1	3	8,400	5.3 oz.	150 / 180

KMEdge™ Cube Dimensions*

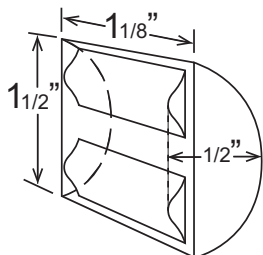

* approximate size in inches, image not to scale

Operating Limits

- Ambient Temp Range 45 - 100°F
- Water Temp Range 45 - 90°F
- Water Pressure 10 - 113 PSIG
- Voltage Range 104 - 127V
- If GFCI is required, a GFCI breaker MUST be used in lieu of GFCI receptacle

Service

- Panels easily removed and all components accessible for service.
- Removable/cleanable air filters. (Air-cooled model only)
- Allow 6" (15 cm) clearance at rear, sides, and top for proper air circulation and ease of maintenance/service.

Plumbing

- Icemaker water supply line: minimum 1/4" nominal ID copper water tubing or equivalent
- Icemaker drain line: minimum 3/4" nominal ID hard pipe or equivalent Water-Cooled Model (Lines Must Be Independent of Icemaker)
- Condenser water supply line: minimum 1/4" nominal ID copper water tubing or equivalent
- Condenser drain/return line: minimum 1/4" nominal ID hard pipe (open drain system) or copper water tubing (closed loop system) or equivalent

Water Filter

Please refer to water filter specification sheet for recommendations.



KM-322/522/622MAK

SLIM-LINE MODULAR CRESCENT CUBER

KM-322/522/622MAK

04/06/26

Item # 13260K

FRONT VIEW

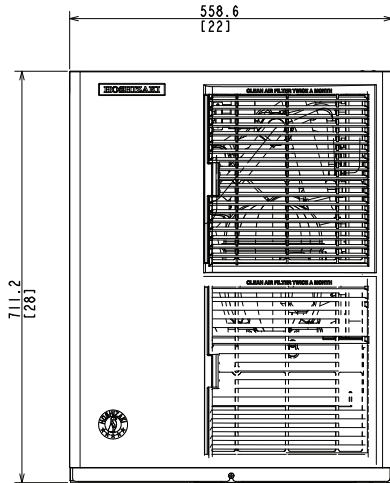

SIDE VIEW

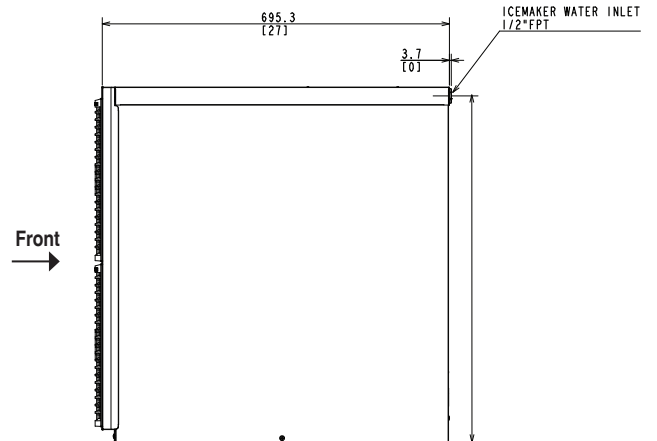

REAR VIEW

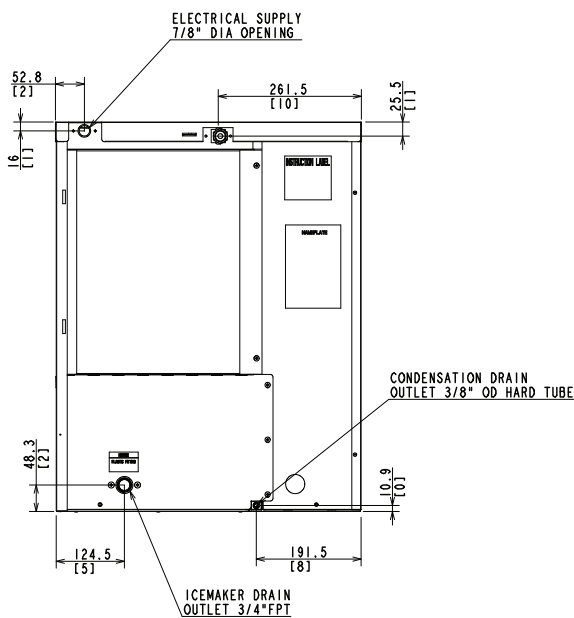

BOTTOM VIEW

