



KM-530MAK

MODULAR CRESCENT CUBER



KM-530MAK
04/28/26
Item #13683K

W x D x H
30" x 24" x 22"

Air-Cooled
KM-530MAK



Air-cooled model shown
on Lancer Dispenser



Air-cooled model shown
on DB-200H Bin



Air-cooled model shown
on BD-500SF

KMEdge™ Cube Dimensions*

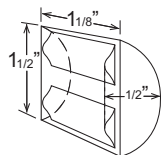



* approximate size in inches, image not to scale



Item #: _____
Project: _____
Qty: _____
AIA#: _____

Features

- ▶ Individual crescent cube
- ▶ Factory-installed ultrasonic bin control can be adjusted on site
- ▶ Environmentally friendly R290 hydrocarbon refrigerant
- ▶ Simple, one-hour cleaning process 

- Optimized for use with ice and beverage dispenser
- Durable construction with fewer parts
- Self-diagnostic programming automatically adjusts to changing conditions
- Snap fit parts for easy cleaning
- Stainless steel double-sided evaporator
- CycleSaver™ design 
- EverCheck™ alert system 
- Removable air filters (air-cooled model only)

Available on Bins:

B-250SF **BD-500SF**** **B-800SF** **B-1150SS** **DB-130H**
B-500SF **B-700SF** **B-900SF** **B-1300SS** **DB-200H**

Top kit may be required. See bin spec sheets. **BD bins recommended

Warranty:

3 Year Parts & Labor on entire machine. 5 Year Parts & Labor on Evaporator. 5 Year Parts on Compressor; air-cooled condenser coil. Valid in United States, Canada, Puerto Rico and U.S. Territories. Contact factory for warranty in other countries.

Shipping: (LxWxH) 33.75" x 33.25" X 28" Volume: 18.18ft³

Condenser	Model	ICE PRODUCTION		WATER USAGE		ELECTRICAL							
		Air / Water Temp Lbs. per 24 hours 70°/50°F 90°/70°F		Potable Gal. per 100 lbs. 90°/70°F	Condenser Gal. per 100 lbs. 90°/70°F	kWh Used per 100 lbs. 90°/70°F	Min. Circuit/ Max. Fuse Size	Amperage	Voltage	Circuit Wires (including ground)	Heat Rejection BTU/hr.	Refrigerant Charge Amount	Net / Ship Weight (lbs.)
Air	KM-530MAK	545	424	25.0	N/A	5.3	20A	10.7A	115V/60/1	3	8,600	5.3 oz.	156 / 176

Operating Limits

- Ambient Temp Range 45 - 100°F
- Water Temp Range 45 - 90°F
- Water Pressure 10 - 113 PSIG
- Voltage Range 104 - 127V
- If GFCI is required, a GFCI breaker MUST be used in lieu of GFCI receptacle

Service

- Panels easily removed and all components accessible for service.
- Removable/cleanable air filters. (Air-cooled model only)
- Allow 6" (15 cm) clearance at rear, sides, and top for proper air circulation and ease of maintenance/service.

Plumbing

- Icemaker Water Supply Line: Min. 1/4" Nominal ID Copper Water Tubing or Equivalent
- Icemaker Drain Line: Min. 3/4" Nominal ID Hard Pipe or Equivalent
- Water-Cooled Model (Lines Must Be Independent of Icemaker)
- Condenser Water Supply Line: Minimum 1/4" Nominal ID Copper Water Tubing or Equivalent
- Condenser Drain/Return Line: Minimum 1/4" Nominal ID Hard Pipe (open drain system) or Copper Water Tubing (closed loop system) or Equivalent

Accessories

- HS-2148, DB Top Kit
- HS-5562, Remote Monitoring System
- HS-5767, BioSure Clean Ice Ozone System
- HS-5734, Side-Breathing Kit
- H9320-51, Single Water Filter Kit

Hoshizaki reserves the right to change specifications without notice.



KM-530MAK

MODULAR CRESCENT CUBER

KM-530MAK
04/28/26
Item #13683K

mm
inch

FRONT VIEW

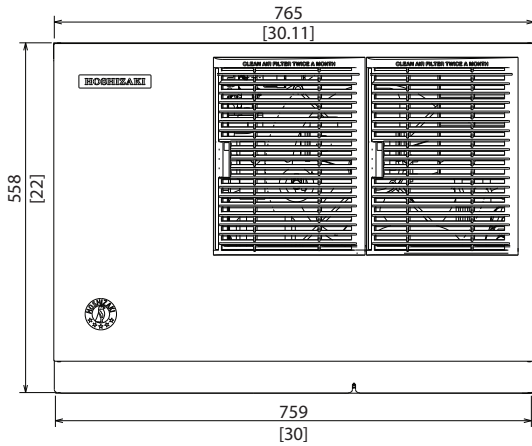

SIDE VIEW

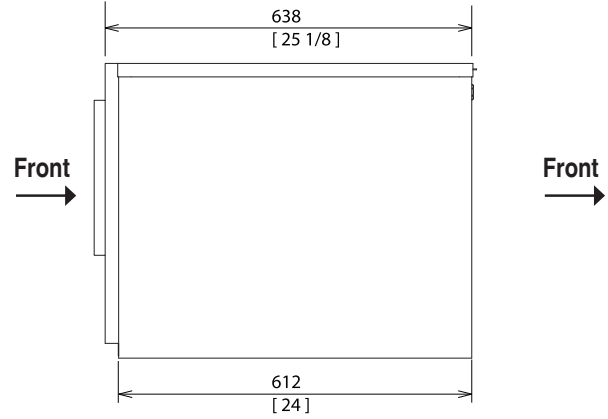

REAR VIEW

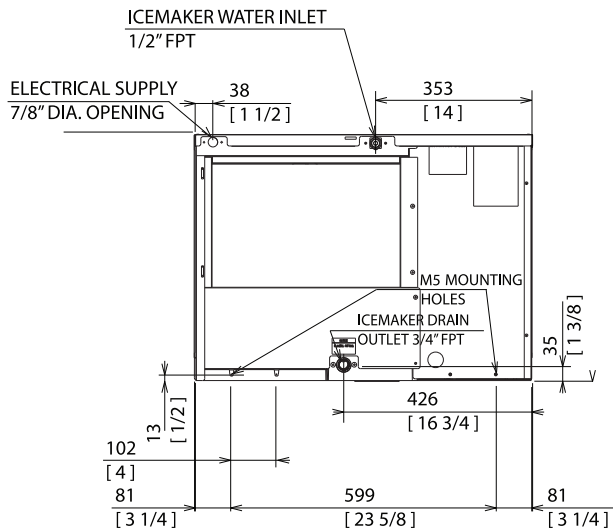

BOTTOM VIEW

