



WLR93B-D2/-D4

Worktop 93" Side Mount Refrigerator
with Two Doors/Two Drawers, with One Door/Four Drawers



WLR93B-D2
05/20/26
Item # 13706

W x D x H

97" x 33.25" x 40.25"*
Work Height 36"
*with 6" casters



WLR93B-D2



WLR93B-D4



Dimensions / Capacity

Interior Storage Capacity (CF) (AHAM)	30.17 ft ³
Overall Width x Depth (including 1" bumper)	93" x 33.25"
Height (including 6" casters)	40.25"
Door Opening Width x Height	22.5" x 23"
Depth with Door Fully Open (including 1" bumper)	57.75"
Depth with Drawer Fully Open (including 1" bumper)	57.5"
Adjustable shelves / Shelf Dimensions (W x D)	6 / 24.75" x 25.5"
Crated Weight	523 / 568 lbs.
Crated Length x Width x Height	95.25" x 34.5" x 40"

Three-Section WLR93B-D2/-D4

Electrical / Refrigeration

Voltage	115/60/1
HACR Breaker	15.0 Amps
Electrical Connection (NEMA)	5-15P
Voltage Range	104-126
Ambient Temp. Range	45° to 100°F
Control Setpoint Range	28° to 45°F
Amperage	5
Energy Consumption (kWh/day) @NSF	1.879
Heat Rejection (BTU/Hr.) @NSF	448
Approx. Nominal Compres. BTU/HR (HP)	2431 (1/3HP)
Refrigerant / Charge Amount (oz)	R290 (2.4 oz)

Three-Section WLR93B-D2/-D4

Options

- 2" Casters (HS-5037, set of 4)
- 4" Casters (HS-5035, set of 4)
- Foot pedal kit (HS-5555, Lft hinge)
- Foot pedal kit (HS-5556, Rt hinge)
- Overshelves (HS-5229 single)
- Overshelves (HS-5228 double)
- Addtl. Epoxy Shelves (HS-5579, 1pk)
- Addtl. Stainless Shelves (HS-5580, 1pk)
- Drawer divider bar (HS-4007, Vertical)
- Drawer divider bar (HS-5691, Horizontal)
- Drawer liner (HS-5740)



Seven year warranty on labor, parts, and compressor. Valid in United States, Canada, Puerto Rico and U.S. Territories.

For more information, please visit hoshizakiamerica.com/support/warranty/

Item #: _____

Project: _____

Qty: _____

AIA#: _____

Features

- ▶ Front breathing air flow design allows for 1" of rear wall clearance
- ▶ Stainless steel exterior front, sides, and top with stainless steel interior sides, back, and floor
- ▶ Engineered to maintain NSF-7 temperatures in 100°F ambient
 - Environmentally friendly R290 hydrocarbon refrigerant
 - Cabinet and drawers are insulated with 2" CFC free, foamed in place polyurethane
 - Drawer slides are constructed of 14 gauge stainless steel with acetal rollers
 - Drawer slides have a dynamic load capacity of 250 lbs.
 - Drawer frames are formed of 14 gauge stainless steel and securely fastened in the cabinet
 - Drawers will accommodate (2) 12 x 20 x 6" deep pans (pans by others)
 - Extruded aluminum flush mount door/drawer handle
 - Two epoxy coated shelves per section is standard
 - Shelves hold a full- size sheet pan & 120 lbs. capacity
 - Anodized aluminum shelf supports adjustable in 1/2" increments
 - Field reversible doors with magnetic snap-in gaskets
 - Magnetic door gaskets are easily removable for cleaning
 - Digital temperature display
 - Removable air filter for easy cleaning
 - Hot gas condensate removal
 - Mullion heaters for reduced condensation
 - E-coated evaporator coil
 - Standard with 4" casters (three with brakes)
 - 10 ft. cord and plug

Door or drawer can be located in any section of the cabinet. Location must be indicated at time of ordering.

If GFCI is required, a GFCI breaker MUST be used in lieu of GFCI receptacle

Hoshizaki reserves the right to change specifications without notice.



WLR93B-D2/-D4

Worktop 93" Side Mount Refrigerator
with Two Doors/Two Drawers, with One Door/Four Drawers



WLR93B-D2
05/20/26
Item # 13706

FRONT VIEW

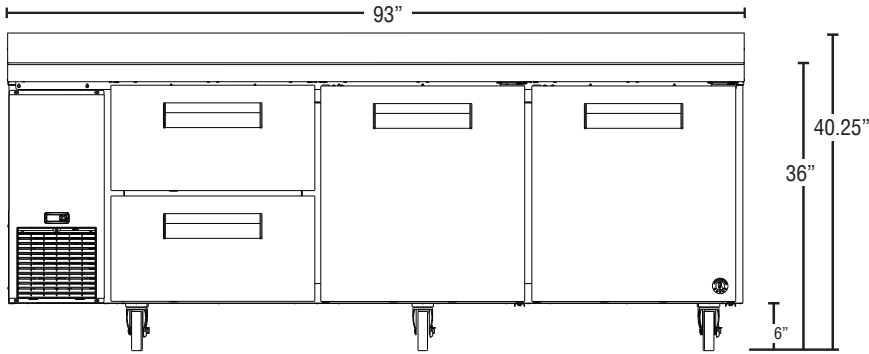

WLR93B-D2

SIDE VIEW

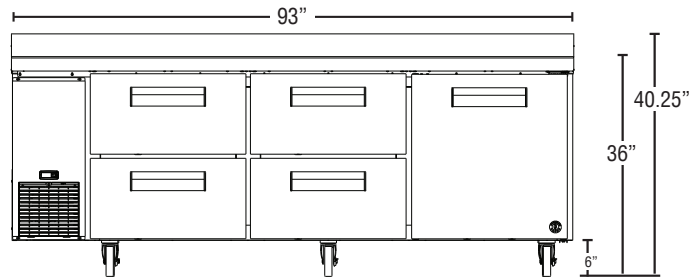
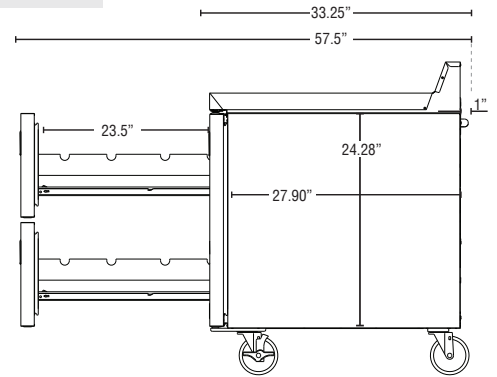

WLR93B-D4

PLAN VIEW

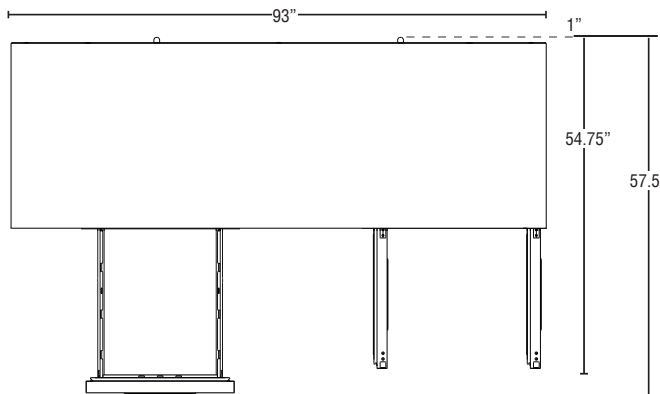

WLR93B-D2

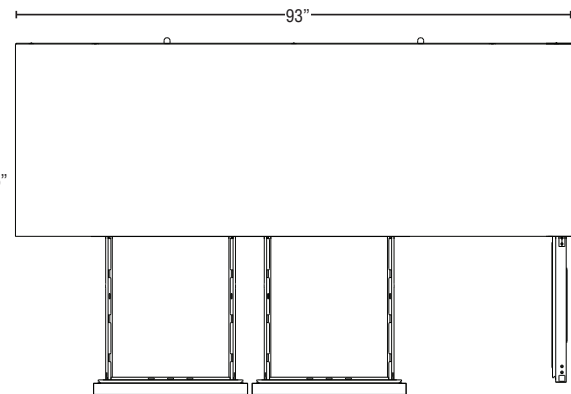

WLR93B-D4

Cabinet Construction

The exterior cabinet top, front, and sides, are constructed of high quality stainless steel. The exterior back and bottom are constructed of coated steel. The cabinet interior features stainless steel back, sides, and floor with an ABS top. One heavy duty epoxy coated shelf per section is standard. Mounted on anodized aluminum pilasters the shelves are adjustable in 1/2" increments. Cabinet walls and doors are insulated with 2" of environmentally friendly, CFC free, foamed in place polyurethane. 6" polyolefin, stem casters (two with brakes) are standard.

Door Construction

Doors are constructed of high grade stainless steel exterior with an ABS interior liner and are insulated with 2" CFC free, foamed in place polyurethane. Hoshizaki's exclusive "stepped" design protects the gasket while product is removed from the cabinet. Doors are provided with a one piece, extruded aluminum, flush mount handle. Spring assisted self-closing doors are equipped with a stay open feature past 90° degrees. Snap-in magnetic door gaskets are durable and easily removed for cleaning. Field reversible door hinging is standard.

Drawer Construction

Drawer fronts are constructed of high grade stainless steel with stainless steel interior and are insulated with 2" CFC free, foamed in place polyurethane. Each drawer accommodates (2) 12" x 20" x 6" deep pans (pans by others). Drawer frames are formed of 14 gauge stainless steel all welded construction and securely fastened in the cabinet. The drawer slides are constructed of heavy duty 14 gauge stainless steel and durable acetal rollers with stainless steel ball bearings to prevent metal to metal contact. The drawer slides have a dynamic load capacity of 250 lbs. and have been life tested (fully loaded) three hundred thousand cycles without showing significant wear. The flush mount handles are constructed of extruded aluminum. Snap-in magnetic drawer gaskets are durable and easily removed for cleaning.

Refrigeration System

The high efficiency refrigeration system is self-contained with an E-coated evaporator for extended life. Condensate removal is accomplished with an energy efficient non-electric evaporation system. A capillary tube controls the flow of environmentally friendly R290 refrigerant through the evaporator. Refrigeration system utilizes an "off cycle" defrost to eliminate any ice on the evaporator coil. 115 volt units are equipped with a ten foot cord and plug (20.0 amps or less).