



HOSHIZAKI

Service Manual

Self-Contained Cuber

Models

AM-50BAK

AM-50BAK-DS

AM-50BAK-AD

AM-50BAK-ADDS



⚠ WARNING

Only qualified service technicians should install and service the appliance. To obtain the name and phone number of your local Hoshizaki Certified Service Representative, visit www.hoshizakiamerica.com. No service should be undertaken until the technician has thoroughly read this Service Manual. Failure to service and maintain the appliance in accordance with this manual will adversely affect safety, performance, component life, and warranty coverage and may result in costly water damage. Proper installation is the responsibility of the installer. Product failure or property damage due to improper installation is not covered under warranty.

Hoshizaki provides this manual primarily to assist qualified service technicians in the service of the appliance.

Should the reader have any questions or concerns which have not been satisfactorily addressed, please call, send an e-mail message, or write to the Hoshizaki Technical Support Department for assistance.

Phone: 1-800-233-1940; (770) 487-2331

E-mail: tech-support@hoshizaki.com

HOSHIZAKI AMERICA, INC.

618 Highway 74 South

Peachtree City, GA 30269

Attn: Hoshizaki Technical Support Department

NOTE: To expedite assistance, all correspondence/communication **MUST** include the following information:

- Model Number _____
- Serial Number _____
- Complete and detailed explanation of the problem.

IMPORTANT

This manual should be read carefully before the appliance is serviced. Read the warnings and guidelines contained in this manual carefully as they provide essential information for the continued safe use, service, and maintenance of the appliance. Retain this manual for any further reference that may be necessary.

CONTENTS

Important Safety Information	4
I. Construction and Water/Refrigeration Circuit Diagram	9
A. Construction	9
B. Water/Refrigeration Circuit Diagram	10
II. Sequence of Operation	11
A. Sequence of Operation Flow Chart	11
1. Icemaker Flow Chart	11
2. Bin Control Shutdown Flow Chart	12
III. Service Diagnosis, Refrigeration Circuit Service, and Component Service	13
A. Safety Precautions When Servicing Précautions à prendre lors de l'entretien	13
1. English	13
2. Français	18
B. Service Diagnosis	23
1. Diagnostic Procedure	24
2. Main Control Board Check	29
3. Bin Control Thermistor Check	31
4. Evaporator Thermistor Check	32
5. Main Control Board and Thermistor Control Board Layout	33
6. Main Control Board Settings and Adjustments	35
7. LED Lights	36
8. Control Switch	36
9. Diagnostic Tables	37
C. Refrigeration Circuit Service	40
D. Component Service	44
IV. Maintenance	46
A. Maintenance Schedule	46
B. Optional Drain Pump HS-5061	47
V. Preparing the Appliance for Periods of Non-Use	48
VI. Decommissioning and Disposal	50
VII. Technical Information	54
A. Specification and Performance Data	54
1. AM-50BAK(-DS)	54
2. AM-50BAK-AD(-ADDS)	55
B. Wiring Diagrams	56
1. AM-50BAK(-DS)(-AD)(-ADDS)	56
2. HS-5061 Optional Drain Pump	57

Important Safety Information

Throughout this manual, notices appear to bring your attention to situations which could result in death, serious injury, damage to the appliance, or damage to property.

	R-290 Class A3 Flammable Refrigerant Used
⚠ DANGER	Indicates a hazardous situation that, if not avoided, will result in death or serious injury.
⚠ WARNING	Indicates a hazardous situation that, if not avoided, could result in death or serious injury.
NOTICE	Indicates a situation that, if not avoided, could result in damage to the appliance or property.
IMPORTANT	Indicates important information about the use and care of the appliance.

⚠ DANGER

Risk of Fire or Explosion Flammable Refrigerant Used

- | | |
|--|---|
| <ul style="list-style-type: none"> • Only qualified service technicians should install and service the appliance. Qualified service technicians are those having the appropriate technical training and experience necessary to be aware of hazards to which they are exposed in performing a task and of measures necessary to minimize the danger to themselves or other persons. • No service should be undertaken until the technician has thoroughly read this Service Manual. All safety precautions must be followed. • This appliance to be installed in accordance with the Safety Standard for Refrigeration Systems ANSI/ASHRAE 15. • Follow handling instructions carefully in compliance with national regulations. • Do not use mechanical devices or other means to accelerate the defrosting process or to clean, other than those recommended by the manufacturer. • Do not puncture refrigerant tubing. Risk of fire or explosion due to puncture of refrigerant tubing; follow handling instructions carefully. | <ul style="list-style-type: none"> • Servicing shall be done by trained service personnel with certified competence in handling flammable refrigerants to minimize the risk of possible ignition due to incorrect parts or improper service. • Component parts shall be replaced with like components. So as to minimize the risk of possible ignition due to incorrect parts. • Dispose of properly in accordance with federal or local regulations. • Do not pierce or burn. • Be aware that refrigerants may not contain an odor. • Do not damage the refrigeration circuit. • See nameplate for R-290 refrigerant charge: <ul style="list-style-type: none"> • If greater than 114 g (4 oz.), do not install in public corridor or lobby. • If greater than 152 g (5.3 oz.), do not install within 6 m (20 ft) of open flame. • The appliance shall be stored in a room without continuously operating ignition sources (for example: open flames, an operating gas appliance, or an operating electric heater). |
|--|---|

⚠ DANGER continued

- Do not place any potential ignition sources in or near the appliance.
- Keep clear of obstruction all ventilation openings in the appliance enclosure or in the structure for building-in.
- No potential sources of ignition are to be used in the searching for or detection of refrigerant leaks.
- Do not use electrical appliances inside the appliance unless they are of the type recommended by the manufacturer.
- Do not store explosive substances such as aerosol cans with a flammable propellant in this appliance.
- Check that cabling will not be subject to wear, corrosion, excessive pressure, vibration, sharp edges, or any other adverse environmental effects. The check shall also take into account the effects of aging or continual vibration from sources such as compressors or fans.
- Ensure that the area is in the open or that it is adequately ventilated before breaking into the system or conducting any hot work. A degree of ventilation shall continue during the period that the work is carried out. The ventilation should safely disperse any released refrigerant and preferably expel it externally into the atmosphere.

**Risque D'Incendie ou D'Explosion
Fluide Frigorigène Inflammable Utilisé**

- Seuls des techniciens de service qualifiés doivent installer et entretenir l'appareil. Les techniciens de service qualifiés sont ceux qui possèdent la formation technique et l'expérience nécessaires pour être conscients des dangers auxquels ils sont exposés dans l'accomplissement d'une tâche et des mesures nécessaires pour réduire au minimum le danger pour eux-mêmes ou pour d'autres personnes.
- Aucune opération d'entretien ne doit être entreprise avant que le technicien n'ait lu attentivement ce manuel. Toutes les précautions de sécurité doivent être suivies.
- Cet appareil doit être installé conformément à la norme de sécurité pour les systèmes de réfrigération ANSI/ASHRAE 15.
- Suivez attentivement les instructions de manutention conformément aux règlements nationaux.
- Ne pas utiliser de dispositifs mécaniques ou d'autres moyens pour accélérer le processus de dégivrage ou pour nettoyer, autres que ceux recommandés par le fabricant.
- Ne pas perforer la conduite de fluide frigorigène. Risque d'incendie ou d'explosion en cas de perforation d'une canalisation de fluide frigorigène; suivez attentivement les instructions de manutention.
- L'entretien doit être effectué par du personnel formé et certifié pour la manipulation de réfrigérants inflammables afin de réduire au minimum le risque d'inflammation dû à des pièces incorrectes ou à un entretien inadéquat.
- Les pièces doivent être remplacées par des pièces similaires, de manière à réduire au minimum le risque d'inflammation dû à des pièces incorrectes.

⚠ DANGER Continué

- Mettre au rebut conformément aux règlements fédéraux ou locaux.
- Ne pas percer ou brûler.
- Attention, les fluides frigorigènes peuvent ne pas dégager d'odeur.
- Ne pas endommager les composants du circuit de réfrigération.
- Voir plaque signalétique pour la charge de réfrigérant R-290:
 - Si elle est supérieure à 114 g (4 oz.), ne pas l'installer dans un couloir public ou un hall d'entrée.
 - Si elle est supérieure à 152 g (5,3 oz.), ne pas l'installer à moins de 6 m (20 pi) d'une flamme nue.
- L'appareil doit être entreposé dans un local ne contenant pas de sources d'inflammation permanentes (flammes nues, appareil à gaz ou dispositif de chauffage électrique en fonctionnement, par exemple).
- Ne placer aucune source d'inflammation potentielle à l'intérieur ou à proximité de l'appareil.
- Ne pas obstruer les ouvertures de ventilation dans l'enceinte de l'appareil ou dans la structure d'encastrement.
- Aucune source potentielle d'inflammation ne doit être utilisée pour rechercher ou détecter des fuites de réfrigérant.
- Ne pas utiliser d'appareils électriques à l'intérieur de l'appareil, sauf s'ils sont du type recommandé par le fabricant.
- Ne pas entreposer dans cet appareil des substances explosives telles que des bombes aérosols contenant un gaz propulseur inflammable.
- Vérifier que le câblage ne sera pas soumis à l'usure, à la corrosion, à une pression excessive, à des vibrations, à des arêtes vives ou à tout autre effet environnemental négatif. Le contrôle doit également prendre en compte les effets du vieillissement ou des vibrations continues provenant de sources telles que les compresseurs ou les ventilateurs.
- S'assurer que la zone est à l'air libre ou qu'elle est correctement ventilée avant de pénétrer dans le système ou d'effectuer un travail à chaud. Une certaine ventilation doit être maintenue pendant la durée des travaux. La ventilation doit permettre de disperser en toute sécurité tout réfrigérant libéré et, de préférence, de l'expulser dans l'atmosphère.

WARNING

The appliance should be destined only to the use for which it has been expressly conceived. Any other use should be considered improper and therefore dangerous. The manufacturer cannot be held responsible for injury or damage resulting from improper, incorrect, and unreasonable use. Failure to service and maintain the appliance in accordance with this manual will adversely affect safety, performance, component life, and warranty coverage and may result in costly water damage.

To reduce the risk of death, electric shock, serious injury, or fire, follow basic precautions including the following:

- This appliance is not intended for use above 2,000 m (6,561 ft). Installation above 2,000 m (6,561 ft) may adversely affect safety, performance, and component life.
- Wear appropriate personal protective equipment (PPE) when servicing the appliance.
- The appliance must be installed in accordance with applicable national, state, and local codes and regulations. Failure to meet these code requirements could result in death, electric shock, serious injury, fire, or damage.
- The appliance requires an independent power supply of proper capacity. See the nameplate for electrical specifications. Failure to use an independent power supply of proper capacity can result in a tripped breaker, blown fuse, damage to existing wiring, or component failure. This could lead to heat generation or fire.
- Risk of electric shock. Use extreme caution and exercise safe electrical practices.
- Risk of electric shock. Control switch in "OFF" position does not de-energize all loads (optional drain pump).
- Moving parts (e.g., fan blade) can crush and cut. Keep hands clear.

• **THE APPLIANCE MUST BE**

GROUNDING. The appliance is equipped with a NEMA 5-15 three-prong grounding plug  to reduce the risk of potential shock hazards. It must be plugged into a properly grounded, independent 3-prong wall outlet. If the outlet is a 2-prong outlet, it is your personal responsibility to have a qualified electrician replace it with a properly grounded, independent 3-prong wall outlet. Do not remove the ground prong from the power cord and do not use an adapter plug. Failure to follow these instructions may result in death, electric shock, or fire.

- To reduce the risk of electric shock, do not touch the control switch or plug with damp hands.
- To reduce the risk of electric shock, make sure the control switch is in the "OFF" position before plugging in or unplugging the appliance.
- Unplug the appliance before servicing.
- Do not use an appliance with a damaged power cord. The power cord should not be altered, jerked, bundled, weighed down, pinched, or tangled. Such actions could result in electric shock or fire. To unplug the appliance, be sure to pull the plug, not the cord, and do not jerk the cord.
- Do not use an extension cord.
- If the supply cord is damaged, it must be replaced by the manufacturer, its service agent, or similarly qualified persons in order to avoid a hazard. Upon replacement, the GREEN ground wire in the power cord must be connected to the designated grounding screw.
- Do not make any alterations to the appliance. Alterations could result in electric shock, injury, fire, or damage to the appliance.
- Appliance is heavy. Use care when lifting or positioning. Work in pairs when needed to prevent injury or damage.

⚠ WARNING continued

- The appliance is not intended for use by persons (including children) with reduced physical, sensory, or mental capabilities, or lack of experience and knowledge, unless they have been given supervision or instruction concerning use of the appliance by a person responsible for their safety.
- Do not splash, pour, or spray water directly onto or into the appliance. This might cause short circuit, electric shock, corrosion, or failure.
- Children should be supervised to ensure that they do not play with the appliance.
- Do not climb, stand, or hang on the appliance or drawers or allow children or animals to do so. Do not climb into the appliance or allow children or animals to do so. Death or serious injury could occur or the appliance could be damaged.
- Open and close the door with care. Door opened too quickly or forcefully may cause injury or damage to the appliance or surrounding equipment.
- Be careful not to pinch fingers when opening and closing the door. Be careful when opening and closing the door when children are in the area.
- Do not use combustible spray or place volatile or flammable substances in or near the appliance. They might catch fire.
- Keep the area around the appliance clean. Dirt, dust, or insects in the appliance could cause harm to individuals or damage to the appliance.

NOTICE

- Follow the water supply, drain connection, and maintenance instructions in the instruction manual carefully to reduce the risk of costly water damage.
- In areas where water damage is a concern, install in a contained area with a floor drain.

NOTICE continued

- Install the appliance in a location that stays above freezing. Normal operating ambient temperature must be within 45°F to 100°F (7°C to 38°C).
- If using the optional drain pump (HS-5061), test its operation every time the appliance is cleaned and sanitized. See "IV.B. Optional Drain Pump HS-5061" for details. If the optional drain pump is not operating properly, water could back up and overflow, leading to costly water damage.
- To help ensure that the ice storage bin drain remains clear, follow the Ice Storage Bin Drain instructions in the instruction manual once every 3 months or as often as necessary for conditions. If the ice storage bin drain becomes clogged, water could build up in the bin and overflow, leading to costly water damage.
- Do not leave the appliance on during extended periods of non-use, extended absences, or in sub-freezing temperatures. To properly prepare the appliance for these occasions, follow the instructions in "V. Preparing the Appliance for Periods of Non-Use."
- If water collects in the bin and will not drain, turn off the appliance and close the water supply line shut-off valve.
- If water seeps from the base of the appliance, turn off the appliance and close the water supply line shut-off valve. Failure to do so could lead to costly water damage.
- Do not place objects on top of the appliance.
- The ice storage bin is for ice use only. Do not store anything else in the ice storage bin.
- Protect the floor when moving the appliance to prevent damage to the floor.
- Do not allow the appliance to bear any outside weight.

I. Construction and Water/Refrigeration Circuit Diagram

A. Construction

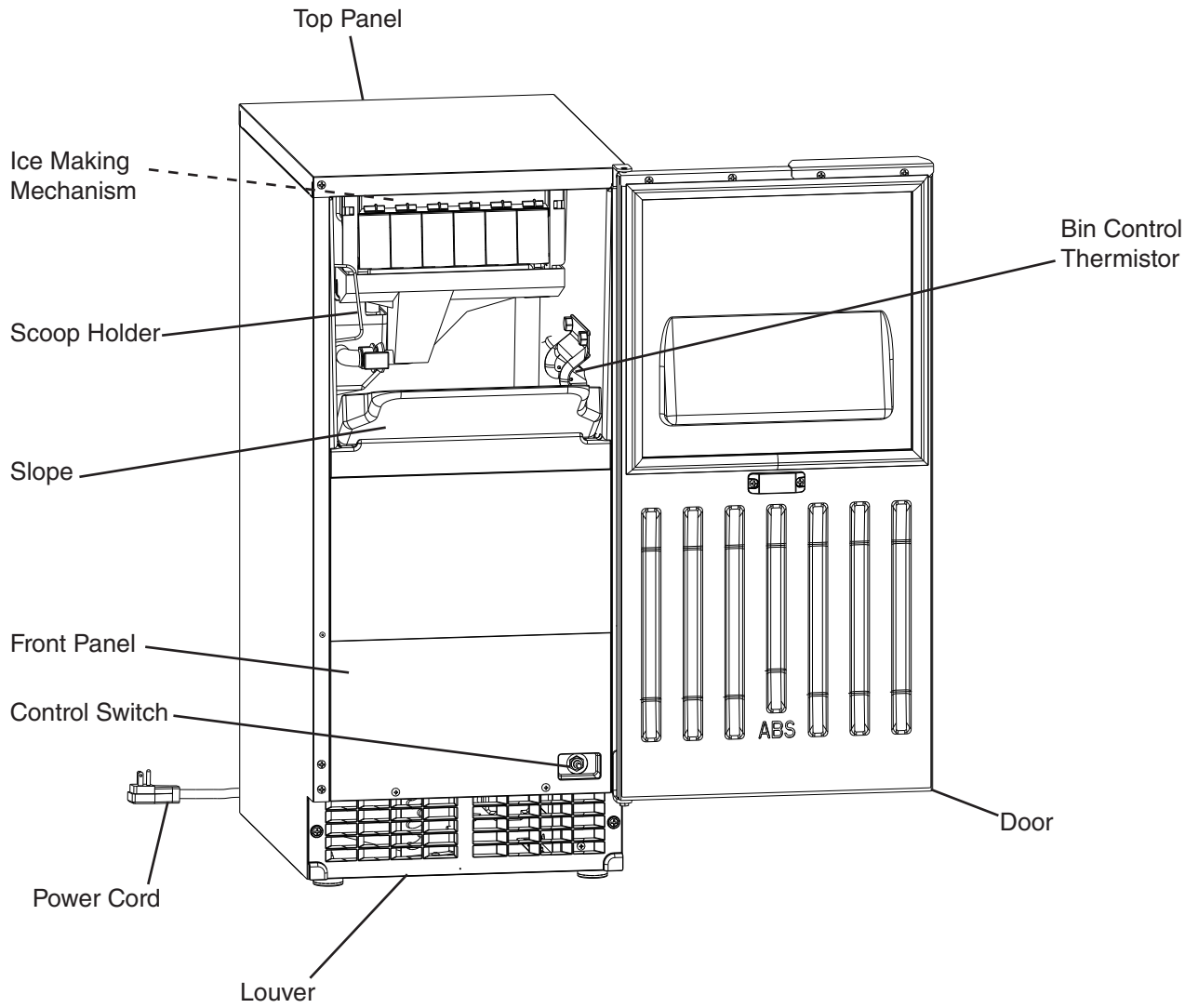

B. Water/Refrigeration Circuit Diagram

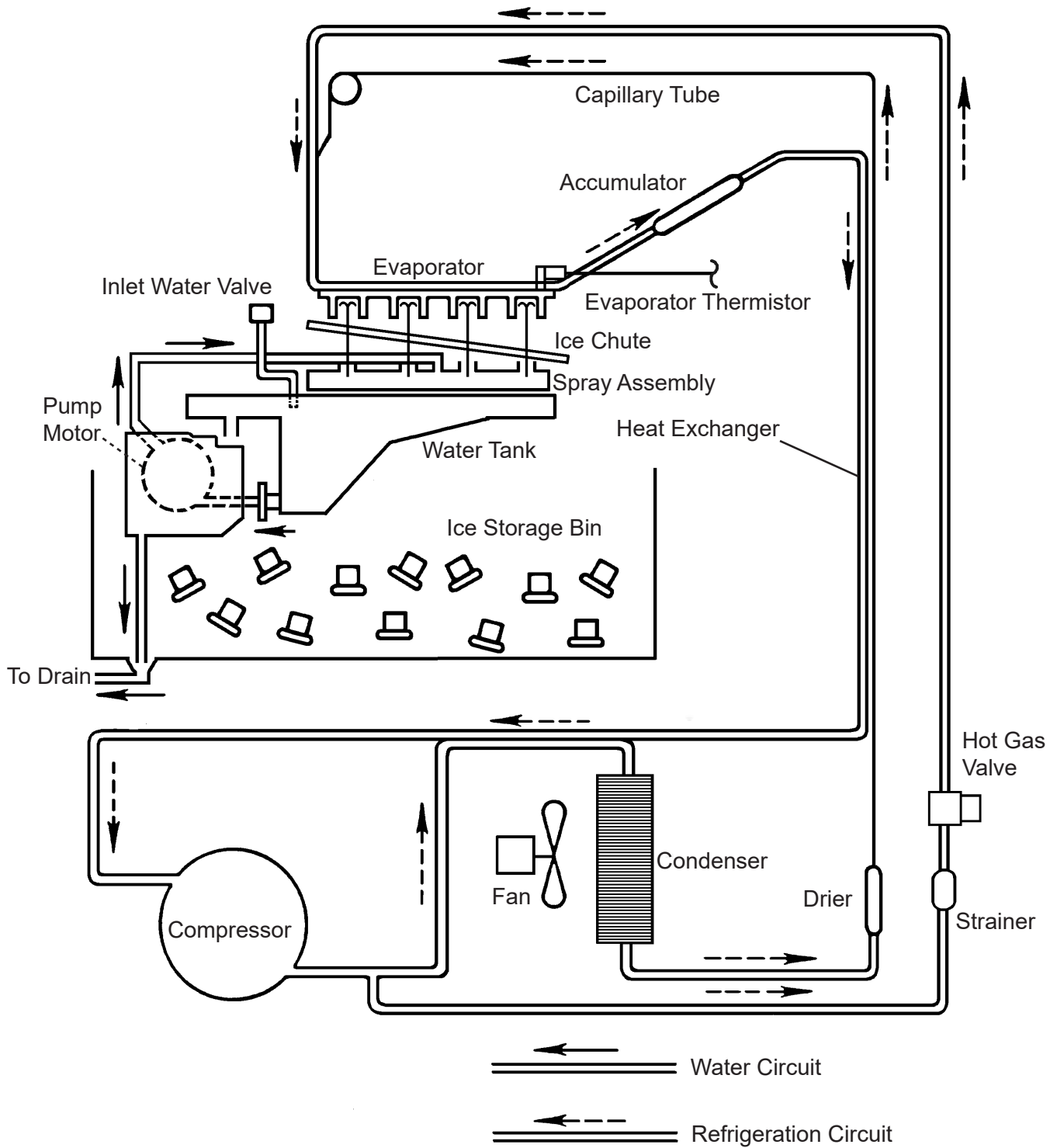

II. Sequence of Operation

A. Sequence of Operation Flow Chart

1. Icemaker Flow Chart

AM-50BAK Series Icemaker Sequence Flow Chart

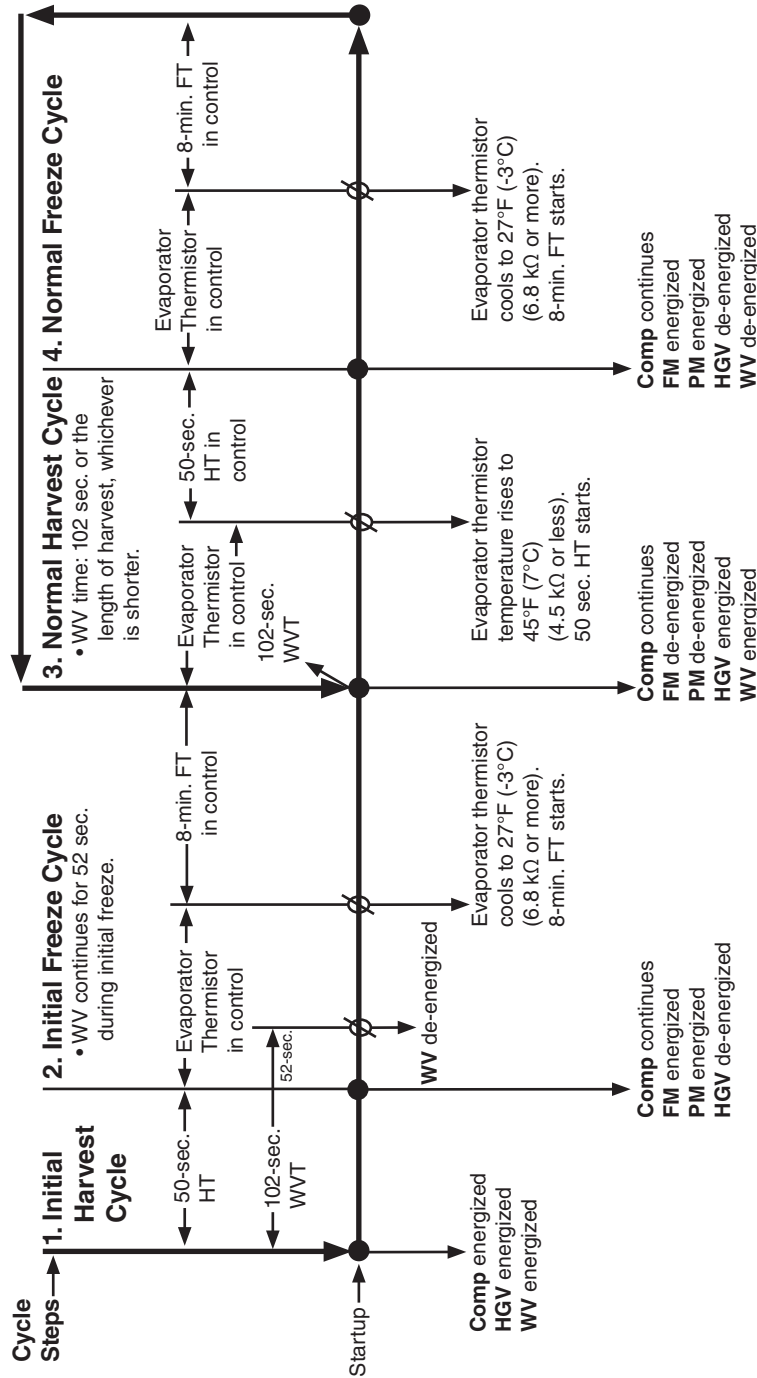

Legend:

Comp	—compressor
DP	—drain pump (optional)
FM	—fan motor
FT	—freeze timer
FTT	—freeze termination timer
HGV	—hot gas valve
HT	—harvest timer
PM	—pump motor
WV	—inlet water valve
WVT	—inlet water valve timer

2. Bin Control Shutdown Flow Chart

AM-50BAK Series Thermistor Bin Control Shutdown Sequence Flow Chart

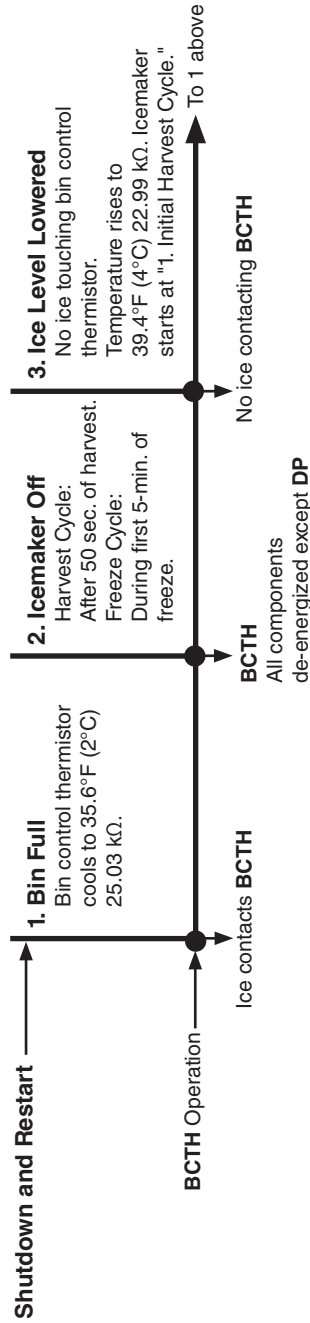

Components Energized when the Control Switch is in the "WASH" Position
The "WASH" position on the control switch is used when cleaning and sanitizing the icemaker. When in the "WASH" position, power is supplied to the pump motor and fan motor. The cleaner and sanitizer flow over the evaporator plate assembly.

III. Service Diagnosis, Refrigeration Circuit Service, and Component Service

A. Safety Precautions When Servicing | Précautions à prendre lors de l'entretien

1. English



R-290 Class A3 Flammable Refrigerant Used

⚠ DANGER

Risk of Fire or Explosion. Flammable Refrigerant Used.

- Be sure to follow all Important Safety Information located at the beginning of this manual and in this section.
- The appliance should be diagnosed and repaired only by qualified service personnel to reduce the risk of death, electric shock, serious injury, or fire.
- Servicing shall be done by trained service personnel with certified competence in handling flammable refrigerants to minimize the risk of possible ignition due to incorrect parts or improper service.
- Follow handling instructions carefully in compliance with national regulations.
- Do not use mechanical devices or other means to accelerate the defrosting process or to clean, other than those recommended by the manufacturer.
- Be aware that refrigerants may not contain an odor.
- Do not puncture refrigerant tubing. Risk of fire or explosion due to puncture of refrigerant tubing; follow handling instructions carefully.
- Component parts shall be replaced with like components. So as to minimize the risk of possible ignition due to incorrect parts.
- Do not place any potential ignition sources in or near the appliance.
- Prior to beginning work on systems containing flammable refrigerants, safety checks are necessary to ensure that the risk of ignition is minimized.
- All maintenance staff and others working in the local area shall be instructed on the nature of work being carried out. Work in confined spaces shall be avoided.
- Work shall be undertaken under a controlled procedure so as to minimize the risk of a flammable gas or vapor being present while the work is being performed.
- The area shall be checked with an appropriate refrigerant detector prior to and during work, to ensure the technician is aware of potentially toxic or flammable atmospheres.
- Ensure that the leak detection equipment being used is suitable for use with all applicable refrigerants, i.e., nonsparking, adequately sealed, or intrinsically safe.
NOTE: The use of silicone sealant can inhibit the effectiveness of some types of leak detection equipment.
- Under no circumstances shall potential sources of ignition be used in the searching for or detection of refrigerant leaks. A halide torch (or any other detector using a naked flame) shall not be used.

⚠ DANGER continued

- The following leak detection methods are deemed acceptable for all refrigerant systems:
 - Electronic leak detectors may be used to detect refrigerant leaks but, in the case of flammable refrigerants, the sensitivity might not be adequate, or might need recalibration. (Detection equipment shall be calibrated in a refrigerant-free area.) Ensure that the detector is not a potential source of ignition and is suitable for the refrigerant used. Leak detection equipment shall be set at a percentage of the LFL of the refrigerant and shall be calibrated to the refrigerant employed, and the appropriate percentage of gas (25% maximum) is confirmed.
 - Leak detection fluids are also suitable for use with most refrigerants but the use of detergents containing chlorine shall be avoided as the chlorine can react with the refrigerant and corrode the copper pipe-work.
Note: Examples of leak detection fluids are:
 - bubble method
 - fluorescent method agents
- If any hot work is to be conducted on the refrigerating equipment or any associated parts, appropriate fire extinguishing equipment shall be available on hand. A dry chemical or CO₂ fire extinguisher should be adjacent to the charging area. You must have a Class B chemical fire extinguisher available at all times.
- No person carrying out work in relation to a refrigerating system which involves exposing any pipe work shall use any sources of ignition in such a manner that it may lead to the risk of fire or explosion. All possible ignition sources, including cigarette smoking, should be kept sufficiently far away from the site of installation, repairing, removing, and disposal, during which refrigerant can possibly be released to the surrounding space. Prior to work taking place, the area around the equipment shall be surveyed to make sure that there are no flammable hazards or ignition risks. “No Smoking” signs shall be displayed.
- Ensure that the area is in the open or that it is adequately ventilated before breaking into the system or conducting any hot work. A degree of ventilation shall continue during the period that the work is carried out. The ventilation should safely disperse any released refrigerant and preferably expel it externally into the atmosphere.
- When breaking into the refrigerant circuit to make repairs – or for any other purpose – conventional procedures shall be used. However, for flammable refrigerants it is important that best practice be followed, since flammability is a consideration. The following procedure shall be adhered to:
 - safely remove refrigerant following local and national regulations
 - purge the circuit with inert gas
 - evacuate (optional for A2L)
 - purge with inert gas (optional for A2L)
 - open the circuit by cutting or brazing
- If a leak is suspected, all naked flames shall be removed/extinguished.
- If a leakage of refrigerant is found which requires brazing, all of the refrigerant shall be recovered from the system, or isolated (by means of shut off valves) in a part of the system remote from the leak.

⚠ DANGER continued

- When removing refrigerant from a system, either for servicing or decommissioning, it is recommended good practice that all refrigerants are removed safely.
- When transferring refrigerant into cylinders, ensure that only appropriate refrigerant recovery cylinders are employed. Ensure that the correct number of cylinders for holding the total system charge is available. All cylinders to be used are designated for the recovered refrigerant and labeled for that refrigerant (i.e., special cylinders for the recovery of refrigerant). Cylinders shall be complete with pressure-relief valve and associated shut-off valves in good working order. Empty recovery cylinders are evacuated and, if possible, cooled before recovery occurs.
- The recovery equipment shall be in good working order with a set of instructions concerning the equipment that is at hand and shall be suitable for the recovery of all appropriate refrigerants including, when applicable, flammable refrigerants. In addition, a set of calibrated weighing scales shall be available and in good working order. Hoses shall be complete with leak-free disconnect couplings and in good condition. Before using the recovery machine, check that it is in satisfactory working order, has been properly maintained and that any associated electrical components are sealed to prevent ignition in the event of a refrigerant release. Consult manufacturer if in doubt.
- The recovered refrigerant shall be returned to the refrigerant supplier in the correct recovery cylinder, and the relevant waste transfer note arranged. Do not mix refrigerants in recovery units and especially not in cylinders.
- If compressors or compressor oils are to be removed, ensure that they have been evacuated to an acceptable level to make certain that flammable refrigerant does not remain within the lubricant. The evacuation process shall be carried out prior to returning the compressor to the suppliers. Only electric heating to the compressor body shall be employed to accelerate this process. When oil is drained from a system, it shall be carried out safely.
- In addition to conventional charging procedures, the following requirements shall be followed:
 - Ensure that contamination of different refrigerants does not occur when using charging equipment. Hoses or lines shall be as short as possible to minimize the amount of refrigerant contained in them.
 - Cylinders shall be kept in an appropriate position according to the instructions.
 - Ensure that the refrigerating system is earthed (grounded) prior to charging the system with refrigerant.
 - Label the system when charging is complete (if not already).
 - Extreme care shall be taken not to overfill the refrigerating system.
- Prior to recharging the system, it shall be pressure-tested with the appropriate purging gas. The system shall be leak-tested on completion of charging but prior to commissioning. A follow up leak test shall be carried out prior to leaving the site.

⚠ DANGER continued

- Repair and maintenance to electrical components shall include initial safety checks and component inspection procedures. If a fault exists that could compromise safety, then no electrical supply shall be connected to the circuit until it is satisfactorily dealt with. If the fault cannot be corrected immediately but it is necessary to continue operation, an adequate temporary solution shall be used. This shall be reported to the owner of the equipment, so all parties are advised.
- Confirm that capacitors are discharged: this shall be done in a safe manner to avoid possibility of sparking.
- Confirm that no live electrical components and wiring are exposed while charging, recovering, or purging the system.
- Confirm that there is continuity of earth bonding (grounding).
- During repairs to sealed components, all electrical supplies shall be disconnected from the equipment being worked upon prior to any removal of sealed covers, etc. If it is absolutely necessary to have an electrical supply to equipment during servicing, then a permanently operating form of leak detection shall be located at the most critical point to warn of a potentially hazardous situation.
- Where electrical components are being changed, they shall be fit for the purpose and to the correct specification. At all times, Hoshizaki America's maintenance and service guidelines shall be followed. If in doubt, consult Hoshizaki America's Technical Support department for assistance.
- Confirm the actual refrigerant charge is in accordance with the room size within which the refrigerant containing parts are installed.
- Confirm the ventilation machinery and outlets are operating adequately and are not obstructed.
- Confirm marking to the equipment continues to be visible and legible. Markings and signs that are illegible shall be corrected.
- Confirm refrigerating pipe or components are installed in a position where they are unlikely to be exposed to any substance which may corrode refrigerant containing components, unless the components are constructed of materials which are inherently resistant to being corroded or are suitably protected against being so corroded.
- Particular attention shall be paid to the following to ensure that by working on electrical components, the casing is not altered in such a way that the level of protection is affected. This shall include damage to cables, excessive number of connections, terminals not made to original specification, damage to seals, incorrect fitting of glands, etc.
- Ensure that the apparatus (control box/component) is mounted securely.
- Ensure that seals or sealing materials have not degraded to the point that they no longer serve the purpose of preventing the ingress of flammable atmospheres. Replacement parts shall be in accordance with Hoshizaki America's specifications.
- Do not apply any permanent inductive or capacitance loads to the circuit without ensuring that this will not exceed the permissible voltage and current permitted for the equipment in use.

⚠ DANGER continued

- Intrinsically safe components are the only types that can be worked on while live in the presence of a flammable atmosphere. The test apparatus shall be at the correct rating.
- Replace components only with parts specified by Hoshizaki America. Other parts can result in the ignition of refrigerant in the atmosphere from a leak.
- Check that cabling will not be subject to wear, corrosion, excessive pressure, vibration, sharp edges, or any other adverse environmental effects. The check shall also take into account the effects of aging or continual vibration from sources such as compressors or fans.

2. Français



R-290 Classe A3 Réfrigérant Inflammable Utilisé

⚠ DANGER

Risque De Feu Ou D'Explosion. Fluide Frigorigène Inflammable Utilisé.

- Assurez-vous de suivre toutes les informations importantes de sécurité situées au début de ce manuel et dans cette section.
- L'appareil ne doit être diagnostiqué et réparé que par un personnel qualifié afin de prévenir les risques de mort, d'électrocution, de blessures graves ou d'incendie.
- L'entretien doit être effectué par du personnel formé et certifié pour la manipulation de réfrigérants inflammables afin de réduire au minimum le risque d'inflammation dû à des pièces incorrectes ou à un entretien inadéquat.
- Suivez attentivement les instructions de manutention conformément aux règlements nationaux.
- Ne pas utiliser de dispositifs mécaniques ou d'autres moyens pour accélérer le processus de dégivrage ou pour nettoyer, autres que ceux recommandés par le fabricant.
- Attention, les fluides frigorigènes peuvent ne pas dégager d'odeur.
- Ne pas perforer la tubulure contenant le frigorigène. Risque de feu ou d'explosion si la tubulure contenant le frigorigène est perforée; suivre les instructions de manutention avec soin.
- Les pièces doivent être remplacées par des pièces similaires, de manière à réduire au minimum le risque d'inflammation dû à des pièces incorrectes.
- Ne placez aucune source d'inflammation potentielle dans ou près de l'appareil.
- Avant de commencer à travailler sur des systèmes contenant des réfrigérants inflammables, des contrôles de sécurité sont nécessaires pour s'assurer que le risque d'inflammation est minimisé.
- Tout le personnel d'entretien et les autres personnes travaillant dans la zone locale doivent être informés de la nature des travaux effectués. Les travaux dans des espaces confinés doivent être évités.
- Les travaux doivent être entrepris selon une procédure contrôlée afin de minimiser le risque de présence de gaz ou de vapeur inflammable pendant l'exécution des travaux.
- La zone doit être contrôlée à l'aide d'un détecteur de réfrigérant approprié avant et pendant les travaux, afin de s'assurer que le technicien est conscient de l'existence d'atmosphères potentiellement toxiques ou inflammables.
- Assurez-vous que l'équipement de détection des fuites utilisé est adapté à l'utilisation de tous les réfrigérants applicables, c'est-à-dire qu'il ne produit pas d'étincelles, qu'il est correctement scellé ou qu'il est intrinsèquement sûr. REMARQUE: L'utilisation de mastic silicone peut réduire l'efficacité de certains types d'équipements de détection des fuites.
- En aucun cas, des sources potentielles d'inflammation ne doivent être utilisées pour rechercher ou détecter des fuites de réfrigérant. Une lampe haloïde (ou tout autre détecteur utilisant une flamme nue) ne doit pas être utilisée.

⚠ DANGER Continué

- Les méthodes de détection de fuite suivantes sont considérées comme acceptables pour tous les systèmes de réfrigération:
 - Des détecteurs de fuites électroniques peuvent être utilisés pour détecter les fuites de réfrigérants, mais, dans le cas de réfrigérants inflammables, la sensibilité pourrait ne pas être adéquate ou nécessiter un réétalonnage. (L'équipement de détection doit être étalonné dans une zone sans réfrigérant.) Assurez-vous que le détecteur n'est pas une source potentielle d'inflammation et qu'il est adapté au réfrigérant utilisé. L'équipement de détection des fuites doit être réglé sur un pourcentage de la LII du réfrigérant et doit être étalonné en fonction du réfrigérant utilisé, et le pourcentage approprié de gaz (25% au maximum) est confirmé.
 - Les liquides de détection des fuites conviennent également à la plupart des réfrigérants, mais l'utilisation de détergents contenant du chlore doit être évitée, car le chlore peut réagir avec le réfrigérant et corroder la tuyauterie en cuivre.
Remarque : Voici quelques exemples de liquides de détection de fuites :
 - méthode des bulles
 - agents de méthode fluorescents
- Si un travail à chaud doit être effectué sur l'équipement réfrigérant ou toute partie associée, un équipement d'extinction d'incendie approprié doit être disponible. Un extincteur à poudre chimique ou à CO₂ devrait être installé à proximité de la zone de chargement. Un extincteur chimique de classe B doit être disponible à tout moment.
- Il est interdit à toute personne effectuant des travaux en rapport avec un système réfrigérant qui impliquent la mise à nu d'une tuyauterie d'utiliser des sources d'inflammation de manière à entraîner un risque d'incendie ou d'explosion. Toutes les sources d'inflammation possibles, y compris la cigarette, doivent être suffisamment éloignées du site d'installation, de réparation, d'enlèvement et d'élimination, au cours desquels du réfrigérant peut éventuellement être libéré dans l'espace environnant. Avant d'entamer les travaux, la zone autour de l'équipement doit être étudiée pour s'assurer qu'il n'y a aucun risque d'inflammabilité ou d'inflammation. Des panneaux «Interdiction de fumer» doivent être affichés.
- Assurez-vous que la zone est à l'air libre ou qu'elle est correctement ventilée avant de pénétrer dans le système ou d'effectuer un travail à chaud. Un certain degré de ventilation doit être maintenu pendant la période où les travaux sont effectués. La ventilation doit permettre de disperser en toute sécurité tout réfrigérant libéré et, de préférence, de l'expulser dans l'atmosphère.
- Pour pénétrer dans le circuit du réfrigérant afin d'effectuer des réparations ou pour toute autre raison, des procédures conventionnelles doivent être utilisées. Toutefois, pour les réfrigérants inflammables, il est important de suivre les meilleures pratiques, car l'inflammabilité est un facteur à prendre en considération. La procédure suivante doit être respectée:
 - éliminer le réfrigérant en toute sécurité conformément aux réglementations locales et nationales
 - purger le circuit avec du gaz inerte
 - évacuer (en option pour A2L)
 - purger avec du gaz inerte (en option pour A2L)
 - ouvrir le circuit par coupure ou brasage

⚠ DANGER Continué

- Si une fuite est suspectée, toutes les flammes nues doivent être enlevées/éteintes.
- Si une fuite de réfrigérant nécessitant un brasage est constatée, tout le réfrigérant doit être récupéré dans le système ou isolé (au moyen de vannes d'arrêt) dans une partie du système éloignée de la fuite.
- Lors de l'élimination du réfrigérant d'un système, que ce soit pour l'entretien ou la mise hors service, il est recommandé de veiller à ce que tous les réfrigérants soient éliminés en toute sécurité.
- Lors du transfert de réfrigérant dans des bouteilles, veillez à ce que seules des bouteilles de récupération de réfrigérant appropriées soient utilisées. Assurez-vous que le nombre de bouteilles nécessaires pour contenir la charge totale du système est disponible. Toutes les bouteilles à utiliser sont désignées pour le réfrigérant récupéré et étiquetées pour ce réfrigérant (c'est-à-dire des bouteilles spéciales pour la récupération du réfrigérant). Les bouteilles doivent être équipées d'une soupape de surpression et de soupapes d'arrêt associées qui sont en bon état de fonctionnement. Les bouteilles de récupération vides sont évacuées et, si possible, refroidies avant la récupération.
- L'équipement de récupération doit être en bon état de fonctionnement, accompagné d'un ensemble d'instructions concernant l'équipement disponible et doit être adapté à la récupération de tous les réfrigérants appropriés, y compris, le cas échéant, les réfrigérants inflammables. En outre, un ensemble de balances étalonnées doit être disponible et en bon état de fonctionnement. Les tuyaux doivent être complets, équipés de raccords de déconnexion sans fuite et en bon état. Avant d'utiliser la machine de récupération, vérifiez qu'elle est en bon état de fonctionnement, qu'elle a été correctement entretenue et que tous les composants électriques associés sont scellés pour éviter toute inflammation en cas de fuite de réfrigérant. Consulter le fabricant en cas de doute.
- Le réfrigérant récupéré doit être renvoyé au fournisseur de réfrigérant dans la bouteille de récupération appropriée et le bon de transfert de déchets correspondant doit être établi. Ne mélangez pas les réfrigérants dans les unités de récupération et surtout pas dans les bouteilles.
- Si les compresseurs ou les huiles de compresseur doivent être retirés, assurez-vous qu'ils ont été évacués à un niveau acceptable afin de s'assurer qu'il ne reste pas de réfrigérant inflammable dans le lubrifiant. Le processus d'évacuation doit être effectué avant que le compresseur ne soit renvoyé aux fournisseurs. Seul le chauffage électrique du boîtier du compresseur doit être utilisé pour accélérer ce processus. Lorsque l'huile est vidangée d'un système, cette opération doit être effectuée en toute sécurité.

⚠ DANGER Continué

- En plus des procédures de charge conventionnelles, les exigences suivantes doivent être respectées :
 - S'assurer qu'aucune contamination de différents réfrigérants ne se produit lors de l'utilisation de l'équipement de charge. Les tuyaux ou conduites doivent être aussi courts que possible afin de minimiser la quantité de réfrigérant qu'ils contiennent.
 - Les bouteilles doivent être maintenues dans une position appropriée conformément aux instructions.
 - S'assurer que le système de réfrigération soit mis à la terre avant de charger le système avec du réfrigérant.
 - Étiqueter le système lorsque la charge est terminée (si cela n'a pas déjà été fait).
 - Il faut veiller à ne pas trop remplir le système de réfrigération.
- Avant de recharger le système, celui-ci doit être testé sous pression avec le gaz de purge approprié. Le système doit être soumis à un essai de fuite à la fin de la charge, mais avant la mise en service. Un test de contrôle de fuite doit être effectué avant de quitter le site.
- La réparation et l'entretien des composants électriques incluent les contrôles de sécurité initiaux et les procédures d'inspection des composants. En cas de défaut susceptible de compromettre la sécurité, aucune alimentation électrique ne doit être connectée au circuit tant que le problème n'a pas été résolu de manière satisfaisante. Si le défaut ne peut être corrigé immédiatement mais qu'il est nécessaire de poursuivre l'exploitation, une solution temporaire adéquate doit être utilisée. Cela doit être signalé au propriétaire de l'équipement, afin que toutes les parties soient informées.
- S'assurer que les condensateurs sont déchargés : cette opération doit être effectuée en toute sécurité afin d'éviter tout risque d'étincelle.
- S'assurer qu'aucun composant ou câblage électrique sous tension n'est exposé lors de la charge, de la récupération ou de la purge du système.
- S'assurer de la continuité de la mise à la terre.
- Lors des réparations de composants scellés, toutes les alimentations électriques doivent être déconnectées de l'équipement sur lequel on travaille avant tout retrait des couvercles scellés, etc. Si l'alimentation électrique de l'équipement est absolument nécessaire pendant l'entretien, un dispositif de détection des fuites fonctionnant en permanence doit être placé au point le plus critique afin de signaler en cas de situation potentiellement dangereuse.
- Lorsque des composants électriques sont remplacés, ils doivent être adaptés à l'usage prévu et répondre aux spécifications correctes. Les directives de maintenance et d'entretien de Hoshizaki America doivent être respectées à tout moment. En cas de doute, consulter le service d'assistance technique de Hoshizaki America pour obtenir de l'aide.
- S'assurer que la charge réelle de réfrigérant est conforme à la taille de la pièce dans laquelle les pièces contenant du réfrigérant sont installées.
- S'assurer que les dispositifs et les sorties de ventilation fonctionnent correctement et ne sont pas obstrués.

⚠ DANGER Continué

- S'assurer que le marquage de l'équipement est toujours visible et lisible. Les indications et les panneaux illisibles doivent être corrigés.
- S'assurer que les tuyaux ou les composants de réfrigération sont installés dans un endroit où ils ne risquent pas d'être exposés à une substance susceptible de corroder les composants contenant du réfrigérant, à moins que les composants ne soient construits avec des matériaux intrinsèquement résistants à la corrosion ou qu'ils ne soient protégés de manière appropriée contre la corrosion.
- Une attention particulière doit être accordée aux points suivants afin de s'assurer qu'en travaillant sur les composants électriques, le boîtier n'est pas altéré de manière à ce que le niveau de protection soit affecté. Il s'agit notamment des dommages causés aux câbles, du nombre excessif de connexions, des terminaux non conformes aux spécifications d'origine, des dommages causés aux joints et du montage incorrect des presse-étoupes, etc.
- S'assurer que l'appareil (boîtier de commande/composant) est solidement fixé.
- S'assurer que les joints ou les matériaux d'étanchéité ne sont pas dégradés au point de ne plus pouvoir empêcher la pénétration d'atmosphères inflammables. Les pièces de rechange doivent être conformes aux spécifications de Hoshizaki America.
- N'appliquez aucune charge inductive ou capacitive permanente au circuit sans vous assurer que celle-ci ne dépassera pas la tension et le courant autorisés pour l'équipement utilisé.
- Les composants à sécurité intrinsèque sont les seuls types de composants sur lesquels il est possible de travailler sous tension en présence d'une atmosphère inflammable. L'appareil d'essai doit être adapté à la puissance requise.
- Ne remplacer les composants que par des pièces spécifiées par Hoshizaki America. D'autres pièces peuvent entraîner l'inflammation du réfrigérant dans l'atmosphère à la suite d'une fuite.
- Vérifier que le câblage ne sera pas soumis à l'usure, à la corrosion, à une pression excessive, à des vibrations, à des arêtes vives ou à tout autre effet environnemental négatif. Le contrôle doit également prendre en compte les effets du vieillissement ou des vibrations continues provenant de sources telles que les compresseurs ou les ventilateurs.

B. Service Diagnosis



R-290 Class A3 Flammable Refrigerant Used

⚠ DANGER

Risk of Fire or Explosion. Flammable Refrigerant Used.

- Be sure to follow all Important Safety Information located at the beginning of this manual and at the beginning of section "III.A. Safety Precautions When Servicing."
- Servicing shall be done by trained service personnel with certified competence in handling flammable refrigerants to minimize the risk of possible ignition due to incorrect parts or improper service.

Risque De Feu Ou D'Explosion. Fluide Frigorigène Inflammable Utilisé.

- Assurez-vous de suivre toutes les informations importantes de sécurité qui se trouvent au début du présent manuel et au début de la section «III.A. Précautions de sécurité lors de l'entretien.»
- L'entretien doit être effectué par du personnel formé et certifié pour la manipulation de réfrigérants inflammables afin de réduire au minimum le risque d'inflammation dû à des pièces incorrectes ou à un entretien inadéquat.

⚠ WARNING

- Risk of electric shock. Use extreme caution and exercise safe electrical practices.
- Risk of electric shock. Control switch in "OFF" position does not de-energize all loads (optional drain pump).
- Move the control switch to the "OFF" position, then unplug the appliance from the electrical outlet before servicing.
- Moving parts (e.g., fan blade) can crush and cut. Keep hands clear.
- **CHOKING HAZARD:** Ensure all components, fasteners, and thumbscrews are securely in place after the appliance is serviced. Make sure that none have fallen into the ice storage bin.
- Make sure all food zones in the appliance are clean after service.

1. Diagnostic Procedure

The diagnostic procedure is a sequence check that allows you to diagnose the electrical system and components. Before proceeding, check for correct installation, proper voltage per nameplate, and adequate water supply.

Note: • When checking high-voltage (115VAC), always choose a white (W) neutral wire to establish a good neutral connection.

- When checking low-voltage (24VAC), always choose a light blue (LBU) neutral wire to establish a good neutral connection.
- When checking component voltage from CB, pull CB connectors out slightly to allow room for multimeter test leads contact.
- Optional drain pump (HS-5061) has 115VAC power supply as soon as the appliance is plugged into the electrical outlet.

1) Access the control box and move the control switch to the "OFF" position.

2) Clear any ice from the bin control thermistor.

3) **Power On/Initial Harvest Cycle.** Move the control switch to the "ICE" position.

THCB green LED 1 "POWER" turns on. If BCTH is at or above 39.2°F (4°C), THCB green LED 2 turns on and THCB X1 relay energizes. 115VAC supplied to CT and MCB. MCB LEDs 1 (green), 3 (green), and 4 (orange) turn on briefly then turn off. Then green LED 1 starts flashing, green LED 3 turns on and Comp, HGV, and WV energize. Initial harvest cycle starts. 50-sec. HT and 102-sec. WVT start.

Note: 24VAC to CB is confirmed with a flashing LED 1.

a) **Power On Diagnosis:** Confirm THCB green LED 1 "POWER" and green LED 2 "RELAY" are on and MCB green LED 1 (power) is flashing. If not, confirm appliance is plugged into electrical outlet. If optional drain pump HS-5061 is installed, confirm the water level in the drain pump reservoir is not high enough to close the drain pump safety switch. When the water level lowers enough to open the drain pump upper float switch, power is restored to the icemaker. The pump motor remains energized as long as the drain pump lower float switch is closed. If optional drain pump is not installed, check that jumper connection is good.

Control Switch: Check for 115VAC at control switch #2 (BR) to neutral (W) then at control switch #1 (BK) to neutral (W). If 115VAC is present at #2 (BR) to neutral (W) and not at #1 (BK) to neutral (W), replace control switch.

Bin Control Thermistor and Thermistor Control Board: If 115VAC is present at control switch #1 (BK) to neutral (W) and THCB green "POWER" LED 1 is not on, check wiring from control switch to THCB. If wiring is good, replace THCB. If THCB green "POWER" LED 1 is on and THCB green "RELAY" LED 2 is not on, remove BCTH wires from THCB K2 connectors and check BCTH continuity. See "III.B.3. Bin Control Thermistor Check." Replace as needed. If BCTH is good, reconnect BCTH wires to THCB K2. Next, check that MCB LED 1 is flashing. If MCB LED 1 is not flashing, check THCB X1 (BK) to neutral (W) for 115VAC. If 115VAC is present, check for 115VAC at THCB X1 (BR) to neutral (W). If 115VAC is present at THCB X1 (BK) and not at THCB X1 (BR), check for 115VAC at THCB K1 1 (DBU). If 115VAC is present at THCB K1 1 (DBU) and 115VAC is not present at THCB X1 (BR) (THCB LED 2 not on), replace THCB. If 115VAC is present at THCB X1 (BR) not present at THCB K1 1 (DBU), see "Control Transformer" and "Main Control Board" below.

Control Transformer: If 115VAC is present on THCB X1 (BR) and MCB LED 1 is not flashing, check for 24VAC secondary voltage at CT red (R) wire to CT light blue (LBU) wire. If 24VAC is not present, check low-voltage wiring. If low-voltage wiring is good, disconnect power and check CT windings. If open, replace CT.

Main Control Board: If 24VAC is present at MCB and MCB green LED 1 is not flashing, replace MCB. If MCB LED 1 is flashing and THCB LED 2 is not on, check MCB A1 (DBU) to neutral (W). If 115VAC is not present, replace MCB. If 115VAC is present at MCB A1 (DBU), check K1 1 (DBU). If 115VAC is present and LED 2 is not on, replace THCB.

- b) **Comp Diagnosis:** With MCB green LED 1 flashing, if Comp does not energize, check for 115VAC at control switch #4 (BR) to neutral (W) then at control switch #5 (R) to neutral (W). If 115VAC is present at #4 (BR) to neutral (W) and not at #5 (R) to neutral (W), replace control switch. If 115VAC is present at #5 (R) to neutral (W), check PTC relay continuity. If open, replace PTC. If closed, check Comp external protector and motor winding continuity. Replace as needed.
- c) **HGV Diagnosis:** If Comp is energized and evaporator is not warming, check that HGV energizes and opens. If not, check for 115VAC at MCB C1 (BR) to neutral (W) and then at MCB B1 (P) to neutral (W). If 115VAC is not present at MCB C1 (BR) to neutral (W), check wiring connections from THCB. If 115VAC is present at MCB C1 (BR) to neutral (W) and not at MCB B1 (P) to neutral (W), replace MCB. If 115VAC is present at MCB B1 (P) wire to neutral (W), check HGV coil continuity. Replace as needed.
- d) **WV (LED 3) Diagnosis:** Confirm MCB green LED 3 is on. If not, replace CB. If MCB green LED 3 is on, check that water enters the water tank. If not, check that the water supply line shut-off valve is open and screens or external filters are clear. Check for 115VAC at MCB C2 (BR) to neutral (W) and MCB A2 (O) wire to neutral (W) wire. If 115VAC is not present at MCB C2 (BR) to neutral (W), check wiring from THCB. If 115VAC is present at MCB C2 (BR) to neutral (W) wire and not at CB A2 (O) to neutral (W), replace MCB. If 115VAC is present and WV does not energize, check WV coil continuity. If open, replace WV.
- e) **Initial Harvest Cycle Termination Diagnosis:** 50-sec. HT terminates and freeze cycle starts. HGV de-energizes. If not, replace MCB. Comp continues. WV continues an additional 52 sec. into initial freeze cycle.

4) **Initial Freeze Cycle – MCB LED 1 and LED 3 continue and LED 2 turns on.**

Comp and 102-sec. WVT (WV continues another 52 sec. in freeze cycle) continue. FM and PM energize. HGV de-energizes. When 102-sec. WVT terminates, MCB LED 3 turns off and WV de-energizes. MCB monitors the cooling of the evaporator via the thermistor located on the evaporator for freeze termination. When the evaporator thermistor reaches 27°F (-3°C), MCB reads 6.8 kΩ or higher from the evaporator thermistor and starts the 8-min. FT. Evaporator temperature of 27°F (-3°C) or lower (6.8 kΩ or higher) must be maintained through-out the 8-min. FT.

- a) **Comp Diagnosis:** If Comp de-energizes, check PTC relay continuity. If open, replace PTC. If closed, check Comp external protector and motor winding continuity. Replace as needed. If Comp is energized but evaporator is not cooling, check for an inefficient Comp. See "VII.A. Specification and Performance Data."
- b) **FM Diagnosis:** If FM does not energize, check for 115VAC at MCB C1(BR) to neutral (W) and then at CB A1 (DBU) to neutral (W). If 115VAC is present at MCB C1 (BR) to neutral (W) and not at MCB A1 (DBU) to neutral (W), replace MCB. If 115VAC is present at MCB A1 (DBU) to neutral (W), check FM winding continuity and fan blade for binding.
- c) **PM Diagnosis:** If PM does not energize, check for 115VAC at MCB C1 (BR) to neutral (W) and then at CB A1 (DBU) to neutral (W). If 115VAC is present at MCB C1 (BR) to neutral (W) and not at MCB A1(DBU) to neutral (W), replace MCB. If 115VAC is present at MCB A1 (DBU) to neutral (W), check 0.375A PM fuse, replace as needed. If PM fuse is good, check PM capacitor and motor windings, replace as needed.
- d) **HGV and WV Diagnosis:** Confirm HGV and WV de-energize. If HGV is energized, check for 115VAC at MCB B1 (P) to neutral (W). If 115VAC is present after PM energizes, replace MCB. If 115VAC is not present and HGV is bypassing, replace HGV. If MCB green LED 3 does not turn off and WV does not de-energize 52 sec. after initial freeze cycle starts, check for 115VAC at MCB A2 (O) to neutral (W). If 115VAC is present 52 sec. or later after PM energizes, replace MCB. If 115VAC is not present and WV is leaking by, replace WV.
- e) **Initial Freeze Cycle Termination Diagnosis:** Freeze termination is temperature/ time terminated. Once the evaporator temperature reaches 27°F (-3°C) (6.8 KΩ or higher) 8-min. FT starts. Evaporator temperature must stay below 27°F (-3°C) (6.8 KΩ or higher) through-out the 8-min. FT. Once the 8-min. FT terminates, MCB checks evaporator thermistor for 6.8 KΩ or higher. If 6.8 KΩ or higher value is met at the end of the 8-min. FT, harvest cycle starts. FM and PM de-energize and HGV and WV energize. If not, check that evaporator thermistor is properly mounted. Next, remove the evaporator thermistor connections to MCB and check the thermistor KΩ. See "III.B.4. Evaporator Thermistor Check." If evaporator temperature is below 27°F (-3°C) (6.8 KΩ or higher) for more than 8 min. and freeze does not terminate, replace MCB.

- 5) **Normal Harvest Cycle – LED 1 is flashing, Green LED 3 is on, and Green LED 2 turns off.** Comp continues. HGV and WV energize. FM and PM de-energize. 50-sec. HT and 102-sec. WV timer starts. MCB monitors the warming of the evaporator via the evaporator thermistor. When the evaporator thermistor reaches 47°F (7°C), MCB reads 4.5 kΩ from the evaporator thermistor and starts 50-sec. HT. WV is energized during harvest for a maximum of 102 sec. or the length of harvest, whichever is shorter.
- Note: Appliance continues to cycle until BCTH is satisfied or power is turned off.
The appliance always restarts at the initial harvest cycle.
- a) **Comp Diagnosis:** Check that evaporator is warming. If not, confirm Comp is energized. If not, check for 115VAC at PTC and check PTC relay continuity. If open, replace PTC. If closed, check Comp external protector and motor winding continuity. Replace as needed.
- b) **HGV Diagnosis:** If Comp is energized and evaporator is not warming, check that HGV energizes and opens. If not, check for 115VAC at MCB C1 (BR) to neutral (W) and CB B1 (P) to neutral (W). If 115VAC is present at CB C1 (BR) to neutral (W) and not at MCB B1 (P) to neutral (W), replace MCB. If 115VAC is not present at MCB C1 (BR) to neutral (W), check wiring connections from THCB. If 115VAC is present, check HGV coil continuity. Replace as needed.
- c) **WV Diagnosis:** Confirm MCB green LED 3 is on. If not, replace MCB. If MCB green LED 3 is on, check that water enters the water tank. If not, check that the water supply line shut-off valve is open and screens or external filters are clear. Check for 115VAC at MCB C2 (BR) to neutral (W) and MCB A2 (O) to neutral (W). If 115VAC is not present at MCB C2 (BR) to neutral (W), check wiring from THCB. If 115VAC is present at MCB C2 (BR) to neutral (W) and not at MCB A2 (O) to neutral (W), replace MCB. If 115VAC is present and WV does not energize, check WV coil continuity. If open, replace WV.
- d) **FM and PM Diagnosis:** If FM and PM continue after green LED 2 turns off, replace MCB.
- e) **Normal Harvest Cycle Termination Diagnosis:** Normal harvest termination is a temperature/time termination. Evaporator temperature reaches 45°F (7°C) (4.5 kΩ or less) 50-sec. HT starts. For evaporator thermistor check, see "III.B.4. Evaporator Thermistor Check." If evaporator is warming, evaporator thermistor reading is within spec, and harvest does not terminate, replace MCB.
- 6) **Normal Freeze Cycle – LED 1 is flashing and LED 2 is on.** Comp continues. FM and PM energize. HGV and WV de-energize. MCB monitors the cooling of the evaporator via the thermistor located on the evaporator for freeze termination. When the evaporator thermistor reaches 27°F (-3°C), MCB reads 6.8 kΩ or higher from the evaporator thermistor and starts the 8-min. FT. 27°F (-3°C) or lower (6.8 kΩ or higher) must be maintained the entire 8 min.
- a) **Comp Diagnosis:** If Comp de-energizes, check PTC relay continuity. If open, replace PTC. If closed, check Comp external protector and motor winding continuity. Replace as needed. If Comp is energized but evaporator is not cooling, check for an inefficient Comp. See "VII.A. Specification and Performance Data."

- b) **FM Diagnosis:** If FM does not energize, check for 115VAC at MCB C1 (BR) to neutral (W) and at MCB A1 (DBU) to neutral (W). If 115VAC is present at MCB C1 (BR) to neutral (W) and not at MCB A1 (DBU) to neutral (W), replace MCB. If 115VAC is present at MCB A1 (DBU) to neutral (W), check FM winding continuity, fan blade for binding.
- c) **PM Diagnosis:** If PM does not energize, check for 115VAC at CB C1 (BR) to neutral (W) and at CB A1 (DBU) to neutral (W). If 115VAC is present at MCB C1 (BR) to neutral (W) and not at MCB A1 (DBU) to neutral (W), replace MCB. If 115VAC is present at MCB A1 (DBU) to neutral (W), check PM fuse. Replace as needed. If PM fuse is good, check PM motor winding continuity, impeller for binding, and PM capacitor.
- d) **HGV and WV Diagnosis:** Confirm HGV and WV de-energize. If HGV is energized, check for 115VAC at MCB B1 (P) to neutral (W). If 115VAC is present after PM energizes, replace MCB. If 115VAC is not present and HGV is bypassing, replace HGV. If LED 3 is on after LED 2 turns on, replace MCB. When LED 3 turns off, make sure WV is not leaking by. If WV is leaking by, replace WV.
- e) **Normal Freeze Cycle Termination Diagnosis:** Freeze termination is temperature/time terminated. Once the evaporator temperature reaches 27°F (-3°C) (6.8 KΩ or higher) 8-min. FT starts. Evaporator temperature must stay below 27°F (-3°C) (6.8 KΩ or higher) through-out the 8-min. FT. Once the 8-min. FT terminates, MCB checks evaporator thermistor for 6.8 KΩ or higher. If 6.8 KΩ or higher value is met at the end of the 8-min. FT, harvest cycle starts. FM and PM de-energize and HGV and WV energize. If not, check that evaporator thermistor is properly mounted. Next, remove the evaporator thermistor connections to MCB and check the evaporator thermistor KΩ. See "III.B.4. Evaporator Thermistor Check." If evaporator temperature is below 27°F (-3°C) (6.8 KΩ or higher) for more than 8 min. and freeze does not terminate, replace MCB.
- 7) **Shutdown - Bin control thermistor:** When the appliance is running, hold ice in contact with the thermistor bulb. THCB X1 relay switch opens within 30 to 60 sec., shutting down the appliance. No adjustment available. If THCB X1 relay switch does not shutdown icemaker, check BCTH KΩ reading. See "III.B.3. Bin Control Thermistor Check." If the bin control thermistor is good and icemaker does not shutdown, replace THCB.

Legend: **BCTH**—bin control thermistor; **Comp**—compressor; **FM**—fan motor; **FT**—freeze timer; **FTT**—freeze termination timer; **HGV**—hot gas valve; **HT**—harvest timer; **MCB**—main control board; **PM**—pump motor; **BCTH**— bin control thermistor; **THCB**—thermistor control board; **WV**—inlet water valve; **WVT**—inlet water valve timer

2. Main Control Board Check

The harvest and freeze cycles are controlled by the evaporator thermistor and MCB. Initial harvest is a time-termination only (50 sec.). For initial freeze, normal harvest, and normal freeze, MCB monitors the warming or cooling of the evaporator via the thermistor located on the evaporator.

Normal Harvest: When the evaporator thermistor reaches 47°F (7°C), MCB reads 4.5 kΩ from the evaporator thermistor and turns harvest termination over to the 50-sec. harvest timer.

Initial Freeze and Normal Freeze: MCB monitors the cooling of the evaporator via the thermistor located on the evaporator. When the evaporator thermistor reaches 27°F (-3°C), MCB reads 6.8 kΩ from the evaporator thermistor and turns freeze termination over to the 3-min. freeze timer. MCB must read 27°F (-3°C) for a minimum of 3 min. otherwise, 3-min. freeze timer resets. Once 27°F (-3°C) is maintained for 3 min. 3-min. freeze timer terminates and 5-min. freeze termination timer starts.

Before replacing MCB that does not show a visible defect and that you suspect is bad, always conduct the following check procedure. This procedure will help you verify your diagnosis.

- 1) Move the control switch to the "ICE" position. MCB LED 1 turns on and flashes. If not, check for 24VAC at MCB Confirm 115VAC at MCB U (BK) to neutral MCB V (W) and at MCB C1 and C2 (BK) to neutral (W). Always choose a white (W) neutral wire to establish a good neutral connection when checking voltages.
- 2) **Initial Harvest Cycle:** Comp energized.
 - a) HGV and WV energize: Check for 115VAC at MCB A2 (V) and MCB B1 (P) to neutral (W). If 115VAC is not present, replace MCB.
- 3) **Initial Harvest Cycle Termination Check:** 50 sec. after startup, harvest cycle terminates. If not, replace MCB.
- 4) **Initial Freeze Cycle:** Comp continues.
 - a) FM and PM energize, HGV de-energizes: 50 sec. after Comp energizes, check for 115VAC at MCB A1 (DBU) to neutral (W). If 115VAC is not present, check for 115VAC at MCB B1 (P). If 115VAC is present on MCB B1 (P) and not at MCB A1 (DBU), HGV is still energized and MCB is still in harvest cycle. Replace MCB.
 - b) WV: WV continues for 52 sec. If not, replace MCB. 52 sec. after PM energizes, WV de-energizes, if not, replace MCB.
- 5) **Initial Freeze Cycle Termination Check:** Comp continues.
 - a) Has evaporator thermistor reached 27°F (-3°C)? If evaporator temperature below 27°F (-3°C) for 3min. MCB starts 3-min. freeze timer. 3 min. freeze timer terminates, MCB starts 5-min. freeze termination timer. If 27°F (-3°C) or lower is maintained longer than 8 min. and MCB is still in freeze, replace MCB.

6) **Normal Harvest Cycle:** Comp continues.

a) WV energizes: Check for 115VAC at MCB A2 (O) to neutral (W). If 115VAC is not present, check for 115VAC at MCB A1 (DBU) to neutral (W). If 115VAC is present on MCB A1 (DBU) and not at MCB A2 (O), MCB is still in freeze cycle. If 115VAC is present on MCB A2 (O) WV energizes.

b) HGV energizes: Check for 115VAC at MCB A1 (LBU) and MCB B1 (P) to neutral (W). If 115VAC is present at MCB A1 (LBU) and not at MCB B1 (P), MCB is still in freeze. If temperature and time have been achieved, replace MCB.

7) **Normal Harvest Cycle Termination:**

Has evaporator thermistor reached 47°F (7°C)? Is evaporator thermistor reading 4.5 kΩ? See "III.B.4. Evaporator Thermistor Check." Once 47°F (7°C) is reached, MCB starts 50-sec. harvest timer. 50 -sec. harvest timer terminates. If freeze cycle does not start, replace MCB.

Legend: **Comp**—compressor; **CT**—control transformer; **FM**—fan motor; **HGV**—hot gas valve; **MCB**—main control board; **PM**—pump motor; **WV**—water valve

3. Bin Control Thermistor Check

To check the bin control thermistor, follow the steps below.

NOTICE

When the ambient temperature is below 45°F (7°C), the bin control thermistor may shut down the appliance even if the ice storage bin is empty.

- 1) Move the control switch to the "OFF" position.
- 2) Unplug the appliance.
- 3) Remove the front panel and control box cover. Loosen the control box from the base and slide it out for easy access. Next, clear any ice away from BCTH.
- 4) Remove the bin control thermistor from mounting bracket.
- 5) Immerse the bin control thermistor in a glass containing ice and water for 2 or 3 min.
- 6) Disconnect the BCTH connector from the THCB and check the resistance between the bin control thermistor leads. *Normal range is 26.1 to 28.4 kΩ. If outside the normal range, replace BCTH. If within the normal range, continue to the next step.
- 7) Replace the BCTH in its correct position.
- 8) Reconnect the BCTH connector to the THCB.
- 9) Replace the control box and control box cover in their correct positions.
- 10) Replace the front panel in its correct position.
- 11) Move the control switch to the "ICE" position.
- 12) Turn on the power supply.

Legend: **BCTH**—bin control thermistor;
THCB—thermistor control board

°C	R/T	°C	R/T	°C	R/T
-16	55950	20	12090	56	3426
-15	53390	21	11630	57	3319
-14	50960	22	11200	58	3216
-13	48660	23	10780	59	3116
-12	46480	24	10380	60	3021
-11	44410	25	10000	61	2928
-10	42450	26	9632	62	2838
-9	40560	27	9281	63	2752
-8	38760	28	8944	64	2669
-7	37050	29	8622	65	2589
-6	35430	30	8313	66	2512
-5	33890	31	8015	67	2437
-4	32430	32	7729	68	2365
-3	31040	33	7455	69	2296
-2	29720	34	7192	70	2229
* -1	28470	35	6941	71	2163
0	27280	36	6699	72	2100
1	26130	37	6468	73	2039
2	25030	38	6246	74	1980
3	23990	39	6033	75	1924
4	22990	40	5828	76	1869
5	22050	41	5630	77	1816
6	21150	42	5439	78	1765
7	20290	43	5256	79	1716
8	19480	44	5080	80	1668
9	18700	45	4912	81	1621
10	17960	46	4749	82	1577
11	17240	47	4594	83	1533
12	16550	48	4444	84	1491
13	15900	49	4300	85	1451
14	15280	50	4161	86	1411
15	14680	51	4026	87	1373
16	14120	52	3897	88	1336
17	13570	53	3772	89	1300
18	13060	54	3652	90	1266
19	12560	55	3537	95	1108

4. Evaporator Thermistor Check

To check the evaporator thermistor resistance, follow the steps below.

- 1) Move the control switch to the "OFF" position.
- 2) Unplug the appliance.
- 3) Remove the control box cover.
- 4) Remove the thermistor from the evaporator.
- 5) Immerse the evaporator thermistor sensor portion in a glass containing ice and water for 2 or 3 min.
- 6) Disconnect the evaporator thermistor connector from CB and check the resistance between the evaporator thermistor leads. Normal range is 5.5 to 6.5 k Ω . If outside the normal range, replace the evaporator thermistor. If within the normal range, continue to the next step.
- 7) Replace the evaporator thermistor in its correct position. See "III.D. Component Service."
- 8) Reconnect the evaporator thermistor connector to CB.
- 9) Replace the control box cover in its correct position.
- 10) Plug the appliance back into the electrical outlet.
- 11) Move the control switch to the "ICE" position.

Legend: **CB**—control board

5. Main Control Board and Thermistor Control Board Layout

- Hoshizaki exclusive control boards are employed into the AM series appliances.
- All models are pretested and factory adjusted.

NOTICE
<ul style="list-style-type: none"> • Fragile, handle very carefully. • The control boards contain integrated circuits, which are susceptible to failure due to static discharge. It is especially important to touch the metal part of the icemaker first when handling or replacing the control board. • Do not touch the electronic devices on the control board or the back of the control board. • Do not change wiring and connections. • Do not short out power supply to test for voltage. • Always replace the whole control board assembly if it goes bad.

a) Main Control Board Layout

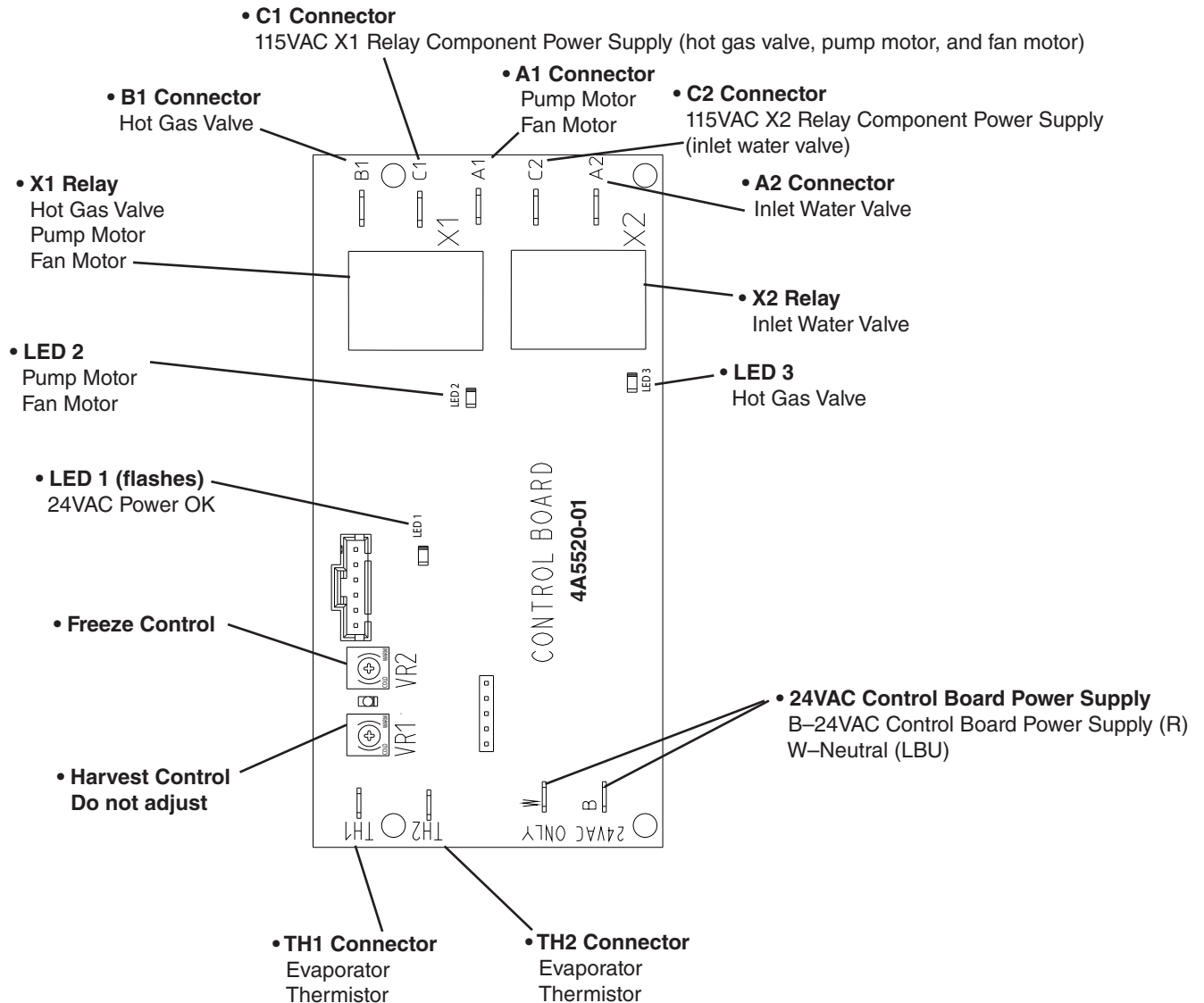

b) Thermistor Control Board Layout (bin control)

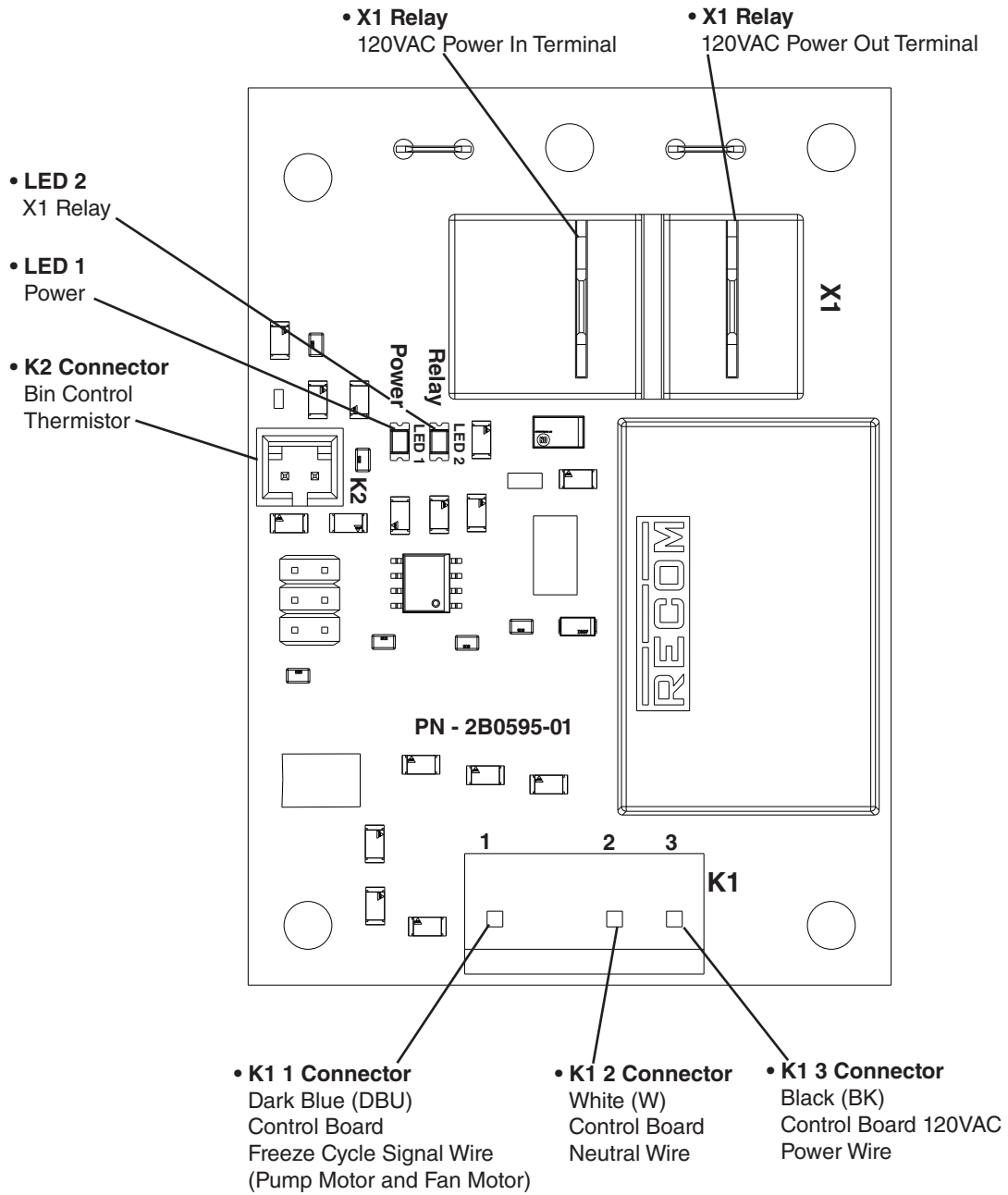

6. Main Control Board Settings and Adjustments

1) VR1 Harvest Control

VR1 harvest control is for adjustment of the harvest cycle completion temperature. Factory set, do not adjust.

NOTICE

Do not adjust VR1 harvest control. VR1 harvest control is factory set for proper operation. Adjustment outside of the factory default setting will result in freeze up and/or damage to the appliance.

- a) **Initial Harvest:** Terminated by 50 sec. harvest timer. No temperature requirement.
- b) **Normal Harvest:** Terminated by temperature (47°F (7°C)) and time (50 sec. harvest timer). Once the thermistor warms to 47°F (7°C), CB reads 4.5 kΩ from the thermistor and turns harvest termination over to the 50-sec. harvest timer.

2) VR2 Freeze Control

VR2 freeze control is for adjustment of the freeze cycle completion temperature (controls size of hole in ice cube). If adjustment to cube hole size is desired, follow the instructions below. See Fig. 1.

NOTICE

Do not adjust VR2 to the lowest temperature setting. This will result in freeze up.

- a) **Larger Hole:** Turn VR2 freeze control clockwise for a higher freeze cycle completion temperature (WARM) for shorter freeze time and ice cubes with larger diameter holes.
- b) **Smaller Hole:** Turn VR2 freeze control counterclockwise for a lower freeze cycle completion temperature (COLD) for longer freeze time and ice cubes with smaller diameter holes.

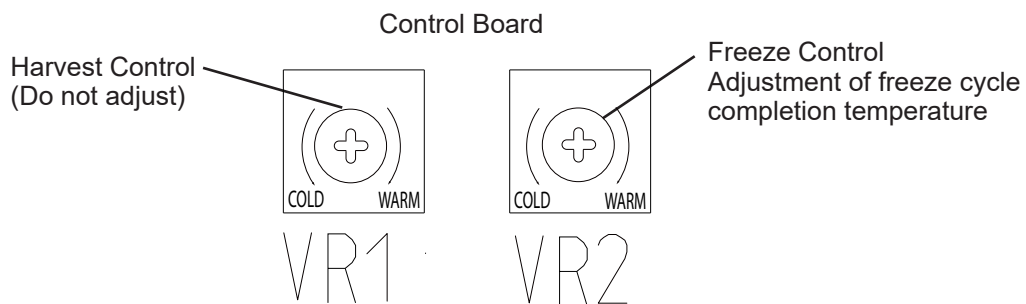

Fig. 1

7. LED Lights

a) Main Control Board LED Lights

1) LED 1 24VAC

Green LED 1 flashes to indicate proper 24VAC and continues to flash unless BCTH or THCB X1 relay are open, control switch is moved to the "OFF" position, or appliance is unplugged.

2) LED 2 Freeze

Green LED 2 (PM) turns on at freeze cycle initiation and turns off at freeze cycle termination.

3) LED 3 Harvest

Green LED 3 (WV) turns on at harvest cycle initiation and turns off after 102-sec. water valve timer terminates.

b) Thermistor Control Board LED Lights

1) LED 1 115VAC (POWER)

Green LED 1 "POWER" turns on solid to indicate proper 115VAC and continues unless the control switch is moved to the "OFF" position, or appliance is unplugged.

2) LED 2 Icemaking (X1 Relay)

Green LED 2 turns on when BCTH k Ω value is below the factory k Ω setting for icemaking. LED 2 turns off when BCTH k Ω value is above the factory k Ω setting for shutdown.

Legend: **PM**–pump motor; **BCTH**–bin control thermistor; **THCB**–thermistor control board;
WV–inlet water valve

8. Control Switch

The control switch has three positions: "OFF," "ICE," and "WASH." In the "OFF" position power is still present at the DP connector and DP (if applicable). In the "WASH" position, PM and FM energize after the 50 sec. HT terminates.

Note: When in the "WASH" position, FM also energizes.

Legend: **BCTH**–bin control thermistor; **DP**–drain pump; **HT**–harvest timer; **FM**–fan motor;
PM–pump motor; **THCB**–thermistor control board

9. Diagnostic Tables

1. No Ice Production

No Ice Production - Possible Cause	
1. Power Supply	a) Unplugged, off, blown fuse, or tripped breaker.
	b) Not within specifications.
2. Water Supply	a) Water supply off or improper water pressure.
	b) External water filters clogged.
3. Optional Drain Pump (HS-5061)	a) Safety switch open.
	b) Connector loose or disconnected.
	c) Clogged or kinked hose.
	d) Defective.
4. Control Switch	a) In "OFF" or "WASH" position.
	b) Bad contacts.
5. Bin Control Thermistor "III.B.3. Bin Control Thermistor Check"	a) Ambient temperature too cool.
	b) Thermistor out of bracket.
	c) Defective.
6. Thermistor Control Board	a) Defective.
7. Control Transformer (115VAC/24VAC)	a) Defective.
8. Main Control Board	a) Defective.
9. Compressor	a) External protector defective.
	b) PTC defective.
	c) Inefficient.
	d) Open windings.
10. Inlet Water Valve	a) Screen or orifice clogged.
	b) Coil winding open.
	c) Inlet water valve remains open longer than 52 sec. in initial freeze cycle or remains open in normal freeze cycle.
11. Hot Gas Valve	a) Closed in harvest cycle.
	b) Open in freeze cycle.
12. Evaporator Thermistor See "III.B.4. Evaporator Thermistor Check"	a) Loose, disconnected, or defective.
13. Pump Motor	a) Fuse blown.
	b) Motor winding open.
	c) Bearing worn out or locked rotor.
	d) Defective capacitor (if applicable).
14. Fan Motor	a) Motor winding open.
	b) Bearing worn out or locked rotor.

2. Freeze-Up

Defrost and clean the icemaker prior to diagnosing freeze-up. Fill out a freeze-up checklist. See the Hoshizaki America Technician's Pocket Guide or contact your local distributor for a copy of the freeze-up checklist.

Freeze-Up - Possible Cause	
Harvest Cycle	
1. Evaporator	a) Scaled up. b) Damaged.
2. Ice Chute	a) Out of position. b) Damaged.
3. Main Control Board See "III.B.6. Main Control Board Settings and Adjustments."	a) Harvest control set too short. Do not adjust. b) Freeze control set too long. c) Defective.
4. Bin Control Thermistor See "III.B.3. Bin Control Thermistor Check"	a) Defective.
5. Evaporator Thermistor See "III.B.4. Evaporator Thermistor Check"	a) Loose, disconnected, or defective.
6. Refrigerant Charge	a) Low.
7. Hot Gas Valve	a) Closed or restricted.
Freeze Cycle	
1. Evaporator	a) Scaled up. b) Damaged.
2. Spray Assembly	a) Nozzles dirty. b) Ice chute out of position.
3. Bin Control Thermistor See "III.B.3. Bin Control Thermistor Check"	a) Defective.
4. Main Control Board See "III.B.6. Main Control Board Settings and Adjustments."	a) Freeze control set incorrectly. b) Defective.
5. Evaporator Thermistor See "III.B.4. Evaporator Thermistor Check"	a) Defective.
6. Refrigerant Charge	a) Low.
7. Inlet Water Valve	a) Leaking by.
8. Pump Motor	a) RPM too slow. b) Impeller restricted or damaged. c) Defective.

3. Low Ice Production

Low Ice Production - Possible Cause	
Long Harvest Cycle	
1. Evaporator	a) Scaled up, dirty.
2. Ice Chute	a) Out of position.
	b) Damaged.
3. Refrigerant Charge	a) Low.
4. Main Control Board See "III.B.6. Main Control Board Settings and Adjustments."	a) Thermistor connection loose.
	b) Harvest control moved from factory setting.
	c) Defective.
5. Evaporator Thermistor See "III.B.4. Evaporator Thermistor Check"	a) Loose, disconnected, or defective.
6. Hot Gas Valve	a) Erratic or closed.
7. Inlet Water Valve	a) Screen or orifice clogged.
8. Compressor	a) Inefficient or off.
Long Freeze Cycle	
1. Evaporator	a) Scaled up, dirty.
2. Inlet Water Valve	a) Leaking by.
3. Hot Gas Valve	a) Erratic or open.
4. Condenser	a) Clogged.
5. Evaporator Thermistor See "III.B.4. Evaporator Thermistor Check"	a) Loose, disconnected, or defective.
6. Main Control Board See "III.B.6. Main Control Board Settings and Adjustments."	a) Freeze control set too long.
	b) Defective.
7. Refrigerant Charge	a) Low.
8. Compressor	a) Inefficient or off.
9. Pump Motor	a) RPM too slow.
	b) Impeller restricted or damaged.
	c) Defective.

C. Refrigeration Circuit Service



R-290 Class A3 Flammable Refrigerant Used

⚠ DANGER

Risk of Fire or Explosion. Flammable Refrigerant Used.

- Be sure to follow all Important Safety Information located at the beginning of this manual and at the beginning of section "III.A. Safety Precautions When Servicing."
- Servicing shall be done by trained service personnel with certified competence in handling flammable refrigerants to minimize the risk of possible ignition due to incorrect parts or improper service.
- Confirm that capacitors are discharged: this shall be done in a safe manner to avoid possibility of sparking.
- A dry chemical or CO₂ fire extinguisher should be adjacent to the charging area. You must have a Class B chemical fire extinguisher available at all times.
- When breaking into the refrigerant circuit to make repairs – or for any other purpose – conventional procedures shall be used. However, for flammable refrigerants it is important that best practice be followed, since flammability is a consideration. The following procedure shall be adhered to:
 - safely remove refrigerant following local and national regulations
 - purge the circuit with inert gas
 - evacuate (optional for A2L)
 - purge with inert gas (optional for A2L)
 - open the circuit by cutting or brazing
- Confirm that no live electrical components and wiring are exposed while charging, recovering, or purging the system.
- You must have a combustible gas leak detector in the immediate work area at all times.
- Be sure the area is clear of refrigerant vapor before brazing.
- The refrigerant charge shall be recovered into the correct recovery cylinders if venting is not allowed by local and national codes. For appliances containing flammable refrigerants, the system shall be purged with oxygen-free nitrogen to render the appliance safe for flammable refrigerants. This process might need to be repeated several times. Compressed air or oxygen shall not be used for purging refrigerant systems.

⚠ DANGER Continué

Risque De Feu Ou D'Explosion. Fluide Frigorigène Inflammable Utilisé.

- Assurez-vous de suivre toutes les informations importantes de sécurité qui se trouvent au début du présent manuel et au début de la section «III.A. Précautions de sécurité lors de l'entretien.»
- L'entretien doit être effectué par du personnel formé et certifié pour la manipulation de réfrigérants inflammables afin de réduire au minimum le risque d'inflammation dû à des pièces incorrectes ou à un entretien inadéquat.
- S'assurer que les condensateurs sont déchargés : cette opération doit être effectuée en toute sécurité afin d'éviter tout risque d'étincelle.
- Un extincteur à poudre chimique ou à CO₂ devrait être installé à proximité de la zone de chargement. Un extincteur chimique de classe B doit être disponible à tout moment.
- Pour pénétrer dans le circuit du réfrigérant afin d'effectuer des réparations ou pour toute autre raison, des procédures conventionnelles doivent être utilisées. Toutefois, pour les réfrigérants inflammables, il est important de suivre les meilleures pratiques, car l'inflammabilité est un facteur à prendre en considération. La procédure suivante doit être respectée:
 - éliminer le réfrigérant en toute sécurité conformément aux réglementations locales et nationales
 - purger le circuit avec du gaz inerte
 - évacuer (en option pour A2L)
 - purger avec du gaz inerte (en option pour A2L)
 - ouvrir le circuit par coupure ou brasage
- S'assurer qu'aucun composant ou câblage électrique sous tension n'est exposé lors de la charge, de la récupération ou de la purge du système.
- Un détecteur de fuites de gaz combustible doit se trouver à tout moment dans la zone de travail immédiate.
- Assurez-vous que la zone est exempte de vapeur de réfrigérant avant de procéder au brasage.
- La charge de réfrigérant doit être récupérée dans les bouteilles de récupération appropriées si la ventilation n'est pas autorisée par les normes locales et nationales. Pour les appareils contenant des réfrigérants inflammables, le système doit être purgé avec de l'azote sans oxygène afin de rendre l'appareil inoffensif pour les réfrigérants inflammables. Cette procédure peut être répétée plusieurs fois. L'air comprimé ou l'oxygène ne doivent pas être utilisés pour la purge des systèmes de réfrigération.

⚠ WARNING

- Wear appropriate personal protective equipment (PPE) when servicing the appliance.
- Notify all persons in the immediate area that you are working with a flammable refrigerant.
- Do not use silver alloy or copper alloy containing arsenic.

a) Refrigerant Recovery

Using proper refrigerant practices, place piercing valves toward the end (crimped area) of the high and low-side process tubes, then recover the refrigerant into an approved container or device.

- 1) Move the control switch to the "OFF" position, then unplug the appliance from the electrical outlet.

b) Brazing

- 2) Prior to brazing, purge with nitrogen gas for 2 min., flowing at a pressure of 3 to 5 PSIG.

⚠ DANGER! For appliances containing flammable refrigerants, the system shall be purged with oxygen-free nitrogen to render the appliance safe for flammable refrigerants. This process might need to be repeated several times. Compressed air or oxygen shall not be used for purging refrigerant systems.

- 3) Braze/repair/replace damaged component or fittings while purging with nitrogen gas, flowing at a pressure of 3 to 5 PSIG.

NOTICE

- Do not leave the system open for longer than 15 min. when replacing or servicing parts. The Polyol Ester (POE) oils used in R-290 applications can absorb moisture quickly. Therefore it is important to prevent moisture from entering the system when replacing or servicing parts.
- Always install a new drier every time the sealed refrigeration system is opened. Do not replace the drier until after all other repair or replacement has been made. Install the new drier with the arrow on the drier in the direction of the refrigerant flow.
- When brazing, protect the drier by using a wet cloth to prevent the drier from overheating. Do not allow the drier to exceed 250°F (121°C).

- 4) Use soap bubbles to check for leaks. Raise the pressure using nitrogen gas (190 PSIG). Do not use any refrigerant as a mixture with pressurized air for leak testing.
- 5) Once leak checking is complete, release the nitrogen gas from the system.

c) Evacuation

- 6) Attach a vacuum pump to the system. Be sure the high-side charging hose is connected to the field-installed high-side access valve.

IMPORTANT

The vacuum level and vacuum pump may be the same as those for current refrigerants. However, the rubber hose and gauge manifold to be used for evacuation and refrigerant charge should be exclusively for POE oils.

- 7) Turn on the vacuum pump, then open the high-side valve on the gauge manifold. Never allow the oil in the vacuum pump to flow backwards.
- 8) Allow the vacuum pump to pull down to a 29.9" Hg vacuum. Evacuating period depends on pump capacity.

- 9) Close the high-side valve on the gauge manifold.
- 10) Disconnect the gauge manifold hose from the vacuum pump and attach it to a refrigerant service cylinder. Remember to loosen the connection and purge the air from the hose. See the nameplate for the required refrigerant charge. Hoshizaki recommends only virgin refrigerant or reclaimed refrigerant which meets the requirements of AHRI Standard 700 (latest edition) be used.

d) Recharge

⚠ DANGER

- In addition to conventional charging procedures, the following requirements shall be followed:
 - Ensure that contamination of different refrigerants does not occur when using charging equipment. Hoses or lines shall be as short as possible to minimize the amount of refrigerant contained in them.
 - Cylinders shall be kept in an appropriate position according to the instructions.
 - Ensure that the refrigerating system is earthed (grounded) prior to charging the system with refrigerant.
 - Label the system when charging is complete (if not already).
 - Extreme care shall be taken not to overfill the refrigerating system.
 - The system shall be leak-tested on completion of charging but prior to commissioning. A follow up leak test shall be carried out prior to leaving the site.
-
- En plus des procédures de charge conventionnelles, les exigences suivantes doivent être respectées :
 - S'assurer qu'aucune contamination de différents réfrigérants ne se produit lors de l'utilisation de l'équipement de charge. Les tuyaux ou conduites doivent être aussi courts que possible afin de minimiser la quantité de réfrigérant qu'ils contiennent.
 - Les bouteilles doivent être maintenues dans une position appropriée conformément aux instructions.
 - S'assurer que le système de réfrigération soit mis à la terre avant de charger le système avec du réfrigérant.
 - Étiqueter le système lorsque la charge est terminée (si cela n'a pas déjà été fait).
 - Il faut veiller à ne pas trop remplir le système de réfrigération.
 - Avant de recharger le système, celui-ci doit être testé sous pression avec le gaz de purge approprié. Le système doit être soumis à un essai de fuite à la fin de la charge, mais avant la mise en service. Un test de contrôle de fuite doit être effectué avant de quitter le site.

- 11) R-290 can be charged in either the liquid or vapor state. Liquid charge is preferred. If refrigerant charging is done in the liquid state, place the service cylinder on the scales; **if the service cylinder is not equipped with a dip tube, invert the service cylinder, then place it on the scales.** Open the high-side valve on the gauge manifold.

- 12) Allow the system to charge with liquid until the proper charge weight is met.
- 13) Close the high-side valve on the gauge manifold. If charging is complete, skip to step 10.
- 14) If necessary, add any remaining charge to the system through the low-side.
NOTICE! To prevent compressor damage, use a throttling valve or liquid dispensing device to add the remaining liquid charge through the low-side refrigerant access valve with the compressor running. Close the refrigerant cylinder valve and let the low-side refrigerant equalize to the system, then close the low-side manifold gauge.
- 15) Pinch off (crimp down) the process tubes just below the piercing valves.
- 16) Remove the piercing valves. Cut the process tubes to remove the piercing valve holes.
- 17) Confirm there are no leaks from the pinched off process tubes, then braze the process tubes closed. **⚠ DANGER! Be sure there is no refrigerant leak before brazing.**
- 18) Use a combustible gas leak detector or soap bubbles to check for leaks again.
- 19) Place red sleeves over the process tubes.
- 20) Plug the appliance back into the electrical outlet.

D. Component Service

	R-290 Class A3 Flammable Refrigerant Used
⚠ DANGER	
<u>Risk of Fire or Explosion. Flammable Refrigerant Used.</u>	
<ul style="list-style-type: none"> • Be sure to follow all Important Safety Information located at the beginning of this manual and at the beginning of section "III.A. Safety Precautions When Servicing." • Component parts shall be replaced with like components. So as to minimize the risk of possible ignition due to incorrect parts. • This appliance should be diagnosed and repaired only by qualified service personnel to reduce the risk of death, electric shock, serious injury, or fire. • Repair and maintenance to electrical components shall include initial safety checks and component inspection procedures. If a fault exists that could compromise safety, then no electrical supply shall be connected to the circuit until it is satisfactorily dealt with. If the fault cannot be corrected immediately but it is necessary to continue operation, an adequate temporary solution shall be used. This shall be reported to the owner of the equipment, so all parties are advised. • Confirm that capacitors are discharged: this shall be done in a safe manner to avoid possibility of sparking. • Confirm that no live electrical components and wiring are exposed while charging, recovering, or purging the system. • Confirm that there is continuity of earth bonding (grounding). 	

⚠ DANGER Continué

Risque D'Incendie ou D'Explosion. Fluide Frigorigène Inflammable Utilisé.

- Assurez-vous de suivre toutes les informations importantes de sécurité qui se trouvent au début du présent manuel et au début de la section «III.A. Précautions de sécurité lors de l'entretien.»
- Les pièces doivent être remplacées par des pièces similaires, de manière à réduire au minimum le risque d'inflammation dû à des pièces incorrectes.
- Cet appareil ne doit être diagnostiqué et réparé que par un personnel qualifié afin de réduire les risques de mort, d'électrocution, de blessures graves ou d'incendie.
- La réparation et l'entretien des composants électriques incluent les contrôles de sécurité initiaux et les procédures d'inspection des composants. En cas de défaut susceptible de compromettre la sécurité, aucune alimentation électrique ne doit être connectée au circuit tant que le problème n'a pas été résolu de manière satisfaisante. Si le défaut ne peut être corrigé immédiatement mais qu'il est nécessaire de poursuivre l'exploitation, une solution temporaire adéquate doit être utilisée. Cela doit être signalé au propriétaire de l'équipement, afin que toutes les parties soient informées.
- S'assurer que les condensateurs sont déchargés : cette opération doit être effectuée en toute sécurité afin d'éviter tout risque d'étincelle.
- S'assurer qu'aucun composant ou câblage électrique sous tension n'est exposé lors de la charge, de la récupération ou de la purge du système.
- S'assurer de la continuité de la mise à la terre.

NOTICE

When replacing a component listed below, see the notes to help ensure proper operation.

Component	Notes
Compressor	Install a new drier and PTC relay.
Hot Gas Valve	<ul style="list-style-type: none">• Replace the strainer.• Use copper tube of the same diameter and length when replacing valve lines.
Evaporator Thermistor	<ul style="list-style-type: none">• Attach the new thermistor to the evaporator in the same location as the previous thermistor.• Smoothly fill the recessed area of the thermistor holder with high thermal conductive type sealant. KE-4560 RTV (manufactured by ShinEtsu Silicones) or equivalent are recommended.• Secure the thermistor with the holder.• Be very careful to prevent damage to the leads.

IV. Maintenance

The maintenance schedule below is a guideline. More frequent maintenance may be required depending on water quality, the appliance's environment, and local sanitation regulations.

⚠ WARNING

- Only qualified service technicians should service this appliance.
- Failure to install, operate, and maintain the appliance in accordance with this manual will adversely affect safety, performance, component life, and warranty coverage.
- Move the control switch to the "OFF" position and unplug the appliance from the electrical outlet before servicing.
- To reduce the risk of electric shock, do not touch the control switch or plug with damp hands.
- **CHOKING HAZARD:** Ensure all components, fasteners, and thumbscrews are securely in place after any maintenance is performed. Make sure that none have fallen into the ice storage bin.
- After service, make sure that there are no wires pinched between the panels and appliance. Make sure you do not damage or pinch the water supply line, drain line, or power cord.

A. Maintenance Schedule

The maintenance schedule below is a guideline. More frequent maintenance may be required depending on water quality, the appliance's environment, and local sanitation regulations.

Maintenance Schedule		
Frequency	Area	Task
Weekly	Scoop	Clean the scoop using a neutral cleaner. Rinse thoroughly after cleaning.
Monthly	External Water Filters	Check for proper pressure and change if necessary.
	Appliance Exterior	Wipe down with clean, soft cloth. Use a damp cloth containing a neutral cleaner to wipe off oil or dirt build up. Clean any chlorine staining (rust colored spots) using a non-abrasive cleaner like Zud or Bon Ami.
Every 3 Months	Ice Storage Bin Drain	Maintain as outlined in the instruction manual or maintenance label.
Yearly	Appliance and Ice Storage Bin	Clean and sanitize per the cleaning and sanitizing instructions provided in the instruction manual.
	Optional Drain Pump (HS-5061)	Test as outlined in "IV.B. Optional Drain Pump HS-5061."
	Water Supply Inlet	Close the icemaker water supply line shut-off valve and drain the water system. Clean the water supply inlet screen.
	Condenser	Inspect. Clean if necessary.
	Water Hoses	Inspect the water hoses and clean/replace if necessary.

B. Optional Drain Pump HS-5061

If the optional drain pump (HS-5061) is installed, test its operation at least once a year as outlined below. Note that the pump has power even when the control switch is in the "OFF" position.

- 1) Move the control switch to the "OFF" position, then unplug the appliance from the electrical outlet. **WARNING! To reduce the risk of electric shock, do not touch the control switch or plug with damp hands.**
- 2) Remove all ice from the ice storage bin.
- 3) Plug the appliance back in.
- 4) Slowly pour 24 to 30 oz. (710 to 890 ml) of water over the ice storage bin drain hole in the ice storage bin.
- 5) If water pumps out properly and the drain pump then de-energizes, proceed to step 6. If water does not pump out, confirm 115VAC to drain pump, replace as needed.
- 6) Move the control switch to the "ICE" position.
- 7) Pour another 24 to 30 oz. (710 to 890 ml) of water into the ice storage bin, then completely restrict the discharge hose while the drain pump is operating. See Fig. 2. Pour more water into the ice storage bin until the appliance turns off. The drain pump will continue to operate. Check for leaks.
- 8) Remove the discharge hose restriction and allow the water to be pumped out normally. Power to the appliance will be restored when the water in the drain pump returns to a normal level.
- 9) If the appliance fails to turn off with the discharge hose restricted or the drain pump fails to pump out the water, replace the drain pump.

Fig. 2

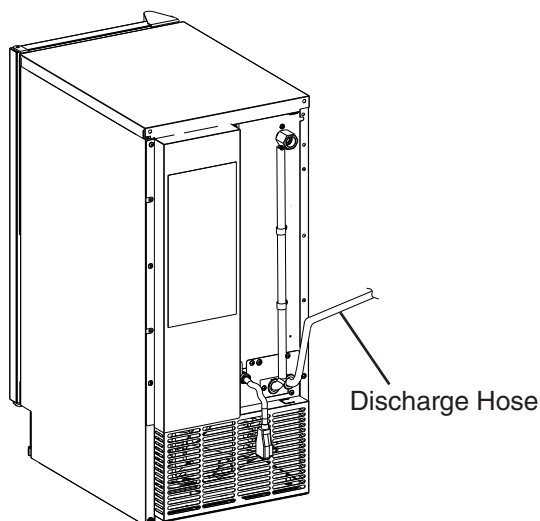

V. Preparing the Appliance for Periods of Non-Use

⚠ DANGER

Risk of Fire or Explosion. Flammable Refrigerant Used.

- Be sure to follow all Important Safety Information located at the beginning of this manual and at the beginning of section "III.A. Safety Precautions When Servicing."
- Only qualified service technicians should service this appliance.
- The appliance shall be stored in an area where the room size corresponds to the room area as specified for operation. See the nameplate or instruction manual for Minimum Room Floor Area.
- The appliance shall be stored in a room without continuously operating open flames (for example an operating gas appliance) or other potential ignition sources (for example an operating electric heater, hot surfaces).

Risque D'Incendie ou D'Explosion. Fluide Frigorigène Inflammable Utilisé.

- Assurez-vous de suivre toutes les informations importantes de sécurité qui se trouvent au début du présent manuel et au début de la section «III.A. Précautions de sécurité lors de l'entretien.»
- Seuls des techniciens de service qualifiés doivent installer et entretenir l'appareil.
- L'appareil doit être conservé dans une zone où la taille de la pièce correspond à la surface de la pièce spécifiée pour le fonctionnement.
- L'appareil doit être entreposé dans un local ne contenant pas de sources d'inflammation permanentes (flammes nues, appareil à gaz ou dispositif de chauffage électrique en fonctionnement, par exemple).

NOTICE

- During extended periods of non-use, extended absences, or in sub-freezing temperatures, follow the instructions below to reduce the risk of costly water damage.
- When the appliance is not used for two or three days under normal conditions, it is sufficient to move the control switch to the "OFF" position.

- 1) Close the water supply line shut-off valve, then open the water supply line drain valve.
- 2) Allow the line to drain by gravity.
- 3) Attach a compressed air or carbon dioxide supply to the water supply line drain.
- 4) Move the control switch to the "ICE" position.
- 5) Blow the water supply line out using the compressed air or carbon dioxide supply.
- 6) Move the control switch to the "OFF" position.
- 7) Unplug the appliance.
- 8) Close the water supply line drain valve.

- 9) Remove the water tank hose and drain the water tank.
- 10) Optional drain pump: remove the drain pump and empty the drain pump reservoir.
Replace the drain pump in its original position.
- 11) Remove all ice from the ice storage bin. Clean the ice storage bin liner using a neutral cleaner. Rinse thoroughly after cleaning.

VI. Decommissioning and Disposal



R-290 Class A3 Flammable Refrigerant Used

⚠ DANGER

Risk of Fire or Explosion. Flammable Refrigerant Used.

- Be sure to follow all Important Safety Information located at the beginning of this manual and at the beginning of section "III.A. Safety Precautions When Servicing."
- Servicing shall be done by trained service personnel with certified competence in handling flammable refrigerants to minimize the risk of possible ignition due to improper service.
- Follow handling instructions carefully in compliance with national regulations.
- Dispose of properly in accordance with federal or local regulations.
- Do not puncture refrigerant tubing. Risk of fire or explosion due to puncture of refrigerant tubing; follow handling instructions carefully.
- When removing refrigerant from a system, either for servicing or decommissioning, it is recommended good practice that all refrigerants are removed safely.
- When transferring refrigerant into cylinders, ensure that only appropriate refrigerant recovery cylinders are employed. Ensure that the correct number of cylinders for holding the total system charge is available. All cylinders to be used are designated for the recovered refrigerant and labeled for that refrigerant (i.e., special cylinders for the recovery of refrigerant). Cylinders shall be complete with pressure-relief valve and associated shut-off valves in good working order. Empty recovery cylinders are evacuated and, if possible, cooled before recovery occurs.
- The recovery equipment shall be in good working order with a set of instructions concerning the equipment that is at hand and shall be suitable for the recovery of all appropriate refrigerants including, when applicable, flammable refrigerants. In addition, a set of calibrated weighing scales shall be available and in good working order. Hoses shall be complete with leak-free disconnect couplings and in good condition. Before using the recovery machine, check that it is in satisfactory working order, has been properly maintained and that any associated electrical components are sealed to prevent ignition in the event of a refrigerant release. Consult manufacturer if in doubt.
- The recovered refrigerant shall be returned to the refrigerant supplier in the correct recovery cylinder, and the relevant waste transfer note arranged. Do not mix refrigerants in recovery units and especially not in cylinders.
- If compressors or compressor oils are to be removed, ensure that they have been evacuated to an acceptable level to make certain that flammable refrigerant does not remain within the lubricant. The evacuation process shall be carried out prior to returning the compressor to the suppliers. Only electric heating to the compressor body shall be employed to accelerate this process. When oil is drained from a system, it shall be carried out safely.

⚠ DANGER Continué

Risque D'Incendie ou D'Explosion. Fluide Frigorigène Inflammable Utilisé.

- Assurez-vous de suivre toutes les informations importantes de sécurité qui se trouvent au début du présent manuel et au début de la section «III.A. Précautions de sécurité lors de l'entretien.»
- L'entretien doit être effectué par du personnel formé et certifié pour la manipulation de réfrigérants inflammables afin de réduire au minimum le risque d'inflammation dû à un entretien inadéquat.
- Suivre attentivement les instructions de manutention conformément aux règlements nationaux.
- Mettre au rebut conformément aux règlements fédéraux ou locaux.
- Ne pas perforer la conduite de fluide frigorigène. Risque d'incendie ou d'explosion en cas de perforation d'une canalisation de fluide frigorigène; suivez attentivement les instructions de manutention.
- Lors de l'élimination du réfrigérant d'un système, que ce soit pour l'entretien ou la mise hors service, il est recommandé de veiller à ce que tous les réfrigérants soient éliminés en toute sécurité.
- Lors du transfert de réfrigérant dans des bouteilles, veillez à ce que seules des bouteilles de récupération de réfrigérant appropriées soient utilisées. Assurez-vous que le nombre de bouteilles nécessaires pour contenir la charge totale du système est disponible. Toutes les bouteilles à utiliser sont désignées pour le réfrigérant récupéré et étiquetées pour ce réfrigérant (c'est-à-dire des bouteilles spéciales pour la récupération du réfrigérant). Les bouteilles doivent être équipées d'une soupape de surpression et de soupapes d'arrêt associées en bon état de fonctionnement. Les bouteilles de récupération vides sont évacuées et, si possible, refroidies avant la récupération.
- L'équipement de récupération doit être en bon état de fonctionnement, accompagné d'un ensemble d'instructions concernant l'équipement disponible et doit être adapté à la récupération de tous les réfrigérants appropriés, y compris, le cas échéant, les réfrigérants inflammables. En outre, un ensemble de balances étalonnées doit être disponible et en bon état de fonctionnement. Les tuyaux doivent être complets, équipés de raccords de déconnexion sans fuite et en bon état. Avant d'utiliser la machine de récupération, vérifiez qu'elle est en bon état de fonctionnement, qu'elle a été correctement entretenue et que tous les composants électriques associés sont scellés pour éviter toute inflammation en cas de fuite de réfrigérant. Consulter le fabricant en cas de doute.
- Le réfrigérant récupéré doit être renvoyé au fournisseur de réfrigérant dans la bouteille de récupération appropriée et le bon de transfert de déchets correspondant doit être établi. Ne mélangez pas les réfrigérants dans les unités de récupération et surtout pas dans les bouteilles.
- Si les compresseurs ou les huiles de compresseur doivent être retirés, assurez-vous qu'ils ont été évacués à un niveau acceptable afin de s'assurer qu'il ne reste pas de réfrigérant inflammable dans le lubrifiant. Le processus d'évacuation doit être effectué avant que le compresseur ne soit renvoyé aux fournisseurs. Seul le chauffage électrique du boîtier du compresseur doit être utilisé pour accélérer ce processus. Lorsque l'huile est vidangée d'un système, cette opération doit être effectuée en toute sécurité.

The appliance contains refrigerant and must be disposed of in accordance with applicable national, state, and local codes and regulations. Refrigerant must be recovered and safely disposed of by properly trained service personnel.

Before carrying out this procedure, it is essential that the technician is completely familiar with the equipment and all its detail. It is recommended good practice that all refrigerants are recovered safely. Prior to the task being carried out, an oil and refrigerant sample shall be taken in case analysis is required prior to re-use of recovered refrigerant. It is essential that electrical power is available before the task is commenced.

- Become familiar with the equipment and its operation.
- Isolate the system electrically.
- **Before attempting the procedure, ensure that:**
 - mechanical handling equipment is available, if required, for handling refrigerant cylinders
 - all personal protective equipment is available and being used correctly
 - the recovery process is supervised at all times by a competent person
 - recovery equipment and cylinders conform to the appropriate standards
- Pump down refrigerant system, if possible.
- If a vacuum is not possible, make a manifold so that refrigerant can be removed from various parts of the system.
- Make sure that cylinder is situated on the scales before recovery takes place.
- Start the recovery machine and operate in accordance with instructions.
- Do not overfill cylinders (no more than 80% volume liquid charge).
- Do not exceed the maximum working pressure of the cylinder, even temporarily.
- When the cylinders have been filled correctly and the process completed, make sure that the cylinders and the equipment are removed from site promptly and all isolation valves on the equipment are closed off.
- Recovered refrigerant shall not be charged into another refrigerating system unless it has been cleaned and checked.

Follow the steps below for decommissioning and disposal:

1. Recovery

- 1) Recover the refrigerant, and safely dispose of the refrigerant.
- 2) Evacuate the appliance.
- 3) Purge the refrigeration system with nitrogen.
- 4) Cut out the compressor and drain and dispose of the compressor oil. Compressor oils are to be removed, ensure that they have been evacuated to an acceptable level to make certain that flammable refrigerant does not remain within the lubricant. Dispose of compressor and compressor oil in compliance with national, state, and local codes and regulations.
- 5) Purge the refrigeration system with nitrogen.

2. Labeling

Equipment shall be labeled stating that it has been decommissioned and emptied of refrigerant. The label shall be dated and signed. For appliances containing flammable refrigerant, ensure that there are labels on the equipment stating the equipment contains flammable refrigerant.

VII. Technical Information

We reserve the right to make changes in specifications and design without prior notice.

A. Specification and Performance Data

Pressure data is recorded at 5 min. into freezing cycle. The data not in bold should be used for reference only.

1. AM-50BAK(-DS)

Specification Sheet

AC SUPPLY VOLTAGE (V/Hz/PH)	~115-120/60/1	
AMPERAGE (A)	2.0	
MINIMUM CIRCUIT AMPACITY (A)	15	
MAXIMUM FUSE SIZE (A)	15	
ELECTRIC & WATER CONSUMPTION (Wtr/Air)(°C/°F)	32/21 (90/70)	21/10 (70/50)
ELECTRIC W (kWH/100 lbs.)	130 (9)	120 (5.5)
WATER gal./24HR (gal./100 lbs.)	22.6 (65)	29.4 (54)
SHAPE OF ICE	TOP HAT - Ø20mm x H 27mm	
ICE PRODUCTION PER CYCLE (lbs/kg)	0.7(0.3)	
HARVEST RATE (lbs/day)	<=1000	
APPROXIMATE STORAGE CAPACITY (lbs/kg)	27 (12.5)	
CUBE CONTROL SYSTEM	Thermistor, Timer	
HARVESTING CONTROL SYSTEM	Thermistor, Hot Gas	
ICE MAKING WATER CONTROL	Thermistor, Timer	
BIN CONTROL SYSTEM	Thermistor	
REFRIGERANT CHARGE (g/oz.)	R290, 65 (2.3)	
FOAM BLOWING AGENT	HFO 1233zd (E)	
DESIGN PRESSURE (PSIG/kPa)	HI-300 (2069) LO-130 (897)	

Performance Data Sheet

APPROXIMATE ICE PRODUCTION PER 24 HR.	AMBIENT TEMP. (°F/°C)	WATER TEMP. (°F/°C)					
		50/10		70/21		90/32	
lbs./day (kg./day)	70/21	54	<u>25</u>	49	<u>22</u>	46	<u>21</u>
	80/27	50	<u>23</u>	41	<u>19</u>	42	<u>19</u>
	90/32	49	<u>22</u>	35	<u>16</u>	34	<u>15</u>
	100/38	50	<u>23</u>	35	<u>16</u>	33	<u>15</u>
APPROXIMATE ELECTRIC CONSUMPTION watts	70/21	120		123		139	
	80/27	122		127		150	
	90/32	123		130		151	
	100/38	130		135		170	
APPROXIMATE WATER CONSUMPTION PER 24 HR. gal./day (m ³ /day)	70/21	29	<u>0.11</u>	27	<u>0.10</u>	26	<u>0.10</u>
	80/27	28	<u>0.11</u>	25	<u>0.09</u>	24	<u>0.09</u>
	90/32	27	<u>0.10</u>	23	<u>0.09</u>	22	<u>0.08</u>
	100/38	25	<u>0.09</u>	22	<u>0.08</u>	21	<u>0.08</u>
FREEZING CYCLE TIME min.	70/21	16.6		17.7		20.1	
	80/27	17.4		19.1		22.1	
	90/32	17.7		20.3		23.1	
	100/38	18.5		20.9		25.7	
HARVEST CYCLE TIME min.	70/21	4.1		3.8		3.5	
	80/27	3.9		3.4		3.2	
	90/32	3.8		3.0		2.8	
	100/38	3.4		3.0		2.6	
HEAD PRESSURE PSIG (kg/cm ² G)	70/21	179	<u>12.6</u>	197	<u>13.8</u>	217	<u>15.3</u>
	80/27	192	<u>13.5</u>	220	<u>15.4</u>	238	<u>16.7</u>
	90/32	197	<u>13.8</u>	239	<u>16.8</u>	259	<u>18.2</u>
	100/38	199	<u>14.0</u>	244	<u>17.1</u>	277	<u>19.5</u>
SUCTION PRESSURE PSIG (kg/cm ² G)	70/21	33	<u>2.3</u>	35	<u>2.5</u>	38	<u>2.7</u>
	80/27	35	<u>2.4</u>	38	<u>2.7</u>	41	<u>2.9</u>
	90/32	35	<u>2.5</u>	41	<u>2.9</u>	44	<u>3.1</u>
	100/38	36	<u>2.5</u>	42	<u>2.9</u>	46	<u>3.2</u>
TOTAL HEAT OF REJECTION FROM CONDENSER	1,200 BTU/h [AT 90°F (32°C) / WT 70°F (21°C)]						
TOTAL HEAT OF REJECTION FROM COMPRESSOR	200 BTU/h [AT 90°F (32°C) / WT 70°F (21°C)]						

2. AM-50BAK-AD(-ADDS)

Specification Sheet

AC SUPPLY VOLTAGE (V/Hz/PH)	~115-120/60/1	
AMPERAGE (A)	2.0	
MINIMUM CIRCUIT AMPACITY (A)	15	
MAXIMUM FUSE SIZE (A)	15	
ELECTRIC & WATER CONSUMPTION(Wtr/Air)(°C/°F)	32/21 (90/70)	21/10 (70/50)
ELECTRIC W (kWH/100 lbs.)	130 (9)	120 (5.5)
WATER gal./24HR (gal./100 lbs.)	22.6 (65)	29.4 (54)
SHAPE OF ICE	TOP HAT - Φ20mm x H 27mm	
ICE PRODUCTION PER CYCLE(lbs/kg)	0.7 (0.3)	
HARVEST RATE (lbs/day)	<=1000	
APPROXIMATE STORAGE CAPACITY(lbs/kg)	27 (12.5)	
CUBE CONTROL SYSTEM	Thermistor, Timer	
HARVESTING CONTROL SYSTEM	Thermistor, Hot Gas	
ICE MAKING WATER CONTROL	Thermistor, Timer	
BIN CONTROL SYSTEM	Thermistor	
REFRIGERANT CHARGE g (oz.)	R-290, 60 (2.1)	
FOAM BLOWING AGENT	HFO 1233zd(E)	
DESIGN PRESSURE(PSIG/kPa)	HI-300 (2069) LO-130 (897)	

Performance Data Sheet

APPROXIMATE ICE PRODUCTION PER 24 HR.	AMBIENT TEMP. (°F/°C)	WATER TEMP. (°F/°C)					
		50/10		70/21		90/32	
	70/21	54	<u>25</u>	49	<u>22</u>	46	<u>21</u>
	80/27	50	<u>23</u>	41	<u>19</u>	42	<u>19</u>
	90/32	49	<u>22</u>	35	<u>16</u>	34	<u>15</u>
lbs./day kg./day	100/38	50	<u>23</u>	35	<u>16</u>	33	<u>15</u>
APPROXIMATE ELECTRIC CONSUMPTION	70/21	120		123		139	
	80/27	122		127		150	
	90/32	123		130		151	
watts	100/38	130		135		170	
APPROXIMATE WATER CONSUMPTION PER 24 HR.	70/21	29	<u>0.11</u>	27	<u>0.10</u>	26	<u>0.10</u>
	80/27	28	<u>0.11</u>	25	<u>0.09</u>	24	<u>0.09</u>
	90/32	27	<u>0.10</u>	23	<u>0.09</u>	22	<u>0.08</u>
gal./day m ³ /day	100/38	25	<u>0.09</u>	22	<u>0.08</u>	21	<u>0.08</u>
FREEZING CYCLE TIME	70/21	16.6		17.7		20.1	
	80/27	17.4		19.1		22.1	
	90/32	17.7		20.3		23.1	
min.	100/38	18.5		20.9		25.7	
HARVEST CYCLE TIME	70/21	4.1		3.8		3.5	
	80/27	3.9		3.4		3.2	
	90/32	3.8		3.0		2.8	
min.	100/38	3.4		3.0		2.6	
HEAD PRESSURE	70/21	179	<u>12.6</u>	197	<u>13.8</u>	217	<u>15.3</u>
	80/27	192	<u>13.5</u>	220	<u>15.4</u>	238	<u>16.7</u>
	90/32	197	<u>13.8</u>	239	<u>16.8</u>	259	<u>18.2</u>
PSIG kg/cm ² G	100/38	199	<u>14.0</u>	244	<u>17.1</u>	277	<u>19.5</u>
SUCTION PRESSURE	70/21	33	<u>2.3</u>	35	<u>2.5</u>	38	<u>2.7</u>
	80/27	35	<u>2.4</u>	38	<u>2.7</u>	41	<u>2.9</u>
	90/32	35	<u>2.5</u>	41	<u>2.9</u>	44	<u>3.1</u>
PSIG kg/cm ² G	100/38	36	<u>2.5</u>	42	<u>2.9</u>	46	<u>3.2</u>
TOTAL HEAT OF REJECTION FROM CONDENSER	1,200 BTU/h [AT 90°F (32°C) / WT 70°F (21°C)]						
TOTAL HEAT OF REJECTION FROM COMPRESSOR	200 BTU/h [AT 90°F (32°C) / WT 70°F (21°C)]						

B. Wiring Diagrams

1. AM-50BAK(-DS)(-AD)(-ADDS)

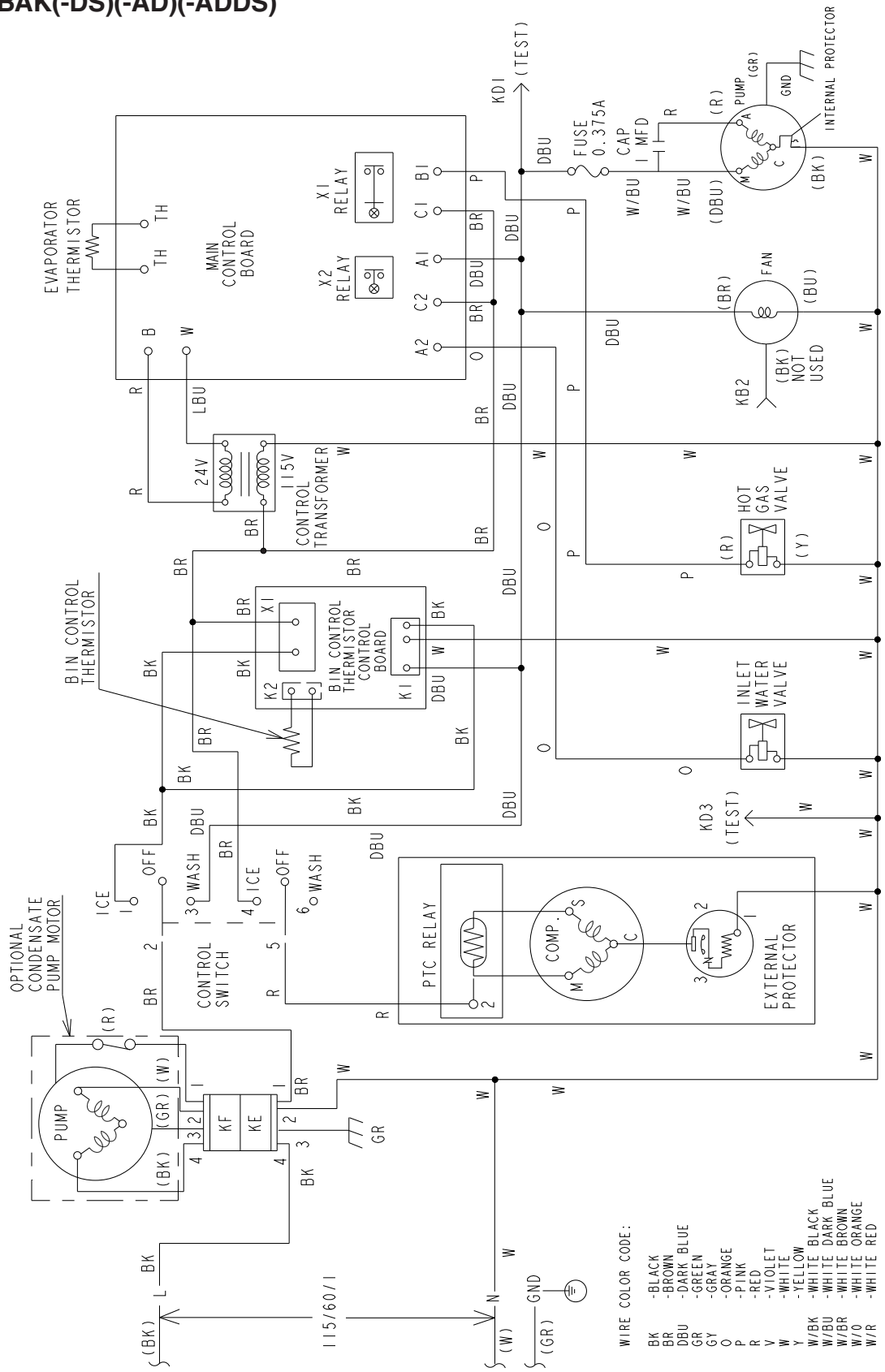

2. HS-5061 Optional Drain Pump

