



# HOSHIZAKI

## Service Manual

Modular Crescent Cuber

Model  
KM-830MAK2



[hoshizakiamerica.com](http://hoshizakiamerica.com)

Number: 73276  
Issued: 4-1-2026

**⚠ WARNING**

Only qualified service technicians should install and service the appliance. To obtain the name and phone number of your local Hoshizaki Certified Service Representative, visit [www.hoshizakiamerica.com](http://www.hoshizakiamerica.com). No service should be undertaken until the technician has thoroughly read this Service Manual. Failure to service and maintain the appliance in accordance with this manual will adversely affect safety, performance, component life, and warranty coverage. Proper installation is the responsibility of the installer. Product failure or property damage due to improper installation is not covered under warranty.

Hoshizaki provides this manual primarily to assist qualified service technicians in the service of the appliance.

Should the reader have any questions or concerns which have not been satisfactorily addressed, please call, send an e-mail message, or write to the Hoshizaki Technical Support Department for assistance.

Phone: 1-800-233-1940; (770) 487-2331

E-mail: [tech-support@hoshizaki.com](mailto:tech-support@hoshizaki.com)

**HOSHIZAKI AMERICA, INC.**

618 Highway 74 South  
Peachtree City, GA 30269  
Attn: Hoshizaki Technical Support Department

**NOTE:** To expedite assistance, all correspondence/communication **MUST** include the following information:

- Model Number \_\_\_\_\_
- Serial Number \_\_\_\_\_
- Complete and detailed explanation of the problem.

## **IMPORTANT**

This manual should be read carefully before the appliance is serviced. Read the warnings and guidelines contained in this manual carefully as they provide essential information for the continued safe use, service, and maintenance of the appliance. Retain this manual for any further reference that may be necessary.

## **CONTENTS**

Important Safety Information .....	5
I. Construction and Water/Refrigeration Circuit Diagram .....	10
A. Construction .....	10
B. Water/Refrigeration Circuit Diagram .....	11
II. Sequence of Operation and Service Diagnosis .....	12
A. Sequence of Operation Flow Chart .....	12
1. Operation Flow Chart .....	12
2. Shutdown Flow Chart .....	13
3. Freeze-Up Detection (FUD) Flow Chart .....	14
III. Service Diagnosis, Refrigeration Circuit Service, and Component Service .....	15
A. Safety Precautions When Servicing   Précautions de sécurité lors de l'entretien .....	15
1. English .....	15
2. Français .....	20
B. Service Diagnosis .....	25
1. Diagnostic Procedure .....	26
2. Sequence and Component Diagnosis .....	26
4. Control Board Check .....	34
5. Bin Control Check .....	36
6. Float Switch Check and Cleaning .....	38
a) Float Switch Check .....	38
b) Float Switch Cleaning .....	39
7. Thermistor Check .....	40
8. Control Switch .....	40
9. Mode Switch .....	40
10. Diagnostic Tables .....	41
11. Freeze-Up Check List .....	45
12. Control Board, Control Board Layout, Settings, and Adjustments .....	46
13. Control Board Layout .....	47
14. LED Lights and Audible Alarm Safeties .....	48
15. Settings and Adjustments .....	49
C. Refrigeration Circuit Service .....	55
D. Component Service Information .....	61

IV. Maintenance .....	63
V. Preparing the Icemaker for Periods of Non-Use .....	64
VI. Decommissioning and Disposal .....	65
VII. Technical Information.....	69
A. Specification and Performance Data Sheets.....	69
B. Wiring Diagram .....	70

## Important Safety Information

Throughout this manual, notices appear to bring your attention to situations which could result in death, serious injury, damage to the appliance, or damage to property. Models covered in this manual utilize either R-290 or R-448A refrigerant. See the nameplate or the Electrical and Refrigerant Data section of this manual for the refrigerant type in your model.

	<b>R-290 Class A3 Flammable Refrigerant Used</b>
<b>⚠ DANGER</b>	<b>Indicates a hazardous situation that, if not avoided, will result in death or serious injury.</b>
<b>⚠ WARNING</b>	<b>Indicates a hazardous situation that, if not avoided, could result in death or serious injury.</b>
<b>NOTICE</b>	<b>Indicates a situation that, if not avoided, could result in damage to the appliance or property.</b>
<b>IMPORTANT</b>	<b>Indicates important information about the use and care of the appliance.</b>
<b>⚠ DANGER</b>	
<p><b><u>Risk of Fire or Explosion</u></b>  <b><u>Flammable Refrigerant Used</u></b></p> <ul style="list-style-type: none"> <li>• Qualified service technicians are those having the appropriate technical training and experience necessary to be aware of hazards to which they are exposed in performing a task and of measures necessary to minimize the danger to themselves or other persons.</li> <li>• No service should be undertaken until the technician has thoroughly read this Service Manual. All safety precautions must be followed.</li> <li>• This appliance to be installed in accordance with the Safety Standard for Refrigeration Systems ANSI/ASHRAE 15.</li> <li>• Follow handling instructions carefully in compliance with national regulations.</li> <li>• Do not use mechanical devices or other means to accelerate the defrosting process or to clean, other than those recommended by the manufacturer.</li> <li>• Do not puncture refrigerant tubing. Risk of fire or explosion due to puncture of refrigerant tubing; follow handling instructions carefully.</li> </ul>	<ul style="list-style-type: none"> <li>• Servicing shall be done by trained service personnel with certified competence in handling flammable refrigerants to minimize the risk of possible ignition due to incorrect parts or improper service.</li> <li>• Component parts shall be replaced with like components, so as to minimize the risk of possible ignition due to incorrect parts.</li> <li>• Dispose of properly in accordance with federal or local regulations.</li> <li>• Do not pierce or burn.</li> <li>• Be aware that refrigerants may not contain an odor.</li> <li>• Do not damage the refrigeration circuit.</li> <li>• See nameplate for R-290 refrigerant charge:             <ul style="list-style-type: none"> <li>• If greater than 114 g (4 oz.), do not install in public corridor or lobby.</li> <li>• If greater than 152 g (5.3 oz.), do not install within 6 m (20 ft) of open flame.</li> </ul> </li> <li>• The appliance shall be stored in a room without continuously operating ignition sources (for example: open flames, an operating gas appliance, or an operating electric heater).</li> </ul>

## **⚠ DANGER continued**

- Do not place any potential ignition sources in or near the appliance.
- Keep clear of obstruction all ventilation openings in the appliance enclosure or in the structure for building-in.
- No potential sources of ignition are to be used in the searching for or detection of refrigerant leaks.
- Do not use electrical appliances inside the appliance unless they are of the type recommended by the manufacturer.
- Do not store explosive substances such as aerosol cans with a flammable propellant in this appliance.
- Check that cabling will not be subject to wear, corrosion, excessive pressure, vibration, sharp edges, or any other adverse environmental effects. The check shall also take into account the effects of aging or continual vibration from sources such as compressors or fans.
- Ensure that the area is in the open or that it is adequately ventilated before breaking into the system or conducting any hot work. A degree of ventilation shall continue during the period that the work is carried out. The ventilation should safely disperse any released refrigerant and preferably expel it externally into the atmosphere.
- Models utilizing R-290 refrigerant shall be used on a dispenser unit/ice storage bin without electrical components or one designed to be used with flammable refrigerants, and of a size or type as indicated in this manual.

### **Risque D'Incendie ou D'Explosion Fluide Frigorigène Inflammable Utilisé**

- Les techniciens de service qualifiés sont ceux qui possèdent la formation technique et l'expérience nécessaires pour être conscients des dangers auxquels ils sont exposés dans l'accomplissement d'une tâche et des mesures nécessaires pour réduire au minimum le danger pour eux-mêmes ou pour d'autres personnes.
- Aucune opération d'entretien ne doit être entreprise avant que le technicien n'ait lu attentivement ce manuel. Toutes les précautions de sécurité doivent être suivies.
- Cet appareil doit être installé conformément à la norme de sécurité pour les systèmes de réfrigération ANSI/ASHRAE 15.
- Suivez attentivement les instructions de manutention conformément aux règlements nationaux.
- Ne pas utiliser de dispositifs mécaniques ou d'autres moyens pour accélérer le processus de dégivrage ou pour nettoyer, autres que ceux recommandés par le fabricant.
- Ne pas perforer la conduite de fluide frigorigène. Risque d'incendie ou d'explosion en cas de perforation d'une canalisation de fluide frigorigène; suivez attentivement les instructions de manutention.
- L'entretien doit être effectué par du personnel formé et certifié pour la manipulation de réfrigérants inflammables afin de réduire au minimum le risque d'inflammation dû à des pièces incorrectes ou à un entretien inadéquat.
- Les pièces doivent être remplacées par des pièces similaires, de manière à réduire au minimum le risque d'inflammation dû à des pièces incorrectes.

## **⚠ DANGER continué**

- Mettre au rebut conformément aux règlements fédéraux ou locaux.
- Ne pas percer ou brûler.
- Attention, les fluides frigorigènes peuvent ne pas dégager d'odeur.
- Ne pas endommager les composants du circuit de réfrigération.
- Voir plaque signalétique pour la charge de réfrigérant R-290:
  - Si elle est supérieure à 114 g (4 oz.), ne pas l'installer dans un couloir public ou un hall d'entrée.
  - Si elle est supérieure à 152 g (5.3 oz.), ne pas l'installer à moins de 6 m (20 pi) d'une flamme nue.
- L'appareil doit être entreposé dans un local ne contenant pas de sources d'inflammation permanentes (flammes nues, appareil à gaz ou dispositif de chauffage électrique en fonctionnement, par exemple).
- Ne placer aucune source d'inflammation potentielle à l'intérieur ou à proximité de l'appareil.
- Ne pas obstruer les ouvertures de ventilation dans l'enceinte de l'appareil ou dans la structure d'encastrement.
- Aucune source potentielle d'inflammation ne doit être utilisée pour rechercher ou détecter des fuites de réfrigérant.
- Ne pas utiliser d'appareils électriques à l'intérieur de l'appareil, sauf s'ils sont du type recommandé par le fabricant.
- Ne pas entreposer dans cet appareil des substances explosives telles que des bombes aérosols contenant un gaz propulseur inflammable.
- Vérifier que le câblage ne sera pas soumis à l'usure, à la corrosion, à une pression excessive, à des vibrations, à des arêtes vives ou à tout autre effet environnemental négatif. Le contrôle doit également prendre en compte les effets du vieillissement ou des vibrations continues provenant de sources telles que les compresseurs ou les ventilateurs.
- S'assurer que la zone est à l'air libre ou qu'elle est correctement ventilée avant de pénétrer dans le système ou d'effectuer un travail à chaud. Une certaine ventilation doit être maintenue pendant la durée des travaux. La ventilation doit permettre de disperser en toute sécurité tout réfrigérant libéré et, de préférence, de l'expulser dans l'atmosphère.
- Les modèles utilisant le réfrigérant R-290 doivent être utilisés sur un bac de stockage/distributeur de glace sans composants électriques ou sur un modèle conçu pour être utilisé avec des réfrigérants inflammables, et d'une taille ou d'un type tel qu'indiqué dans ce manuel.

## WARNING

The appliance should be destined only to the use for which it has been expressly conceived. Any other use should be considered improper and therefore dangerous. The manufacturer cannot be held responsible for injury or damage resulting from improper, incorrect, and unreasonable use. Failure to service and maintain the appliance in accordance with this manual will adversely affect safety, performance, component life, and warranty coverage and may result in costly water damage.

**To reduce the risk of death, electric shock, serious injury, or fire, follow basic precautions including the following:**

- This appliance is not intended for use above 2,000 m (6,561 ft). Installation above 2,000 m (6,561 ft) may adversely affect safety, performance, and component life.
- Wear appropriate personal protective equipment (PPE) when servicing the appliance.
- Moving parts (e.g., fan blade) can crush and cut. Keep hands clear.
- The appliance must be installed in accordance with applicable national, state, and local codes and regulations. Failure to meet these code requirements could result in death, electric shock, serious injury, fire, or damage.
- Do not make any alterations to the appliance. Alterations could result in electric shock, injury, fire, or damage to the appliance.
- Appliance is heavy. Use care when lifting or positioning. Work in pairs when needed to prevent injury or damage.
- The appliance requires an independent power supply of proper capacity. See the nameplate for electrical specifications. Failure to use an independent power supply of proper capacity can result in a tripped breaker, blown fuse, damage to existing wiring, or component failure. This could lead to heat generation or fire.
- **THE APPLIANCE MUST BE GROUNDED.** Failure to follow these instructions may result in death, electric shock, or fire.
- Risk of electric shock. Use extreme caution and exercise safe electrical practices.
- Risk of electric shock. Control switch in "OFF" position does not de-energize all loads.
- To reduce the risk of electric shock, do not touch the control switch or plug with damp hands.
- To reduce the risk of electric shock, make sure the control switch is in the "OFF" position before servicing the appliance.
- The appliance is not intended for use by persons (including children) with reduced physical, sensory, or mental capabilities, or lack of experience and knowledge, unless they have been given supervision or instruction concerning use of the appliance by a person responsible for their safety.
- Do not splash, pour, or spray water directly onto or into the appliance. This might cause short circuit, electric shock, corrosion, or failure.
- Children should be supervised to ensure that they do not play with the appliance.
- Do not climb, stand, or hang on the appliance or allow children or animals to do so. Death or serious injury could occur or the appliance could be damaged.

**⚠ WARNING continued**

- Do not climb, stand, or hang on the appliance or allow children or animals to do so. Death or serious injury could occur or the appliance could be damaged.
- Do not use combustible spray or place volatile or flammable substances in or near the appliance. They might catch fire.
- Keep the area around the appliance clean. Dirt, dust, or insects in the appliance could cause harm to individuals or damage to the appliance.

**NOTICE**

- Follow the water supply, drain connection, and maintenance instructions in the instruction manual carefully to reduce the risk of costly water damage.
- In areas where water damage is a concern, install in a contained area with a floor drain.
- Install the appliance in a location that stays above freezing. Normal operating ambient temperature must be within 45°F to 100°F (7°C to 38°C).
- To help ensure that the ice storage bin drain remains clear, follow the Ice Storage Bin Drain instructions in the instruction manual once every 3 months or as often as necessary for conditions. If the ice storage bin drain becomes clogged, water could build up in the bin and overflow, leading to costly water damage.
- Do not leave the appliance on during extended periods of non-use, extended absences, or in sub-freezing temperatures. To properly prepare the appliance for these occasions, follow the instructions in "V. Preparing the Appliance for Periods of Non-Use."
- If water collects in the bin and will not drain, turn off the appliance and close the water supply line shut-off valve.

**NOTICE Continued**

- If water seeps from the base of the appliance, turn off the appliance and close the water supply line shut-off valve. Failure to do so could lead to costly water damage.
- Do not place objects on top of the appliance.
- The dispenser unit/ice storage bin is for ice use only. Do not store anything else in the dispenser unit/ice storage bin.
- Protect the floor when moving the appliance to prevent damage to the floor.

# I. Construction and Water/Refrigeration Circuit Diagram

## A. Construction

### 1. Air-Cooled (MAK2)

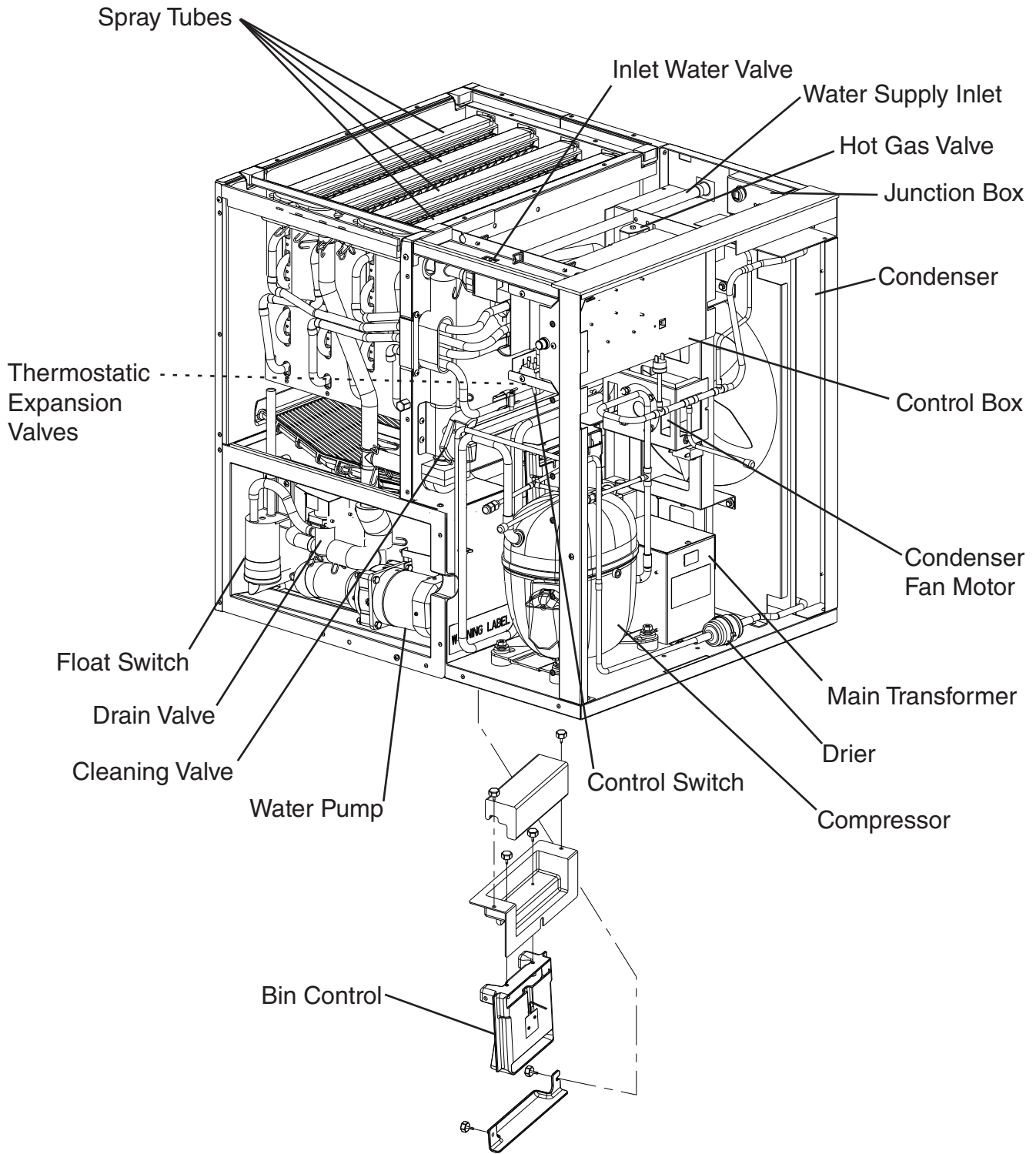

# B. Water/Refrigeration Circuit Diagram

## 1. Air-Cooled Models (MAK2)

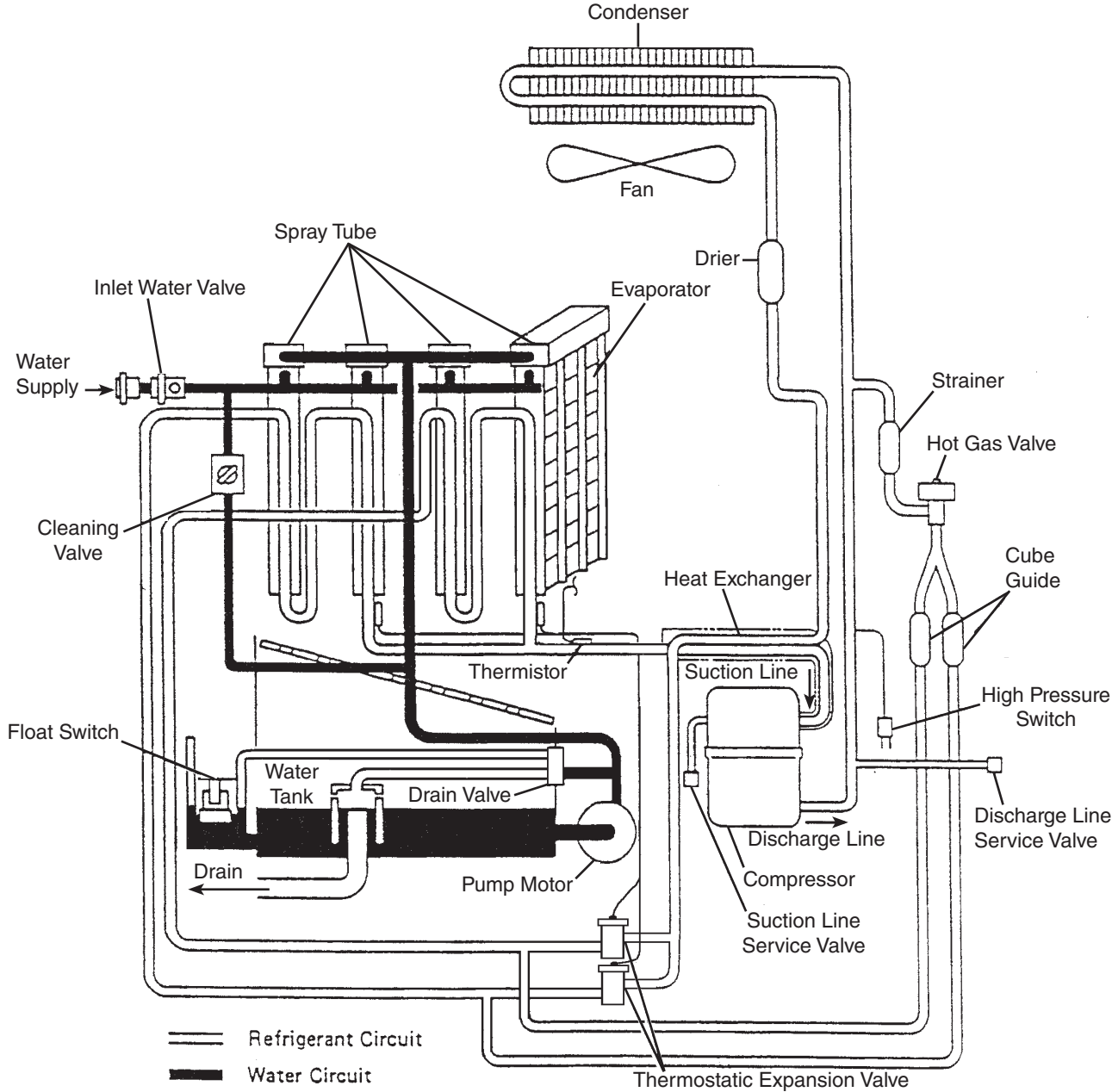

## II. Sequence of Operation and Service Diagnosis

### A. Sequence of Operation Flow Chart

#### 1. Operation Flow Chart

### Operation Flow Chart

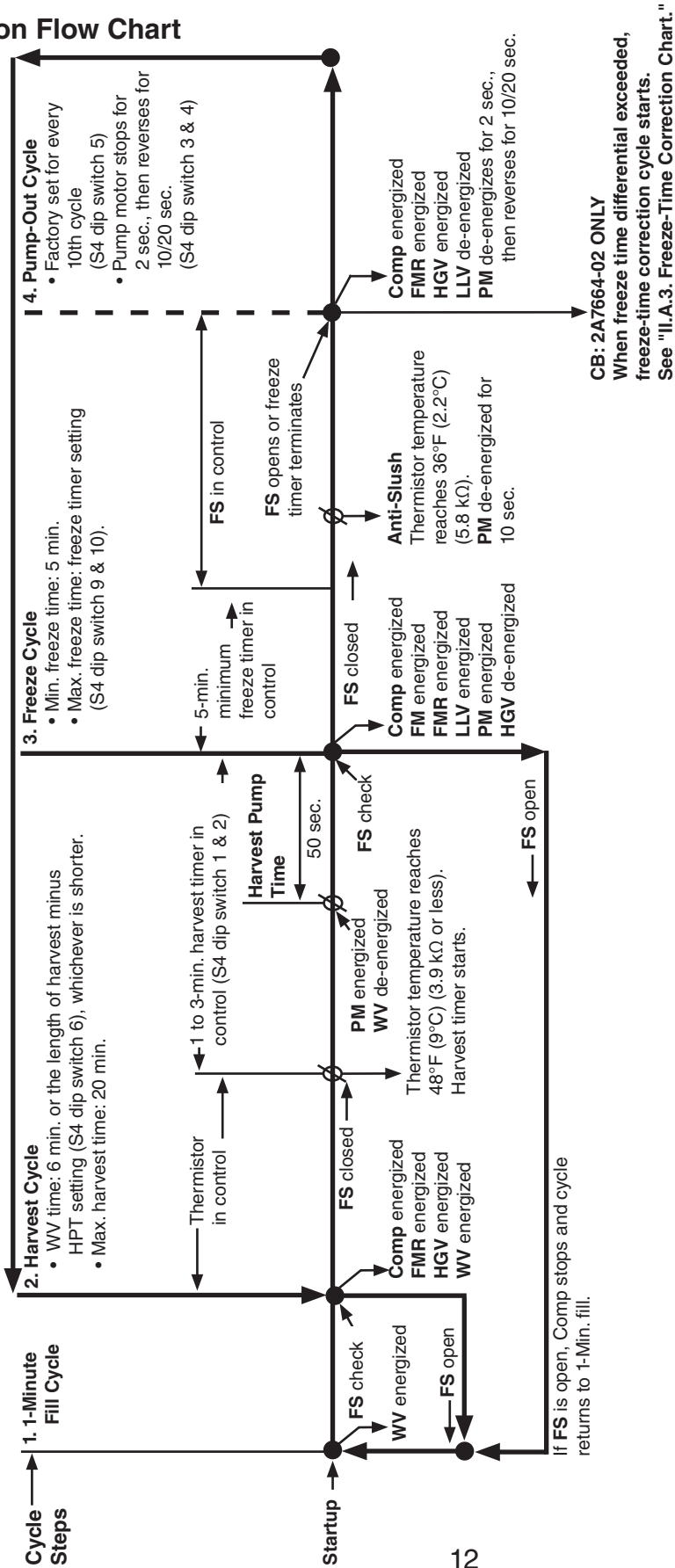

**Legend:**  
 BC—bin control  
 CB—control board  
 Comp—compressor  
 FM—fan motor  
 FMR—fan motor-remote  
 FS—float switch  
 HGV—hot gas valve  
 HPT—harvest pump time  
 LLLV—liquid line valve  
 PM—pump motor  
 WV—inlet water valve

**Components Energized when the Control Switch is in the "WASH" Position**  
 The "WASH" position on the control switch is used when cleaning and sanitizing the unit. When in the "WASH" position, power is supplied to the pump motor. With the cleaning valve closed, the cleaner and sanitizer flow over the outside of the evaporator plate assembly. With the cleaning valve open, the cleaner and sanitizer flow over both the outside and the inside of the evaporator plate assembly.  
 Note: Close the cleaning valve after cleaning and sanitizing are complete, otherwise the unit will not restart when the control switch is placed in the "ICE" position.

## 2. Shutdown Flow Chart

### Shutdown Flow Chart

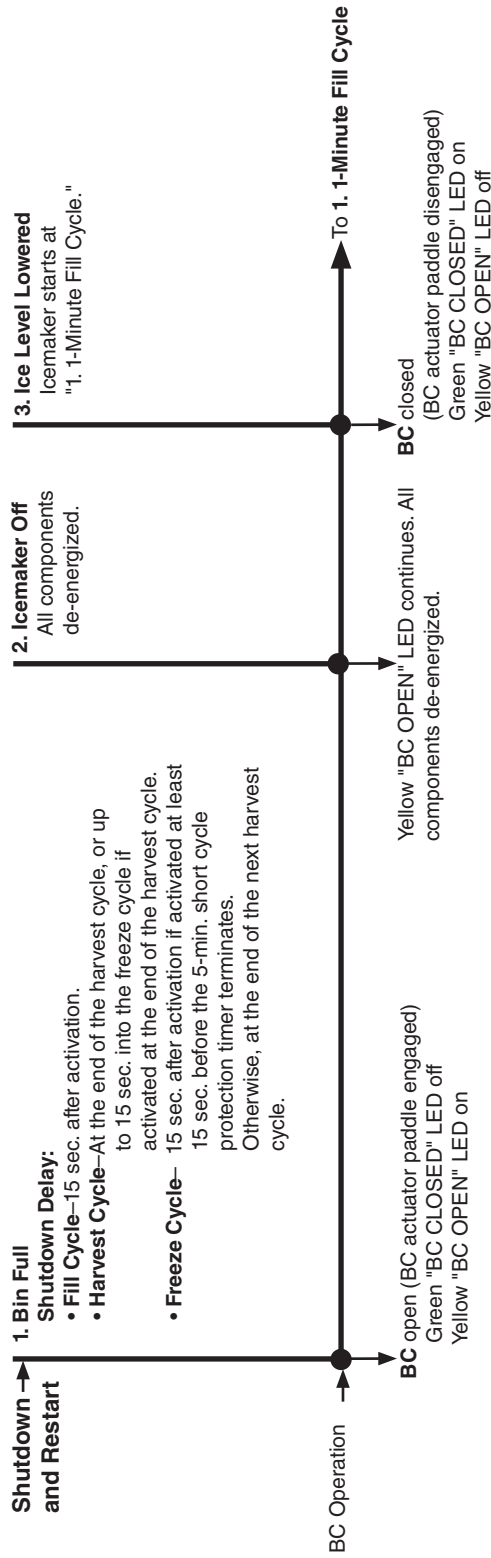

**Control board 2A7664-02 ONLY - retains freeze-time correction count data between bin control restarts.**

**Legend:**  
BC—bin control

### 3. Freeze-Up Detection (FUD) Flow Chart

## FUD Initiated Operation Flow Chart "POWER" LED Blinking FUD Harvest Cycle

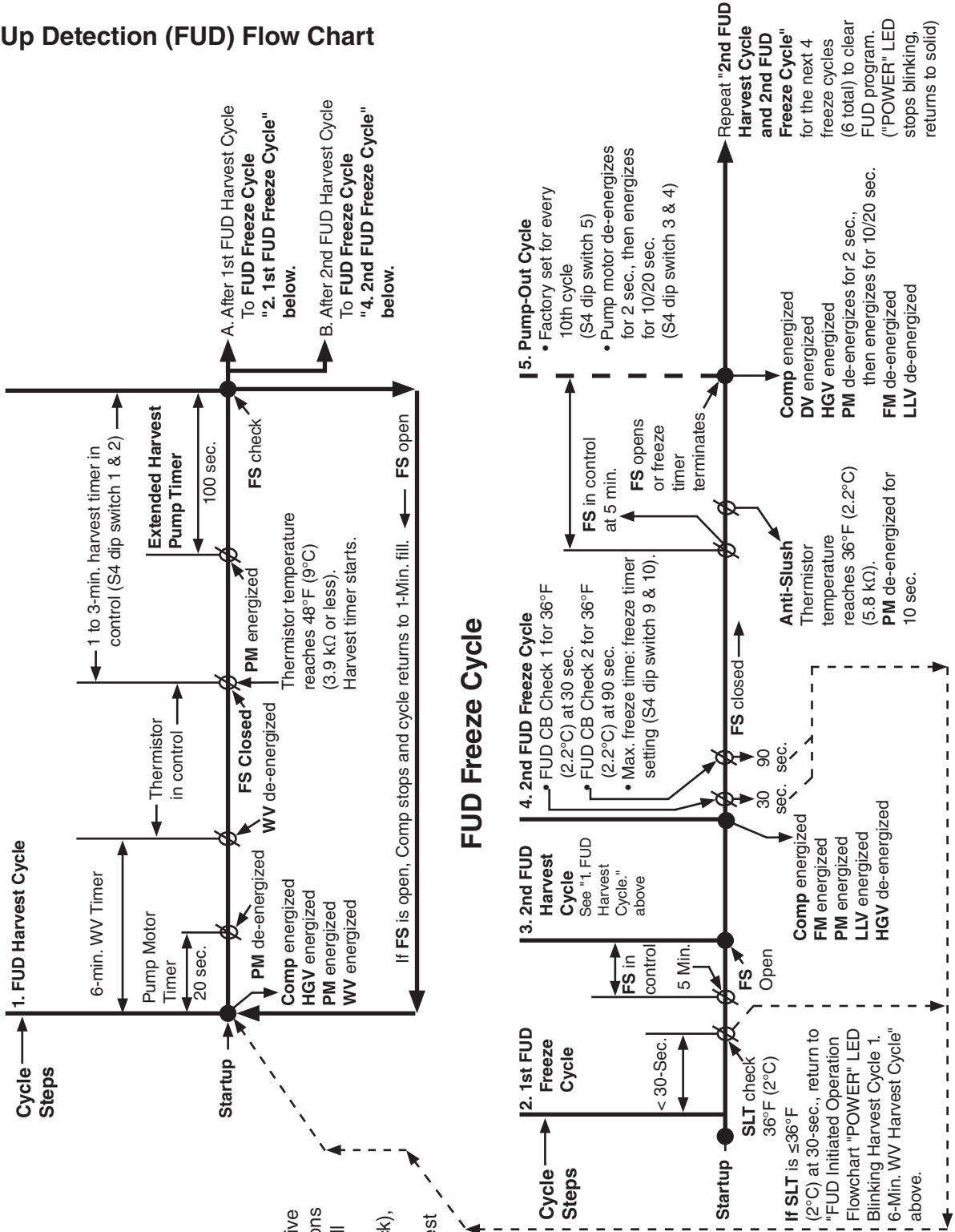

**FUD Initiation -**  
See "III.B.3.1) FUD Cycle Initiation.

**Note:**

- "POWER" LED starts blinking when FUD is initiated, and continues until the completion of 6 normal freeze cycles or CB is manually reset. See "III.B.3.5) FUD Modified Harvest Cycle Reset."
- In case of three consecutive FUD harvest cycle initiations in a row, the next cycle will be a normal FS activated freeze cycle (no SLT check), followed by a normal thermistor activated harvest cycle. "Power" LED continues to blink.

**Legend:**

- CB—control board
- Comp—compressor
- FM—fan motor
- FS—float switch
- FUD—freeze up detection
- HGV—hot gas valve
- PM—pump motor
- SLT—suction line temperature
- WV—inlet water valve

### III. Service Diagnosis, Refrigeration Circuit Service, and Component Service

#### A. Safety Precautions When Servicing | Précautions de sécurité lors de l'entretien

##### 1. English



#### R-290 Class A3 Flammable Refrigerant Used

#### **⚠ DANGER**

##### **Risk of Fire or Explosion. Flammable Refrigerant Used.**

- Be sure to follow all Important Safety Information located at the beginning of this manual and in this section.
- The appliance should be diagnosed and repaired only by qualified service personnel to reduce the risk of death, electric shock, serious injury, or fire.
- Servicing shall be done by trained service personnel with certified competence in handling flammable refrigerants to minimize the risk of possible ignition due to incorrect parts or improper service.
- Follow handling instructions carefully in compliance with national regulations.
- Do not use mechanical devices or other means to accelerate the defrosting process or to clean, other than those recommended by the manufacturer.
- Be aware that refrigerants may not contain an odor.
- Do not puncture refrigerant tubing. Risk of fire or explosion due to puncture of refrigerant tubing; follow handling instructions carefully.
- Component parts shall be replaced with like components. So as to minimize the risk of possible ignition due to incorrect parts.
- Do not place any potential ignition sources in or near the appliance.
- Prior to beginning work on systems containing flammable refrigerants, safety checks are necessary to ensure that the risk of ignition is minimized.
- All maintenance staff and others working in the local area shall be instructed on the nature of work being carried out. Work in confined spaces shall be avoided.
- Work shall be undertaken under a controlled procedure so as to minimize the risk of a flammable gas or vapor being present while the work is being performed.
- The area shall be checked with an appropriate refrigerant detector prior to and during work, to ensure the technician is aware of potentially toxic or flammable atmospheres.
- Ensure that the leak detection equipment being used is suitable for use with all applicable refrigerants, i.e., nonsparking, adequately sealed, or intrinsically safe.  
NOTE: The use of silicone sealant can inhibit the effectiveness of some types of leak detection equipment.

## **⚠ DANGER continued**

- Under no circumstances shall potential sources of ignition be used in the searching for or detection of refrigerant leaks. A halide torch (or any other detector using a naked flame) shall not be used.
- The following leak detection methods are deemed acceptable for all refrigerant systems:
  - Electronic leak detectors may be used to detect refrigerant leaks but, in the case of flammable refrigerants, the sensitivity might not be adequate, or might need recalibration. (Detection equipment shall be calibrated in a refrigerant-free area.) Ensure that the detector is not a potential source of ignition and is suitable for the refrigerant used. Leak detection equipment shall be set at a percentage of the LFL of the refrigerant and shall be calibrated to the refrigerant employed, and the appropriate percentage of gas (25% maximum) is confirmed.
  - Leak detection fluids are also suitable for use with most refrigerants but the use of detergents containing chlorine shall be avoided as the chlorine can react with the refrigerant and corrode the copper pipe-work.  
Note: Examples of leak detection fluids are:
    - bubble method
    - fluorescent method agents
- If any hot work is to be conducted on the refrigerating equipment or any associated parts, appropriate fire extinguishing equipment shall be available on hand. A dry chemical or CO<sub>2</sub> fire extinguisher should be adjacent to the charging area. You must have a Class B chemical fire extinguisher available at all times.
- No person carrying out work in relation to a refrigerating system which involves exposing any pipe work shall use any sources of ignition in such a manner that it may lead to the risk of fire or explosion. All possible ignition sources, including cigarette smoking, should be kept sufficiently far away from the site of installation, repairing, removing, and disposal, during which refrigerant can possibly be released to the surrounding space. Prior to work taking place, the area around the equipment shall be surveyed to make sure that there are no flammable hazards or ignition risks. "No Smoking" signs shall be displayed.
- Ensure that the area is in the open or that it is adequately ventilated before breaking into the system or conducting any hot work. A degree of ventilation shall continue during the period that the work is carried out. The ventilation should safely disperse any released refrigerant and preferably expel it externally into the atmosphere.
- When breaking into the refrigerant circuit to make repairs – or for any other purpose – conventional procedures shall be used. However, for flammable refrigerants it is important that best practice be followed, since flammability is a consideration. The following procedure shall be adhered to:
  - safely remove refrigerant following local and national regulations
  - purge the circuit with inert gas
  - evacuate (optional for A2L)
  - purge with inert gas (optional for A2L)
  - open the circuit by cutting or brazing

## **⚠ DANGER continued**

- If a leak is suspected, all naked flames shall be removed/extinguished.
- If a leakage of refrigerant is found which requires brazing, all of the refrigerant shall be recovered from the system, or isolated (by means of shut off valves) in a part of the system remote from the leak.
- When removing refrigerant from a system, either for servicing or decommissioning, it is recommended good practice that all refrigerants are removed safely.
- When transferring refrigerant into cylinders, ensure that only appropriate refrigerant recovery cylinders are employed. Ensure that the correct number of cylinders for holding the total system charge is available. All cylinders to be used are designated for the recovered refrigerant and labeled for that refrigerant (i.e., special cylinders for the recovery of refrigerant). Cylinders shall be complete with pressure-relief valve and associated shut-off valves in good working order. Empty recovery cylinders are evacuated and, if possible, cooled before recovery occurs.
- The recovery equipment shall be in good working order with a set of instructions concerning the equipment that is at hand and shall be suitable for the recovery of all appropriate refrigerants including, when applicable, flammable refrigerants. In addition, a set of calibrated weighing scales shall be available and in good working order. Hoses shall be complete with leak-free disconnect couplings and in good condition. Before using the recovery machine, check that it is in satisfactory working order, has been properly maintained and that any associated electrical components are sealed to prevent ignition in the event of a refrigerant release. Consult manufacturer if in doubt.
- The recovered refrigerant shall be returned to the refrigerant supplier in the correct recovery cylinder, and the relevant waste transfer note arranged. Do not mix refrigerants in recovery units and especially not in cylinders.
- If compressors or compressor oils are to be removed, ensure that they have been evacuated to an acceptable level to make certain that flammable refrigerant does not remain within the lubricant. The evacuation process shall be carried out prior to returning the compressor to the suppliers. Only electric heating to the compressor body shall be employed to accelerate this process. When oil is drained from a system, it shall be carried out safely.
- In addition to conventional charging procedures, the following requirements shall be followed:
  - Ensure that contamination of different refrigerants does not occur when using charging equipment. Hoses or lines shall be as short as possible to minimize the amount of refrigerant contained in them.
  - Cylinders shall be kept in an appropriate position according to the instructions.
  - Ensure that the refrigerating system is earthed (grounded) prior to charging the system with refrigerant.
  - Label the system when charging is complete (if not already).
  - Extreme care shall be taken not to overfill the refrigerating system.

## **⚠ DANGER continued**

- Prior to recharging the system, it shall be pressure-tested with the appropriate purging gas. The system shall be leak-tested on completion of charging but prior to commissioning. A follow up leak test shall be carried out prior to leaving the site.
- Repair and maintenance to electrical components shall include initial safety checks and component inspection procedures. If a fault exists that could compromise safety, then no electrical supply shall be connected to the circuit until it is satisfactorily dealt with. If the fault cannot be corrected immediately but it is necessary to continue operation, an adequate temporary solution shall be used. This shall be reported to the owner of the equipment, so all parties are advised.
- Confirm that capacitors are discharged: this shall be done in a safe manner to avoid possibility of sparking.
- Confirm that no live electrical components and wiring are exposed while charging, recovering, or purging the system.
- Confirm that there is continuity of earth bonding (grounding).
- During repairs to sealed components, all electrical supplies shall be disconnected from the equipment being worked upon prior to any removal of sealed covers, etc. If it is absolutely necessary to have an electrical supply to equipment during servicing, then a permanently operating form of leak detection shall be located at the most critical point to warn of a potentially hazardous situation.
- Where electrical components are being changed, they shall be fit for the purpose and to the correct specification. At all times, Hoshizaki America's maintenance and service guidelines shall be followed. If in doubt, consult Hoshizaki America's Technical Support department for assistance.
- Confirm the actual refrigerant charge is in accordance with the room size within which the refrigerant containing parts are installed.
- Confirm the ventilation machinery and outlets are operating adequately and are not obstructed.
- Confirm marking to the equipment continues to be visible and legible. Markings and signs that are illegible shall be corrected.
- Confirm refrigerating pipe or components are installed in a position where they are unlikely to be exposed to any substance which may corrode refrigerant containing components, unless the components are constructed of materials which are inherently resistant to being corroded or are suitably protected against being so corroded.
- Particular attention shall be paid to the following to ensure that by working on electrical components, the casing is not altered in such a way that the level of protection is affected. This shall include damage to cables, excessive number of connections, terminals not made to original specification, damage to seals, incorrect fitting of glands, etc.
- Ensure that the apparatus (control box/component) is mounted securely.

**⚠ DANGER continued**

- Ensure that seals or sealing materials have not degraded to the point that they no longer serve the purpose of preventing the ingress of flammable atmospheres. Replacement parts shall be in accordance with Hoshizaki America's specifications.
- Do not apply any permanent inductive or capacitance loads to the circuit without ensuring that this will not exceed the permissible voltage and current permitted for the equipment in use.
- Intrinsically safe components are the only types that can be worked on while live in the presence of a flammable atmosphere. The test apparatus shall be at the correct rating.
- Replace components only with parts specified by Hoshizaki America. Other parts can result in the ignition of refrigerant in the atmosphere from a leak.
- Check that cabling will not be subject to wear, corrosion, excessive pressure, vibration, sharp edges, or any other adverse environmental effects. The check shall also take into account the effects of aging or continual vibration from sources such as compressors or fans.

## 2. Français



### R-290 Classe A3 Réfrigérant Inflammable Utilisé

#### **⚠ DANGER**

#### **Risque De Feu Ou D'Explosion. Fluide Frigorigène Inflammable Utilisé.**

- Assurez-vous de suivre toutes les informations importantes de sécurité situées au début de ce manuel et dans cette section.
- L'appareil ne doit être diagnostiqué et réparé que par un personnel qualifié afin de prévenir les risques de mort, d'électrocution, de blessures graves ou d'incendie.
- L'entretien doit être effectué par du personnel formé et certifié pour la manipulation de réfrigérants inflammables afin de réduire au minimum le risque d'inflammation dû à des pièces incorrectes ou à un entretien inadéquat.
- Suivez attentivement les instructions de manutention conformément aux règlements nationaux.
- Ne pas utiliser de dispositifs mécaniques ou d'autres moyens pour accélérer le processus de dégivrage ou pour nettoyer, autres que ceux recommandés par le fabricant.
- Attention, les fluides frigorigènes peuvent ne pas dégager d'odeur.
- Ne pas perforer la tubulure contenant le frigorigène. Risque de feu ou d'explosion si la tubulure contenant le frigorigène est perforée; suivre les instructions de manutention avec soin.
- Les pièces doivent être remplacées par des pièces similaires, de manière à réduire au minimum le risque d'inflammation dû à des pièces incorrectes.
- Ne placez aucune source d'inflammation potentielle dans ou près de l'appareil.
- Avant de commencer à travailler sur des systèmes contenant des réfrigérants inflammables, des contrôles de sécurité sont nécessaires pour s'assurer que le risque d'inflammation est minimisé.
- Tout le personnel d'entretien et les autres personnes travaillant dans la zone locale doivent être informés de la nature des travaux effectués. Les travaux dans des espaces confinés doivent être évités.
- Les travaux doivent être entrepris selon une procédure contrôlée afin de minimiser le risque de présence de gaz ou de vapeur inflammable pendant l'exécution des travaux.
- La zone doit être contrôlée à l'aide d'un détecteur de réfrigérant approprié avant et pendant les travaux, afin de s'assurer que le technicien est conscient de l'existence d'atmosphères potentiellement toxiques ou inflammables.
- Assurez-vous que l'équipement de détection des fuites utilisé est adapté à l'utilisation de tous les réfrigérants applicables, c'est-à-dire qu'il ne produit pas d'étincelles, qu'il est correctement scellé ou qu'il est intrinsèquement sûr. REMARQUE: L'utilisation de mastic silicone peut réduire l'efficacité de certains types d'équipements de détection des fuites.

## **⚠ DANGER Continué**

- En aucun cas, des sources potentielles d'inflammation ne doivent être utilisées pour rechercher ou détecter des fuites de réfrigérant. Une lampe haloïde (ou tout autre détecteur utilisant une flamme nue) ne doit pas être utilisée.
- Les méthodes de détection de fuite suivantes sont considérées comme acceptables pour tous les systèmes de réfrigération:
  - Des détecteurs de fuites électroniques peuvent être utilisés pour détecter les fuites de réfrigérants, mais, dans le cas de réfrigérants inflammables, la sensibilité pourrait ne pas être adéquate ou nécessiter un réétalonnage. (L'équipement de détection doit être étalonné dans une zone sans réfrigérant.) Assurez-vous que le détecteur n'est pas une source potentielle d'inflammation et qu'il est adapté au réfrigérant utilisé. L'équipement de détection des fuites doit être réglé sur un pourcentage de la LII du réfrigérant et doit être étalonné en fonction du réfrigérant utilisé, et le pourcentage approprié de gaz (25% au maximum) est confirmé.
  - Les liquides de détection des fuites conviennent également à la plupart des réfrigérants, mais l'utilisation de détergents contenant du chlore doit être évitée, car le chlore peut réagir avec le réfrigérant et corroder la tuyauterie en cuivre.  
Remarque : Voici quelques exemples de liquides de détection de fuites :
    - méthode des bulles
    - agents de méthode fluorescents
- Si un travail à chaud doit être effectué sur l'équipement réfrigérant ou toute partie associée, un équipement d'extinction d'incendie approprié doit être disponible. Un extincteur à poudre chimique ou à CO<sub>2</sub> devrait être installé à proximité de la zone de chargement. Un extincteur chimique de classe B doit être disponible à tout moment.
- Il est interdit à toute personne effectuant des travaux en rapport avec un système réfrigérant qui impliquent la mise à nu d'une tuyauterie d'utiliser des sources d'inflammation de manière à entraîner un risque d'incendie ou d'explosion. Toutes les sources d'inflammation possibles, y compris la cigarette, doivent être suffisamment éloignées du site d'installation, de réparation, d'enlèvement et d'élimination, au cours desquels du réfrigérant peut éventuellement être libéré dans l'espace environnant. Avant d'entamer les travaux, la zone autour de l'équipement doit être étudiée pour s'assurer qu'il n'y a aucun risque d'inflammabilité ou d'inflammation. Des panneaux « Interdiction de fumer » doivent être affichés.
- Assurez-vous que la zone est à l'air libre ou qu'elle est correctement ventilée avant de pénétrer dans le système ou d'effectuer un travail à chaud. Un certain degré de ventilation doit être maintenu pendant la période où les travaux sont effectués. La ventilation doit permettre de disperser en toute sécurité tout réfrigérant libéré et, de préférence, de l'expulser dans l'atmosphère.

## **⚠ DANGER Continué**

- Pour pénétrer dans le circuit du réfrigérant afin d'effectuer des réparations ou pour toute autre raison, des procédures conventionnelles doivent être utilisées. Toutefois, pour les réfrigérants inflammables, il est important de suivre les meilleures pratiques, car l'inflammabilité est un facteur à prendre en considération. La procédure suivante doit être respectée:
  - éliminer le réfrigérant en toute sécurité conformément aux réglementations locales et nationales
  - purger le circuit avec du gaz inerte
  - évacuer (en option pour A2L)
  - purger avec du gaz inerte (en option pour A2L)
  - ouvrir le circuit par coupure ou brasage
- Si une fuite est suspectée, toutes les flammes nues doivent être enlevées/éteintes.
- Si une fuite de réfrigérant nécessitant un brasage est constatée, tout le réfrigérant doit être récupéré dans le système ou isolé (au moyen de vannes d'arrêt) dans une partie du système éloignée de la fuite.
- Lors de l'élimination du réfrigérant d'un système, que ce soit pour l'entretien ou la mise hors service, il est recommandé de veiller à ce que tous les réfrigérants soient éliminés en toute sécurité.
- Lors du transfert de réfrigérant dans des bouteilles, veillez à ce que seules des bouteilles de récupération de réfrigérant appropriées soient utilisées. Assurez-vous que le nombre de bouteilles nécessaires pour contenir la charge totale du système est disponible. Toutes les bouteilles à utiliser sont désignées pour le réfrigérant récupéré et étiquetées pour ce réfrigérant (c'est-à-dire des bouteilles spéciales pour la récupération du réfrigérant). Les bouteilles doivent être équipées d'une soupape de surpression et de soupapes d'arrêt associées qui sont en bon état de fonctionnement. Les bouteilles de récupération vides sont évacuées et, si possible, refroidies avant la récupération.
- L'équipement de récupération doit être en bon état de fonctionnement, accompagné d'un ensemble d'instructions concernant l'équipement disponible et doit être adapté à la récupération de tous les réfrigérants appropriés, y compris, le cas échéant, les réfrigérants inflammables. En outre, un ensemble de balances étalonnées doit être disponible et en bon état de fonctionnement. Les tuyaux doivent être complets, équipés de raccords de déconnexion sans fuite et en bon état. Avant d'utiliser la machine de récupération, vérifiez qu'elle est en bon état de fonctionnement, qu'elle a été correctement entretenue et que tous les composants électriques associés sont scellés pour éviter toute inflammation en cas de fuite de réfrigérant. Consulter le fabricant en cas de doute.
- Le réfrigérant récupéré doit être renvoyé au fournisseur de réfrigérant dans la bouteille de récupération appropriée et le bon de transfert de déchets correspondant doit être établi. Ne mélangez pas les réfrigérants dans les unités de récupération et surtout pas dans les bouteilles.

## **⚠ DANGER Continué**

- Si les compresseurs ou les huiles de compresseur doivent être retirés, assurez-vous qu'ils ont été évacués à un niveau acceptable afin de s'assurer qu'il ne reste pas de réfrigérant inflammable dans le lubrifiant. Le processus d'évacuation doit être effectué avant que le compresseur ne soit renvoyé aux fournisseurs. Seul le chauffage électrique du boîtier du compresseur doit être utilisé pour accélérer ce processus. Lorsque l'huile est vidangée d'un système, cette opération doit être effectuée en toute sécurité.
- En plus des procédures de charge conventionnelles, les exigences suivantes doivent être respectées:
  - S'assurer qu'aucune contamination de différents réfrigérants ne se produit lors de l'utilisation de l'équipement de charge. Les tuyaux ou conduites doivent être aussi courts que possible afin de minimiser la quantité de réfrigérant qu'ils contiennent.
  - Les bouteilles doivent être maintenues dans une position appropriée conformément aux instructions.
  - S'assurer que le système de réfrigération soit mis à la terre avant de charger le système avec du réfrigérant.
  - Étiqueter le système lorsque la charge est terminée (si cela n'a pas déjà été fait).
  - Il faut veiller à ne pas trop remplir le système de réfrigération.
- Avant de recharger le système, celui-ci doit être testé sous pression avec le gaz de purge approprié. Le système doit être soumis à un essai de fuite à la fin de la charge, mais avant la mise en service. Un test de contrôle de fuite doit être effectué avant de quitter le site.
- La réparation et l'entretien des composants électriques incluent les contrôles de sécurité initiaux et les procédures d'inspection des composants. En cas de défaut susceptible de compromettre la sécurité, aucune alimentation électrique ne doit être connectée au circuit tant que le problème n'a pas été résolu de manière satisfaisante. Si le défaut ne peut être corrigé immédiatement mais qu'il est nécessaire de poursuivre l'exploitation, une solution temporaire adéquate doit être utilisée. Cela doit être signalé au propriétaire de l'équipement, afin que toutes les parties soient informées.
- S'assurer que les condensateurs sont déchargés : cette opération doit être effectuée en toute sécurité afin d'éviter tout risque d'étincelle.
- S'assurer qu'aucun composant ou câblage électrique sous tension n'est exposé lors de la charge, de la récupération ou de la purge du système.
- S'assurer de la continuité de la mise à la terre.
- Lors des réparations de composants scellés, toutes les alimentations électriques doivent être déconnectées de l'équipement sur lequel on travaille avant tout retrait des couvercles scellés, etc. Si l'alimentation électrique de l'équipement est absolument nécessaire pendant l'entretien, un dispositif de détection des fuites fonctionnant en permanence doit être placé au point le plus critique afin de signaler en cas de situation potentiellement dangereuse.

## **⚠ DANGER Continué**

- Lorsque des composants électriques sont remplacés, ils doivent être adaptés à l'usage prévu et répondre aux spécifications correctes. Les directives de maintenance et d'entretien de Hoshizaki America doivent être respectées à tout moment. En cas de doute, consulter le service d'assistance technique de Hoshizaki America pour obtenir de l'aide.
- S'assurer que la charge réelle de réfrigérant est conforme à la taille de la pièce dans laquelle les pièces contenant du réfrigérant sont installées.
- S'assurer que les dispositifs et les sorties de ventilation fonctionnent correctement et ne sont pas obstrués.
- S'assurer que le marquage de l'équipement est toujours visible et lisible. Les indications et les panneaux illisibles doivent être corrigés.
- S'assurer que les tuyaux ou les composants de réfrigération sont installés dans un endroit où ils ne risquent pas d'être exposés à une substance susceptible de corroder les composants contenant du réfrigérant, à moins que les composants ne soient construits avec des matériaux intrinsèquement résistants à la corrosion ou qu'ils ne soient protégés de manière appropriée contre la corrosion.
- Une attention particulière doit être accordée aux points suivants afin de s'assurer qu'en travaillant sur les composants électriques, le boîtier n'est pas altéré de manière à ce que le niveau de protection soit affecté. Il s'agit notamment des dommages causés aux câbles, du nombre excessif de connexions, des terminaux non conformes aux spécifications d'origine, des dommages causés aux joints et du montage incorrect des presse-étoupes, etc.
- S'assurer que l'appareil (boîtier de commande/composant) est solidement fixé.
- S'assurer que les joints ou les matériaux d'étanchéité ne sont pas dégradés au point de ne plus pouvoir empêcher la pénétration d'atmosphères inflammables. Les pièces de rechange doivent être conformes aux spécifications de Hoshizaki America.
- N'appliquez aucune charge inductive ou capacitive permanente au circuit sans vous assurer que celle-ci ne dépassera pas la tension et le courant autorisés pour l'équipement utilisé.
- Les composants à sécurité intrinsèque sont les seuls types de composants sur lesquels il est possible de travailler sous tension en présence d'une atmosphère inflammable. L'appareil d'essai doit être adapté à la puissance requise.
- Ne remplacer les composants que par des pièces spécifiées par Hoshizaki America. D'autres pièces peuvent entraîner l'inflammation du réfrigérant dans l'atmosphère à la suite d'une fuite.
- Vérifier que le câblage ne sera pas soumis à l'usure, à la corrosion, à une pression excessive, à des vibrations, à des arêtes vives ou à tout autre effet environnemental négatif. Le contrôle doit également prendre en compte les effets du vieillissement ou des vibrations continues provenant de sources telles que les compresseurs ou les ventilateurs.

## B. Service Diagnosis



### R-290 Class A3 Flammable Refrigerant Used

#### **⚠ DANGER**

##### **Risk of Fire or Explosion. Flammable Refrigerant Used.**

- Be sure to follow all Important Safety Information located at the beginning of this manual and at the beginning of section "III.A. Safety Precautions When Servicing."
- Servicing shall be done by trained service personnel with certified competence in handling flammable refrigerants to minimize the risk of possible ignition due to incorrect parts or improper service.

##### **Risque De Feu Ou D'Explosion. Fluide Frigorigène Inflammable Utilisé.**

- Assurez-vous de suivre toutes les informations importantes de sécurité qui se trouvent au début du présent manuel et au début de la section «III.A. Précautions de sécurité lors de l'entretien.»
- L'entretien doit être effectué par du personnel formé et certifié pour la manipulation de réfrigérants inflammables afin de réduire au minimum le risque d'inflammation dû à des pièces incorrectes ou à un entretien inadéquat.

#### **⚠ WARNING**

- Risk of electric shock. Use extreme caution and exercise safe electrical practices.
- Risk of electric shock. Control switch in "OFF" position does not de-energize all loads (optional drain pump).
- Move the control switch to the "OFF" position, then turn off the power supply before servicing. Lockout/Tagout to prevent the power supply from being turned back on inadvertently.
- Moving parts (e.g., fan blade) can crush and cut. Keep hands clear.
- **CHOKING HAZARD:** Ensure all components, fasteners, and thumbscrews are securely in place after the appliance is serviced. Make sure that none have fallen into the ice storage bin.
- Make sure all food zones in the appliance are clean after service.

#### **⚠ DANGER**

Models utilizing R-290 refrigerant should only be used on a dispenser unit/ ice storage bin without electrical components or one designed to be used with flammable refrigerants. See the nameplate for the refrigerant type in your model.

## 1. Diagnostic Procedure

The diagnostic procedure is a sequence check that allows you to diagnose the electrical system and components. Before proceeding, check for correct installation, proper voltage per nameplate, and adequate water supply. Check CB using the steps in "III.B.5. Control Board Check." Check dip switch settings to assure that S4 dip switches and S5 dip switches 1 through 5 are in the factory default position. S4 dip switch 1, 2, 3, 4, and 5 are cleaning adjustments and the settings are flexible. For factory default settings, see "III.B.14.a) Default Dip Switch Settings."

Note: • **MT Check** - The neutral (W) is provided through through the MT. To confirm a good neutral, check for 60VAC from white (W) neutral to ground (GND). If 60VAC is present, neutral is good. If 60VAC is not present, check 208-230VAC main power supply to MT. If 208-230VAC is present, check MT continuity.

- When checking high voltage (115VAC), always choose a white (W) neutral wire to establish a good neutral connection.
- When checking voltage from the CB K1 connector (10 pin connector), pull CB K1 connector out slightly to allow room for multimeter test leads contact.

- 1) Turn off the power supply, then access the control box. Move the control switch to the "OFF" position. Clear any ice from BC.
- 2) Check that the 115VAC 10A fuse is good.

## 2. Sequence and Component Diagnosis

- 3) **Power On:** Turn on the power supply, then move the control switch to the "ICE" position. A 5-sec. delay occurs. CB red "POWER OK" LED and green "BC CLOSED" LED turn on. If yellow "BC OPEN" LED is on (indicating a full bin), check BC. Move ice away from BC actuator paddle. If yellow "BC OPEN" LED stays on, see "II.E. Bin Control Check."

Note: • CB red "POWER OK" LED remains on unless the 10.5VAC power supply is interrupted (K2 connector).

- Check CB using the steps in "II.D.Control Board Check."
- Confirm CB green "BC CLOSED" LED is on. If CB yellow "BC OPEN" LED is on, remove ice from BC. If no ice is around BC and yellow "BC OPEN" LED is on, see "II.E. Bin Control Check."

- a) **Power On Diagnosis:** If CB red "POWER OK" LED is off, confirm 10A fuse is good. Check for 115VAC at control switch #2 (BR) to neutral (W) then at control switch #1 (P) to neutral (W). If 115VAC is present on #2 (BR) and not on #1 (P), replace control switch. If 115VAC is present on control switch #1 (P), check for 115VAC at HPS (P) to neutral (W) then HPS (BK) to neutral (W). If 115VAC is present at HPS (P) and not at HPS (BK), HPS is open. See HPS Diagnosis below. If 115VAC is present at HPS (BK), check for 10.5VAC at CB K2 #1 red wire to CB K2 #2 red wire. If 10.5VAC is not present, check that the cleaning valve interlock switch is closed. Next, check CT continuity. If open, replace CT.

b) **HPS Diagnosis:** Confirm condenser coil is not clogged or restricted. Let refrigeration circuit pressures equalize. If HPS does not reset and pressures are equalized, replace HPS. If pressures are not equalized, reclaim refrigerant and diagnose refrigeration circuit restriction. Check that there are no restrictions in the refrigeration circuit.

Harvest Cycle: HGV, strainer, or check valve.

Freeze Cycle: FM, FMR, TXV, HM, LLV, WRV, strainer, check valve, drier, damaged line set or fitting, and fan blade for binding.

Confirm that the location meets installation requirements. See the appliance's instruction manual for details.

4) **1-Min. Fill Cycle – LED 4 is on.** WV energizes. After 1 min., CB checks for a closed FS. If FS is closed, the harvest cycle begins. If harvest cycle begins (Comp and HGV energize), continue to step 5a. If FS is open, WV remains energized until FS closes (low water safety protection during initial start up and at the end of each harvest).

**Diagnosis:** Check that water enters the water tank. If not, check that the water supply line shut-off valve is open and screens or external filters are clear. Check for 115VAC at CB K1 #6 (O) to neutral (W). If 115VAC is not present, replace CB. If 115VAC is present, and WV does not energize, check for 115VAC at WV. If 115VAC is present, check coil continuity. If open, replace WV. If the water tank fills, but the appliance fails to start harvest (Comp energized), check for open FS. See "II.F. Float Switch Check and Cleaning." If FS is closed and CB fails to start the harvest cycle after 1 min., replace CB.

5a) **Initial Harvest Cycle – LEDs 1, 4, and 2 are on.** WV continues. Comp and HGV energize. CB monitors the warming of the evaporator via the thermistor located on the suction line. When the thermistor reaches 48°F (9°C), CB reads 3.9 kΩ from the thermistor and turns harvest termination over to the harvest timer (S4 dip switch 1 & 2 and S5 dip switch 4). WV energized during harvest for a maximum of 6 min. or the length of harvest minus HPT setting (S4 dip switch 6), whichever is shorter. See step 5b below.

a) **Comp Diagnosis:** Check that evaporator is warming. If not, confirm that Comp energizes. If not, check for 115VAC at CB K1 #9 (Y) to neutral (W). If 115VAC is not present, check for 115VAC at CB K1 #10 (BK) to neutral (W). If 115VAC is present at #10 (BK) and not at #9 (Y), replace CB. If 115VAC is present, check for 115VAC at mode switch #2 (Y) to neutral and mode switch #1 (V) to neutral. If 115VAC is present at #2 (Y) and not at #1 (V), confirm mode switch is in "ICE" position. If in "ICE" position, check mode switch continuity. If open, replace mode switch. If 115VAC is present at mode switch #1 (V), check for 115VAC at CR solenoid. If 115VAC is present, confirm contacts are closed. If not, replace CR. If CR contacts are closed, check Comp external overload, Comp start and run capacitors, Comp start relay, and Comp motor winding.

- b) **HGV Diagnosis:** If Comp is energized and evaporator is not warming, check that HGV energizes and opens. Check for 115VAC at CB K1 #2 (P) to neutral (W). If 115VAC is not present and LED 2 is on, replace CB. If 115VAC is present, check for 115VAC at HGV coil and check HGV coil continuity. Replace as needed.
- c) **LLV Diagnosis:** Confirm that LLV is de-energized and closed (not bypassing). If energized, replace CB. If de-energized and bypassing, replace LLV.

5b) **Harvest Pump Time (Harvest Assist) – LEDs 1, 3, and 2 are on.** When the thermistor reaches 48°F (9°C), CB reads 3.9 kΩ from the thermistor and turns harvest termination over to the harvest timer (S4 dip switch 1 & 2 and S5 dip switch 4). When WV de-energizes, LED 4 turns off and LED 3 turns on. PM energizes. Comp and HGV continue.

**Diagnosis:** Place a thermometer on the suction line next to the thermistor. Has it warmed to 48°F (9°C) or warmer? Confirm thermistor status. See "III.B.7. Thermistor Check." If the thermistor reading is in proper range, dip switch 7 is on, and PM does not energize before harvest terminates, replace CB. If WV continues, check for 115VAC at CB K1 #6 (O). If 115VAC is present, and LED 4 is off, replace CB. If LED 3 is on and PM is not energized, check for 115VAC at CB K1 #5 (W/BU). If 115VAC is not present, replace CB. If 115VAC is present and PM is not energized, check PM capacitor and motor winding continuity.

5c) **Initial Harvest Cycle Termination Diagnosis:** When the thermistor reaches 48°F (9°C), CB reads 3.9 kΩ from the thermistor and turns harvest termination over to the harvest timer (S4 dip switch 1 & 2 and S5 dip switch 4). Check discharge line temperature. For a thermistor check, see "III.B.7. Thermistor Check." If 1-min. fill cycle starts after harvest timer terminates, check that FS is clean and operating properly, see "III.B.6. Float Switch Check and Cleaning." If FS is closed, CB proceeds to the next cycle. If not, replace CB.

Note: The minimum total time allowed by CB for a complete harvest cycle is based on S5 dip switch 4. Maximum harvest time allowed is 20 min.

**NOTICE! S4 dip switch 7 must remain on. Otherwise, PM will not energize during the last seconds of harvest.**

6) **Freeze Cycle – LED 1 is on.** Comp and PM continue. FM and LLV energize. HGV de-energizes. Appliance is held in freeze by a 5-min. short cycle protection timer. After 5-min. short cycle protection timer terminates and FS opens, freeze cycle terminates.

Note: PM power supply continues from CB K1 #4 (W/BU) in harvest and in freeze.

**Anti-Slush:** When anti-slush is enabled (S5 dip switch 5 "ON"), PM de-energizes when thermistor reaches 36°F (2.2°C) (5.8kΩ) for 10 sec. then, energizes for the remainder of the freeze cycle.

a) **Freeze Cycle Diagnosis:** Confirm Comp and PM continue. Confirm that FM and LLV energize. Next, confirm HGV de-energized. During the first 5 min. of freeze, confirm evaporator is cooling. If not, confirm WV de-energized (not leaking by), HGV de-energized (not bypassing), LLV and FM energize, TXV operates correctly, Comp is efficient, and refrigerant charge is correct. See "VII.A. Specification and Performance Data."

- b) **Comp Diagnosis:** If Comp and FM de-energize once freeze begins, check that appliance has not shut off on HPS ("POWER OK" LED off). If so, check "III.B.2.3) b) HPS Diagnosis" above. If "POWER OK" LED is on, check for 115VAC at CB K1 #9 (Y) to neutral (W). If 115VAC is not present and Comp LED is on, replace CB. If 115VAC is present, check for 115VAC at CR coil. If 115VAC is present, check CR coil and contact continuity. Replace as needed. If CR is okay, check Comp start relay and start and run capacitors. Next, check Comp motor winding continuity. If Comp is energized but evaporator is not cooling, check for an inefficient Comp. See "VII.A. Specification and Performance Data Sheets."
- c) **WV and HGV Diagnosis:** If WV is energized, check for 115VAC at CB K1 #6 (O) to neutral (W). If 115VAC is present after PM energizes in harvest cycle, replace CB. If 115VAC is not present, replace WV (bypassing). If HGV did not de-energize at the end of harvest, check for 115VAC at CB K1 #2 (P) to neutral (W). If 115VAC is present at CB K1 #2 (P) and FM/HGV LED is off, replace CB. If 115VAC is not present at CB K1 #2 (P), replace HGV (bypassing).
- d) **PM Diagnosis:** Confirm water is flowing over evaporator from PM and not WV. If PM de-energizes once freeze begins, check for 115VAC at CB K1 #4 (W/BU) to neutral (W). If 115VAC is not present, replace CB. If 115VAC is present and PM is de-energized, check PM capacitor and motor winding continuity.
- e) **FM and LLV Diagnosis:** If FM or LLV does not energize, check for 115VAC at CB K1 #3 (BK) to neutral (W). If 115VAC is not present and FM/HGV LED is off, check for 115VAC at CB K1 #1 (V). If 115VAC is present at #1 (V) and not at #3 (BK), replace CB. If 115VAC is present at #3 (BK) and FM/HGV LED is off:  
For FM, check capacitor, motor winding, and blade for binding.  
For LLV, check coil voltage and continuity.  
Note: FM is OFF when FM/HGV LED is on.
- f) **Refrigerant Pressures, and TXV Diagnosis:** If evaporator is still not cooling, check refrigerant pressures. See "VII.A. Specification and Performance Data Sheets." Next, check TXV for proper operation. Remove TXV bulb and hold it in your hand, refrigerant low-side pressure should rise, place TXV bulb in ice water, refrigerant low-side pressure should drop. A 10 to 15 pound pressure swing between warm and cold conditions indicate a good TXV. If a 10 to 15 pound swing is not present, replace TXV.
- g) **Freeze Termination Diagnosis:** After 5 min. in freeze, disconnect CB K5 FS connector. 15 sec. later appliance should switch out of the freeze cycle (15 second delay after FS opens before terminating the freeze cycle). If appliance remains in freeze longer than 15 sec. after FS removed, replace CB. If appliance switches with FS removed but would previously not switch out of freeze with FS connected (long freeze - 3 beep alarm), see "III.B.6. Float Switch Check and Cleaning."

Note: Normal freeze cycle will last 20 to 40 min. depending on model and conditions. Cycle times and pressures should follow performance data provided in this manual. See "VII.A. Specification and Performance Data Sheets."

i) **Short Freeze Cycle Diagnosis:** Confirm water tank fills and overflows during fill and harvest cycles. If not, check water supply filters, shut-off valve, WV screen. If water tank empties before 5 min. timer terminates and freeze cycle is short, check that CV is not leaking by (water flowing down the potable drain). If CV is leaking by, remove and clean CV, replace rubber seat and spring if necessary. If water tank is full, see "III.B.6. Float Switch Check and Cleaning." for erratic FS.

7) **Pump-Out Cycle – LEDs 1, 3, and 2 are on (10/20 second pump-out).** Timing of the first pump-out is determined by S4 dip switch 5. See the table below.

Control Board Settings		
S4 Dip Switch Setting	Pump-Out Frequency	1st Pump-Out
No. 5		
OFF	Every 10 cycles	After 11th freeze cycle
ON	Every cycle	After 2nd freeze cycle

Comp continues, HGV energizes.

Note: If S4 dip switch 3 & 4 are set to 3 off and 4 on, WV LED turns on and WV energizes. **NOTICE! S5 dip switch 1 must not be adjusted. This is the pump-out circulation selection and allows DV to energize in pump-out.**

FM and LLV de-energize. PM stops for 2 sec., then PM and DV energize for 10/20 sec. depending on pump-out timer (S4 dip switch 3 & 4) setting. When the pump-out timer terminates, pump-out is complete. The pump-out frequency control (S4 dip switch 5) is factory set, and generally no adjustment is required. However, the pump-out frequency control can be set to have a pump-out occur every 10 cycles or every cycle. For details, see "III.B.14.d) Pump-Out Frequency Control (S4 dip switch 5)."

a) **Pump-Out Diagnosis:** In the freeze cycle before pump-out (see table above), after 5 min. of freeze disconnect CB black K5 connector (FS connector). Check that PM stops and re-starts. Next, check that PM and DV energized (water flowing down the drain through DV). If PM does not stop and re-start, check that CB Comp, PM, and DV LEDs are on. If not, replace CB. If Comp, PM, and DV LEDs are on and PM does not energize, check for 115VAC at CB K1 #4 (R) to neutral (W). If 115VAC is not present, replace CB. If not, check PM motor windings and impeller for binding. If energized, make sure DV energized. If not, check for 115VAC at CB K1 #5 (W/BU). If 115VAC is not present and DV LED is on, replace CB. If 115VAC is present, check DV solenoid continuity. Replace as needed. If DV is energized and open, check that the drain line is not clogged. Confirm FM and LLV de-energize. If FM or LLV are energized with Comp, PM, and DV LEDs on, replace CB.

8) **Normal Harvest Cycle** – Same as the initial harvest cycle. Return to step 5a) above.

Note: Appliance continues to cycle until BC is satisfied or power is switched off.

The appliance always restarts at the 1-min. fill cycle.

## 2. Shutdown Diagnosis

- 1) See "II.B.5. Bin Control Check."

## 3. Freeze-Up Detection Cycle (FUD)

The freeze-up detection cycle (FUD) is enabled when the CB S5 DIP Switch 4 is in the "OFF" position. FUD monitoring starts in the 2nd freeze cycle after startup, 2nd freeze cycle after a bin control restart, 1st freeze cycle after a Modified Harvest, and every freeze cycle thereafter until the FUD cycle resets. The CB monitors the thermistor temperature and the time to reach 36°F (2°C) during the freeze cycle, to evaluate for any abnormal freeze cycle issues. When the FUD cycle is activated, the CB red "POWER" LED starts blinking and continues to blink throughout the FUD cycle. A FUD cycle consists of 1 modified harvest, 6 normal freeze cycles, and 5 normal harvest cycles. The FUD cycle terminates after achieving passing results at CB checks 1 and 2 on the 6th consecutive freeze cycle without a FUD cycle initiation. The red CB "POWER" LED returns to a solid state.

Note: If "POWER" LED is blinking and a manual reset is required, see "III.B.4.5)b) Manual Reset:" to reset FUD cycle.

### 1) FUD Cycle Initiation:

A FUD modified harvest cycle is initiated by one of the CB checks below:

- a) **Check 1:** Temperature/Time Initiation - Occurs in the 2nd freeze cycle after startup, the 2nd freeze cycle after a bin control restart, or the 1st freeze cycle after a Modified Harvest cycle and every freeze cycle thereafter. Thermistor reaches 36°F (2°C) within the first 30 sec. of freeze cycle initiation, FUD cycle initiates.
- b) **Check 2:** Temperature Time Initiation – Occurs in the 2nd freeze cycle after startup, the 2nd freeze cycle after a bin control restart, or the 3rd freeze cycle after a Modified Harvest cycle and every freeze cycle thereafter. Thermistor reaches 36°F (2°C) within the 31 to 90 seconds of freeze cycle initiation. CB then compares the time differential between the previous time from freeze cycle initiation to 36°F (2°C) and the current from freeze cycle initiation to 36°F (2°C). If the time differential is equal to or greater 40 sec. a FUD cycle is initiated.

Check 2 Initiation Example: If the previous time from freeze cycle initiation to 36°F (2°C) was 110 seconds and the current time from freeze cycle initiation to 36°F (2°C) is 60 seconds, the time differential is 50 sec. As this is greater than 40 sec., a FUD cycle is initiated.

Check 2 Non-initiation Example: If the previous time from freeze cycle initiation to 36°F (2°C) was 110 seconds and the current time from freeze cycle initiation to 36°F (2°C) is 80 seconds, the time differential is 30 sec. As this is less than the 40 sec., a FUD cycle is not initiated.

2) **FUD Cycle Modified Harvest – LEDs Comp, PM, WV, FM/HGV, are on and "POWER" LED Starts Blinking:**

A FUD modified harvest cycle is similar to a normal harvest cycle, with the following differences:

- **20-sec. PM:** PM LED on and PM energized for the first 20 seconds of the FUD cycle modified harvest. PM LED turns off and PM de-energizes after 20 sec.
- **6-min. WV:** WV LED on and WV energized for a mandatory 6-min. time frame during the FUD cycle modified harvest. WV LED turns off and WV de-energizes after 6 min.
- **100-sec. HPT:** PM LED on and PM energizes. HPT is now 100 sec. (Default is 50 sec. for normal harvest cycle). PM LED remains on and PM remains energized. HPT terminates and freeze cycle starts.

3) **FUD Cycle Freeze Cycle – LEDs Comp and PM are on and "POWER" LED Continues Blinking:**

During the 1st FUD freeze cycle, CB check 1 occurs. If 36°F (2°C) is detected within 30 sec., freeze cycle is terminated and a FUD modified harvest initiates. If the first freeze cycle CB check 1 passes, the freeze cycle continues until the FS terminates the freeze cycle (no CB check 2 during first freeze cycle after FUD modified harvest). The CB check 2 is delayed until the 2nd freeze cycle after a FUD cycle modified harvest. During the 2nd freeze cycle and every freeze cycle thereafter, both CB checks 1 and 2 occur. If either CB checks 1 or 2 fail, FUD Modified Harvest initiates.

4) **FUD Cycle Termination - "POWER" LED Stops Blinking:**

When the CB checks 1 and 2 have completed 6 consecutive freeze cycle checks with no FUD modified harvest initiation, the FUD cycle terminates. The CB red "POWER" LED resets and returns to a solid state. For Manual reset (if required), see "II.B.4.5)d) Manual Reset" to reset FUD cycle.

**FUD Cycle Diagnostics:**

- a) **20 sec. PM:** CB red "POWER" LED blinking. CB LEDs Comp, WV, PM, and FM/HGV are on and Comp, FM, HG, PM, and WV energize. 20-sec. PM timer starts. Once 20-sec. PM timer terminates, PM de-energizes and PM LED turns off. Comp, FM, FM/HGV, and WV continue.

**Diagnosis:** Confirm water is flowing over and into the evaporator from the PM and the PM LED is on.

Check for 115VAC at CB K1 #4 (R) to neutral (W). If 115VAC is not present and PM LED is on, replace CB. If 115VAC is present and PM is de-energized, check PM capacitor and motor winding continuity. Replace PM capacitor and/or PM if needed.

- b) **6-Min. WV:** CB red "POWER" LED blinking. CB LEDs Comp, WV, and FM/HGV are on and Comp, FM, HG, and WV are energized. 6-min. WV timer starts. When the 6-min. WV timer terminates, WV de-energizes. WV LED turns off.

**Diagnosis:** Confirm water is flowing into the evaporator from the WV and the WV LED is on. If WV LED stays on longer than 6 min. and WV is energized, check for 115VAC at CB K1 #6 (O) to neutral (W). If 115VAC is present, replace CB. If 115VAC is not present, replace WV (bypassing).

c) **Harvest Pump Time (Harvest Assist):** CB red "POWER" LED blinking. CB LEDs Comp, PM, and FM/HGV are on and Comp, FM, HGV, and PM remain energized. When the thermistor reaches 48°F (9°C), CB reads 3.9 kΩ from the thermistor and turns harvest termination over to the harvest pump timer. When WV de-energizes, WV LED turns off and PM LED turns on. PM energizes. Comp and HGV continue. **Diagnosis:** Place a thermometer on the suction line next to the thermistor. Has it warmed to 48°F (9°C) or warmer? Confirm thermistor status. See "III.B.8. Thermistor Check." If the thermistor reading is in proper range, dip switch 7 is on, PM LED is on, and PM has not energized before harvest terminates, check for 115VAC at CB K1 #4 (R). If 115VAC is not present, replace CB. If 115VAC is present, PM LED is on, and PM has not energized before harvest terminates, check PM capacitor and motor winding continuity. Replace PM capacitor and/or PM if needed. If WV continues, check for 115VAC at CB K1 #6 (O). If 115VAC is present, and WV LED is off, replace CB.

5) **FUD Modified Harvest Cycle Reset ("POWER" LED Stops Blinking):**

- a) **Freeze Cycle Reset:** The CB red "POWER" LED will continue to blink after a power cycle. The FUD cycle terminates after achieving passing results at CB checks 1 and 2 on the 6th consecutive freeze cycle without a FUD cycle initiation.
- b) **Manual Reset:** Switch CB S5 DIP switch #4 to the "ON" position, then back to the "OFF" position. CB resets to normal operating mode and CB red "POWER" LED stops blinking.

Legend: **BC**—bin control; **CB**—control board; **Comp**—compressor; **CR**—compressor relay; **CT**—control transformer; **CV**—check valve; **FM**—fan motor; **FMR**—fan motor remote; **FS**—float switch; **HGV**—hot gas valve; **HM**—headmaster (C.P.R.); **HPS**—high-pressure switch; **LLV**—liquid line valve; **PM**—pump motor; **TXV**—thermostatic expansion valve; **WRV**—water regulating valve; **WV**—inlet water valve

#### 4. Control Board Check

Before replacing CB that does not show a visible defect and that you suspect is bad, always conduct the following check procedure. This procedure will help you verify your diagnosis.

Alarm Reset: If CB is in alarm (beeping), press the "ALARM RESET" button on CB while CB is beeping. **WARNING! Risk of electric shock. Care should be taken not to touch live terminals.** Once reset, the icemaker starts at the 1-minute fill cycle. For audible alarm information, see "III.B.14. LED Lights and Audible Alarm Safeties."

- 1) Check the dip switch settings to assure that S4 dip switch 3, 4, 7, 8, 9, 10 and S5 dip switch 1 through 5 are in the factory default position. S4 dip switch 1, 2, 5, and 6 are cleaning adjustments and the settings are flexible. For factory default settings, see "III.B.15.a) Default Dip Switch Settings."
- 2) Move the control switch to the "ON" position and the mode switch to the "ICE" position. If the red CB "POWER" LED is on, control voltage is good, continue to step 3. If CB "POWER" LED is off, check CT secondary circuit. CT output is 10.5VAC at 115VAC primary input. If the secondary circuit has proper voltage and the red LED is off, replace CB.

If the secondary circuit does not have proper voltage, check CT primary circuit. Check for 115VAC at CB K1 connector pin #10 (BK) to neutral (W) for 115VAC. Always choose a white (W) neutral wire to establish a good neutral connection when checking voltages. For additional checks, see "III.B.11.a) No Ice Production."

- 3) The "OUTPUT TEST" button provides a relay sequence test. Make sure the control switch is in the "ON" position and the mode switch is in the "ICE" position, then press the "OUTPUT TEST" button. For the correct lighting sequence, see the table below. Note that the order of the LEDs from the outer edge of the control board is Comp, CV, WV, DV, PM, FM/HGV. Components cycle during the test. See Fig. 1. Following the output test cycle, the icemaker begins normal icemaking operation at the 1-minute fill cycle. If the LEDs do not light as described above, replace CB.

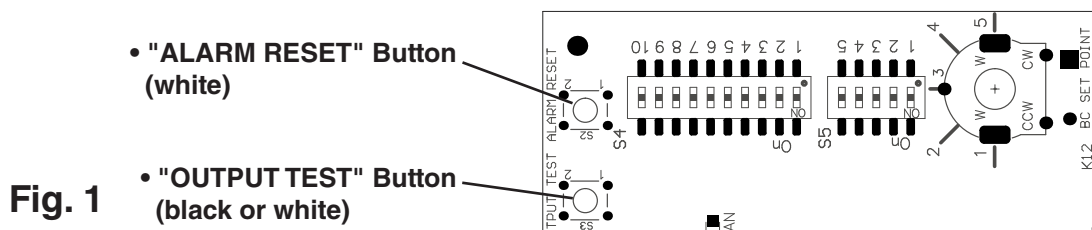

#### **IMPORTANT! Do not press the "OUTPUT TEST" button while CB is in alarm.**

See Fig. 1. Pressing the "OUTPUT TEST" button while CB is in alarm initiates an output test and locks out the "ALARM RESET" button until power is turned off and back on. If not, confirm BC status. See "II.E. Bin Control Check." If BC checks ok, replace CB.

- 4) To verify voltage output from CB to the components, slide the CB K1 connector out far enough to allow multimeter lead contact. With the icemaker in the cycle to be tested, check output voltage from the corresponding pin on CB K1 connector to a neutral (W) wire. If output voltage is not found and the appropriate LED is on, replace CB.
- 5) Check CB control connectors K3, K4, K5, and K12 for correct VDC per table below. See Fig. 2.

Legend: **BC**—bin control; **CB**—control board; **CT**—control transformer

K3 Thermistor	
Pin #	VDC
#1 to #2	5VDC
#1 to #3	5VDC
#2 to #3	0VDC

K5 Float Switch	
Pin #	VDC
#1 to #2	1.2VDC
#1 to #3	2VDC
#2 to #3	1.2VDC

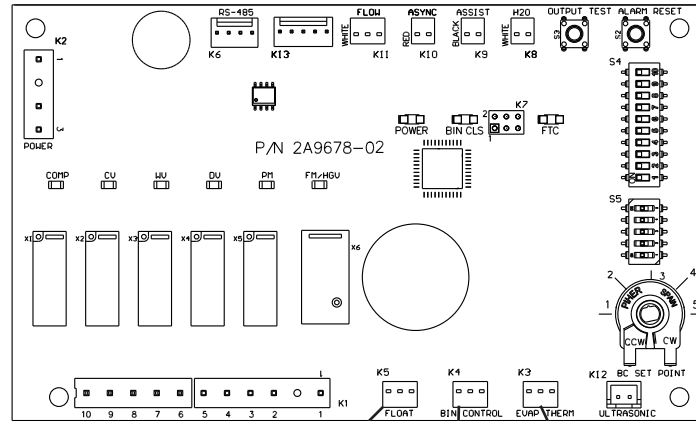

**Fig. 2** K5 Float Switch K4 Open K3 Thermistor

## 5. Bin Control Check

### a) Bin Control Check

A lever-actuated proximity switch is used to control the ice level in the storage bin.

No adjustment is required.

To check BC, follow the steps below.

- 1) Turn off the power supply.
- 2) Remove the front panel, then move the control switch to the "OFF" position.
- 3) Remove the control box cover, then clear any ice away from BC.
- 4) Check BC wire harness connections. See Fig. 1.
- 5) Disconnect BC connector from CB K4 connector.
- 6) Check for continuity across the wires of BC connector. When the actuator paddle is not engaged, BC switch is closed. If open, check that the wire harness connector is properly connected and that the actuator paddle is not sticking. Clean if necessary. See "II.E.b) Bin Control Cleaning." If BC switch still reads open, replace BC.
- 7) Press and hold the actuator paddle; check for continuity across the wires of BC connector. When the actuator paddle is engaged, BC switch is open. If closed, check that the actuator paddle is not restricted. Clean if necessary. See "II.E.b) Bin Control Cleaning." If BC switch still reads closed, replace BC.
- 8) Reconnect BC connector to CB K4 connector, then move the control switch to the "ICE" position. Turn on the power supply.
- 9) Check that CB green "BC CLOSED" LED is on.
- 10) Allow the icemaker to cycle on. Press and hold the actuator paddle. CB yellow "BC OPEN" LED should turn on and the icemaker should shut down according to the chart below. If it does not, replace CB.

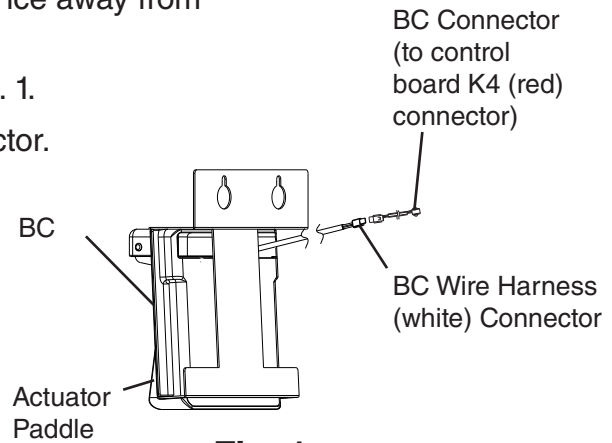

**Fig. 1**

Cycle at Bin Control Activation	Shutdown
Fill Cycle	15 sec. after activation.
Harvest Cycle	At the end of the harvest cycle, or up to 15 sec. into the freeze cycle if activated at the end of the harvest cycle.
Freeze Cycle	15 sec. after activation if activated at least 15 sec. before the 5-min. short cycle protection timer terminates. Otherwise, at the end of the next harvest cycle.

Legend: **BC**—bin control; **CB**—control board

### b) Bin Control Cleaning

Scale may build up on BC. Scale can cause the actuator paddle and magnet to stick. In this case, BC should be cleaned.

#### **⚠ WARNING**

**CHOKING HAZARD:** Ensure all components, fasteners, and thumbscrews are securely in place after the icemaker is serviced. Make sure that none have fallen into the dispense unit/ice storage bin.

- 1) Turn off the power supply.
- 2) Remove the front panel, then move the control switch to the "OFF" position.
- 3) Clear any ice away from BC.
- 4) Disconnect BC connector from CB K4 connector, then remove BC from the icemaker.
- 5) Remove the actuator paddle from the switch mount. See Fig. 2.
- 6) Wipe down BC with a mixture of 1 part of Hoshizaki "Scale Away" and 25 parts of warm water. Rinse the parts thoroughly with clean water.
- 7) Reassemble BC and replace it in its correct position.  
Note: If the magnet was removed for cleaning, be sure to replace it in its correct position.
- 8) Reconnect BC connector to CB K4 connector, then move the control switch to the "ICE" position.
- 9) Replace the control box cover in its correct position.
- 10) Turn on the power supply to start the automatic icemaking process.
- 11) Replace the front panel in its correct position.

Legend: **BC**—bin control; **CB**—control board

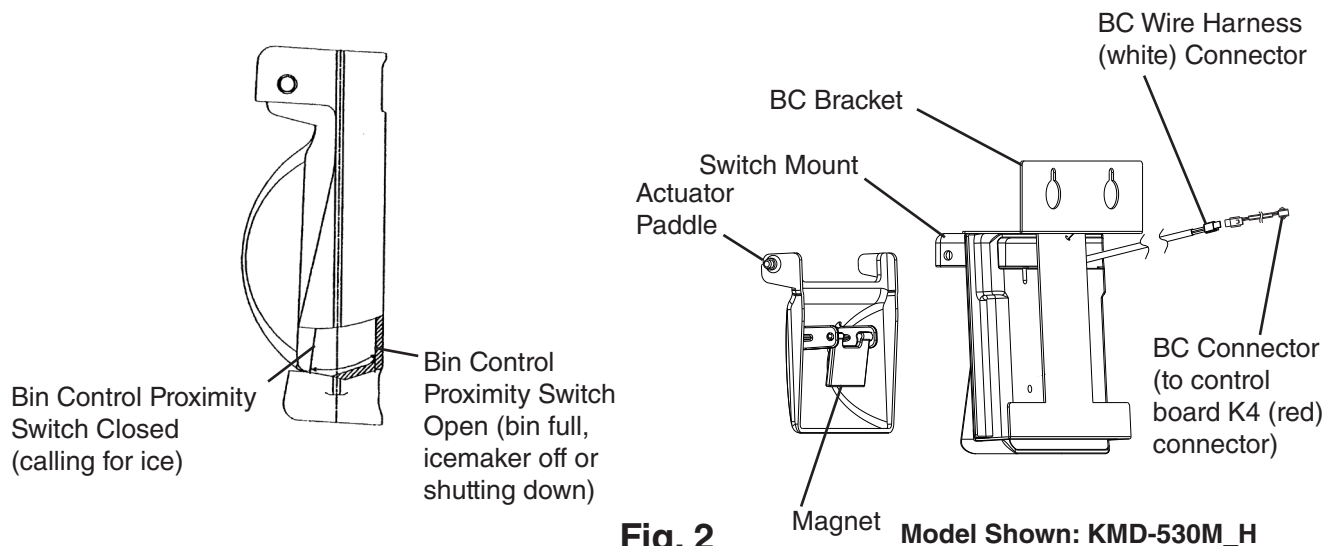

**Fig. 2**

**Model Shown: KMD-530M\_H**

## 6. Float Switch Check and Cleaning

FS is used to determine that there is sufficient water in the water tank after the 1-min. fill cycle and after each harvest cycle. FS is also used to determine that the appropriate volume of water has been converted into ice before switching out of the freeze cycle. No adjustment is required.

### a) Float Switch Check

To check FS, follow the steps below.

- 1) Turn off the power supply.
- 2) Remove the front panel and move the control switch to the "OFF" position.
- 3) Remove the front insulation panel, then remove splash guard, cube guide B, and cube guide A. Next, remove the overflow cap, overflow pipe, and water shield. See Fig. 3.
- 4) Remove the drain plug and drain the water tank. Replace the drain plug in its correct position. Be careful not to cross thread it.
- 5) Replace the water shield, overflow pipe, overflow cap, cube guide A, cube guide B, splash guard, and front insulation panel in their correct positions.  
**NOTICE! Be careful not to cross thread the overflow pipe.**
- 6) Remove the control box cover.
- 7) Disconnect the black float switch connector from the K5 connector on the control board.
- 8) Check for continuity across the float switch leads. With the water tank empty, the float switch should be open. If open, continue to step 9. If closed, follow the steps in "II.F.2. Float Switch Cleaning." After cleaning the float switch, check it again. Replace if necessary.
- 9) Reconnect the black float switch connector, then replace the control box cover.
- 10) Move the control switch to the "ICE" position. Replace the front panel in its correct position, then turn the power supply on. After 1 minute, the 1 minute fill cycle should end and the initial harvest cycle should begin. If the initial harvest cycle begins, the float switch is good and the check is complete. If the initial harvest cycle does not begin, continue to step 11.
- 11) Turn off the power supply.
- 12) Remove the front panel.
- 13) Move the control switch to the "OFF" position.
- 14) Remove the control box cover.

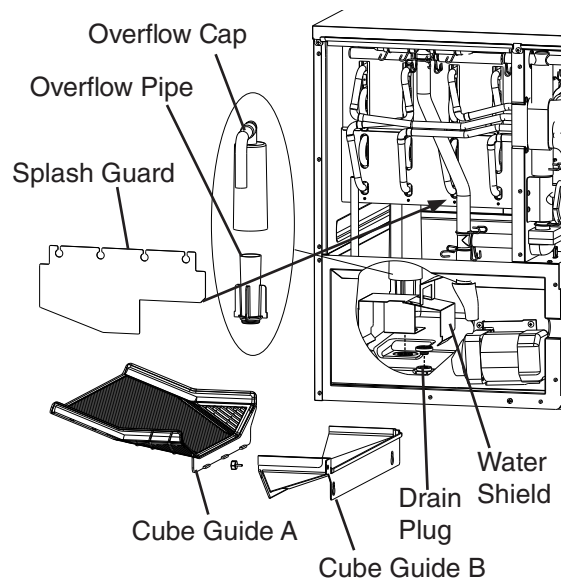

**Fig. 3**

- 15) Disconnect the black float switch connector from the K5 connector on the control board.
- 16) Check for continuity across the float switch leads. With the water tank full, the float switch should be closed. If the float switch is closed and the icemaker will not switch from the 1 minute fill cycle to the initial harvest cycle, replace the control board.

If FS is open, confirm that the water tank is full. If the water tank is not full, check the water supply, water filters, and inlet water valve. If the water tank is full, follow the steps in "II.F.2. Float Switch Cleaning." After cleaning FS, check it again. Replace if needed.

Legend: **CB**—control board; **FS**—float switch

### b) Float Switch Cleaning

Depending on local water conditions, scale may build up on FS. Scale on the switch can cause the float to stick. In this case, FS should be cleaned.

- 1) Turn off the power supply.
- 2) Remove the front panel and move the control switch to the "OFF" position.
- 3) Remove the front insulation panel, then remove splash guard, cube guide B, and cube guide A. Next, remove the overflow cap, overflow pipe, and water shield. See Fig. 3.
- 4) Remove the drain plug and drain the water tank. Replace the drain plug in its correct position. Be careful not to cross thread it.
- 5) Replace the water shield, overflow pipe, overflow cap, cube guide A, cube guide B, splash guard, and front insulation in their correct positions. **NOTICE! Be careful not to cross thread the overflow pipe.**
- 6) Disconnect the vent tube and flush tube from the top of the float switch, then remove the float switch and rubber boot.
- 7) Remove the retainer rod from the bottom of the float switch assembly, then remove the float. Be careful not to bend the retainer rod excessively when removing it. See Fig. 4.
- 8) Wipe down the float switch assembly's housing, shaft, float, and retainer rod and clean the inside of the rubber boot and hose with a mixture of 1 part of Hoshizaki "Scale Away" 25 parts of warm water. Rinse the parts thoroughly with clean water.
- 9) Reassemble the float switch assembly and replace it and the rubber boot in their correct positions. Reconnect the vent tube and the flush tube.
- 10) Move the control switch to the "ICE" position.
- 11) Replace the front panel in its correct position.
- 12) Turn on the power supply to start the automatic icemaking process.

Legend: **CB**—control board; **FS**—float switch; **PM**—pump motor

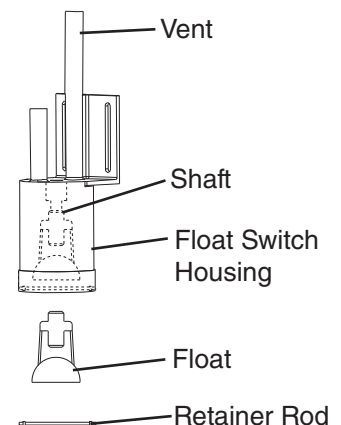

**Fig. 4**

## 7. Thermistor Check

To check thermistor resistance, follow the steps below.

- 1) Turn off the power supply.
- 2) Remove the front panel. Move the control switch to the "OFF" position.
- 3) Remove the control box cover.
- 4) Remove the thermistor from the refrigerant tubing.
- 5) Immerse the thermistor sensor portion in a glass containing ice and water for 2 or 3 min.
- 6) Disconnect the thermistor connector from CB K3 connector and check the resistance between thermistor leads. Normal range is 4.7 to 6.2 k $\Omega$ . If outside the normal range, replace the thermistor. See "IV.B. Component Service Information." If within the normal range, continue to the next step.
- 7) Replace the thermistor in its correct position. See "IV.B. Component Service Information."
- 8) Reconnect the thermistor connector to CB K3 connector.
- 9) Replace the control box cover in its correct position.
- 10) Move the control switch to the "ICE" position.
- 11) Replace the front panel in its correct position.
- 12) Turn on the power supply.
- 13) Once the harvest cycle starts (Comp energizes), begin timing the harvest cycle.
- 14) The harvest timer and harvest cycle should terminate within 2 to 5 min. If the harvest cycle does not terminate within 2 to 5 min., replace CB.

Legend: **CB**—control board; **Comp**—compressor

## 8. Control Switch

The control switch has three positions: "OFF" for power off, "ICE" for icemaking, and "WASH" to energize the pump motor when cleaning and sanitizing. **WARNING! Control switch in "OFF" position does not de-energize all loads. Risk of electric shock. Use extreme caution and exercise safe electrical practices.**

## 9. Mode Switch

The mode switch has two positions: "ICE" for icemaking cycle, "CLEAN" for initiating the cleaning and sanitizing program. Note: K1 terminal 9 (Y) is power supply through the mode switch to K1 terminal 1 (V). This prevents Comp operation during cleaning cycle. K1 terminal 1 (V) then supplies power through CB relays to K1 terminals 2 (P), 3 (BK), 4 (R), and 5 (W/BU).

Legend: **CB**—control board; **Comp**—compressor

## 10. Diagnostic Tables

### a) No Ice Production

No Ice Production - Possible Cause	
1. Power Supply	a) Off, blown fuse, or tripped breaker.
	b) Not within specifications.
2. Main Transformer	a) Voltage tap switch not set to proper voltage.
	b) Coil winding open or shorted, defective.
3. Fuse (control box)	a) Blown.
4. Control Switch	a) In "OFF" or "WASH" position.
	b) Bad contacts.
5. High-Pressure Switch	a) Dirty condenser.
	b) Fan motor not operating.
	c) Refrigerant overcharged.
	d) Bad contacts.
	e) Refrigerant lines or components plugged.
6. Control Transformer (115VAC/10.5VAC)	a) Coil winding open or shorted.
7. Control Board See "III.B.4. Control Board Check"	a) In alarm.
	b) Yellow "BC OPEN" LED on: Bin full.
	c) Defective.
8. Bin Control See "III.B.5. Bin Control Check "	a) Tripped with bin filled with ice.
	b) Actuator does not move freely.
	c) Defective.
9. Mode Switch	a) In "CLEAN" position.
	b) Defective.
10. Water Supply	a) Water supply off or improper water pressure.
	b) External water filters clogged.
11. Inlet Water Valve	a) Screen or orifice clogged.
	b) Coil winding open.
	c) Water valve open in freeze cycle.
12. Float Switch See "III.B.6. Float Switch Check and Cleaning"	a) Float does not move freely.
	b) Defective.
13. Compressor	a) Compressor relay contacts bad or coil winding open.
	b) Start capacitor or run capacitor defective.
	c) Internal protector open.
	d) Start relay contacts bad or coil winding open (single phase).
	e) Compressor defective.
14. Hot Gas Valve	a) Closed in harvest cycle.
	b) Open in freeze cycle.
15. Thermistor See "III.B.7. Thermistor Check"	a) Loose, disconnected, or defective.

<b>No Ice Production - Possible Cause</b>	
16. Pump Motor	a) Motor winding open.
	b) Bearing worn out or locked rotor.
	c) Defective capacitor.
17. Thermostatic Expansion Valve	a) Bulb loose.
	b) Operating erratically.
18. Liquid Line Valve	a) Closed in freeze cycle.
	b) Open in harvest cycle.
19. Fan Motor	a) Motor winding open.
	b) Bearing worn out or locked rotor.
	c) Defective capacitor.
20. Water System	a) Water leaks causing short freeze time.

### **b) Freeze-Up**

Defrost and clean the icemaker prior to diagnosing freeze-up. Fill out a freeze-up checklist. See "II.J. Freeze Up Check List," the Hoshizaki America Technician's Pocket Guide, or contact your local distributor for a copy of the freeze-up checklist.

<b>Freeze-Up - Possible Cause</b>	
<b>Harvest Cycle</b>	
1. Evaporator	a) Scaled up.
	b) Damaged.
2. Cube Guides	a) Out of position.
	b) Damaged.
3. Spray Tubes and/or Spray Guides	a) Dirty.
	b) Out of position.
4. Water Supply	a) Low water pressure.
	b) External water filters clogged.
	c) Insufficient water line size. Minimum 1/4" Nominal ID (6 mm Nominal OD in the EU) copper water tubing or equivalent.
5. Inlet Water Valve	a) Screen or orifice clogged.
	b) Defective.
6. Float Switch See "III.B.6. Float Switch Check and Cleaning"	a) Dirty, sticking.
	b) Defective.
7. Refrigerant Charge	a) Low.
8. Control Board See "III.B.14. Settings and Adjustments" and "III.B.4. Control Board Check"	a) Harvest timer (S4 dip switch 1 & 2) set too short.
	b) Harvest pump timer (S4 dip switch 7) not in factory default position.
	c) Defective.
9. Bin Control See "III.B.5. Bin Control Check"	a) Actuator does not move freely, sticking.
	b) Defective.
10. Thermistor See "III.B.7. Thermistor Check"	a) Loose, disconnected, or defective.

<b>Freeze-Up - Possible Cause</b>	
11. Thermostatic Expansion Valve	a) Defective.
12. Hot Gas Valve	a) Closed or restricted.
13. Liquid Line Valve	a) Open.
<b>Freeze Cycle</b>	
1. Evaporator	a) Scaled up.
	b) Damaged.
2. Spray Tubes and/or Spray Guides and Splash Guard	a) Dirty.
	b) Out of position.
3. Refrigerant Charge	a) Low.
4. Control Board See "III.B.4. Control Board Check"	a) Freeze timer (S4 dip switch 9 & 10) set incorrectly.
	b) Defective.
5. Inlet Water Valve	a) Leaking by.
6. Float Switch See "III.B.6. Float Switch Check and Cleaning"	a) Float does not move freely.
	b) Defective.
7. Pump Motor	a) RPM too slow.
	b) Impeller damaged.
8. Thermostatic Expansion Valve	a) Bulb loose or defective.
9. Liquid Line Valve	a) Restricted.

### **c) Low Ice Production**

<b>Low Ice Production - Possible Cause</b>	
<b>Long Harvest Cycle</b>	
1. Evaporator	a) Scaled up.
2. Spray Tubes and/or Spray Guides	a) Dirty.
	b) Out of position.
3. Refrigerant Charge	a) Low.
4. Water Supply	a) Low water pressure.
	b) External water filters clogged.
	c) Insufficient water line size. Minimum 1/4" Nominal ID (6 mm Nominal OD in the EU) water tubing or equivalent.
	d) Too cold.
5. Control Board See "III.B.4. Control Board Check"	a) Thermistor connection loose (K3).
	b) Defective.
6. Thermistor See "III.B.7. Thermistor Check"	a) Loose, disconnected, or defective.
7. Hot Gas Valve	a) Erratic or closed.
8. Inlet Water Valve	a) Screen or orifice clogged.
9. Compressor	a) Inefficient or off.
10. Liquid Line Valve	a) Erratic or open.
11. Thermostatic Expansion Valve	a) Defective.

<b>Low Ice Production - Possible Cause</b>	
<b>Long Freeze Cycle</b>	
1. Evaporator	a) Scaled up, dirty.
2. Float Switch See "III.B.6. Float Switch Check and Cleaning"	a) Scaled up, dirty.
	b) Float sticking.
	c) Defective switch.
3. Inlet Water Valve	a) Leaking by.
4. Hot Gas Valve	a) Erratic or open.
5. Condenser	a) Clogged.
6. Control Board See "III.B.4. Control Board Check"	a) Float switch connection loose (K5).
	b) Defective.
7. Refrigerant Charge	a) Low.
8. Thermostatic Expansion Valve	a) Bulb loose.
	b) Defective.
9. Compressor	a) Inefficient or off.
10. Pump Motor	a) RPM too slow.
11. Liquid Line Valve	a) Erratic or restricted.

# 11. Freeze-Up Check List

**Freeze-Up Check List**  
**Please Complete When Diagnosing a Freeze-Up, Refrigerant Leak, or Low Charge**  
 Technical Support Fax #: 770-487-3360  
 Make Copies And Use As Needed

**Model #** \_\_\_\_\_ **Serial #** \_\_\_\_\_ **Install Date** \_\_\_\_\_ **Freeze-Up Date** \_\_\_\_\_

List model and manufacture of bin or dispenser \_\_\_\_\_.

Date appliance was last cleaned: \_\_\_\_\_.

**Freeze-Up Defrost**

YES NO

- 1) After defrosting, was the appliance leak checked?
- 2) Were any leaks found?  
If so where? \_\_\_\_\_.
- 3) Was any refrigerant added to the unit?  
If so, how much? \_\_\_\_\_.

**Set Up**

- 4) Is the appliance stand alone?
- 5) Is water line independent?
- 6) Is water line correct size? If not \_\_\_\_\_,"  
3/8" Nominal ID Copper Water Tubing or Equivalent.
- 7) What is water pressure? \_\_\_\_\_.  
Water Temperature \_\_\_\_\_.
- 8) Does appliance have any water filtration?  
If yes please list the following:  
Filter brand \_\_\_\_\_.  
Model \_\_\_\_\_.  
Filter pressure gauge reading during the fill cycle \_\_\_\_\_.  
Date filter was last replaced? \_\_\_\_\_.  
GPM or LPM flow rate of filter system? \_\_\_\_\_.
- 9) Ambient temperature at appliance? \_\_\_\_\_.  
At remote condenser (if applicable)? \_\_\_\_\_.

**Appliance Status**

- 10) Is the appliance and/or float switch dirty?
- 11) List the S4 (1-10) and S5 (1-5) DIP switch settings.  
S4: 1 \_\_\_ 2 \_\_\_ 3 \_\_\_ 4 \_\_\_ 5 \_\_\_ 6 \_\_\_ 7 \_\_\_ 8 \_\_\_ 9 \_\_\_ 10 \_\_\_  
S5: 1 \_\_\_ 2 \_\_\_ 3 \_\_\_ 4 \_\_\_ 5 \_\_\_
- 12) Is DIP switch number 7 ON (harvest pump time (harvest assist)) all models?
- 13) Is the cube guide positioned correctly?
- 14) Are the evaporator separators positioned properly?
- 15) Is the thermistor properly mounted, tight, and insulated?
- 16) Is the TXV bulb properly mounted, tight, and insulated?
- 17) Are splash guards in place (if applicable)?

**Appliance Sequence of Operation**

**Fill**

YES NO

- 18) Does the water tank fill and overflow?  
60-90 sec. Note: Larger models may take up to 120 seconds to overflow when empty.
- 19) If NO in step 17, is water flow 5GPM for larger?

**Harvest**

- 20) Is the hot gas valve opening?
- 21) Is harvest pump time (harvest assist) on (S4 dip switch 7)?
- 22) Is hot gas valve opening in harvest?
- 23) Does water valve close completely when deenergized?
- 24) What was length of harvest? \_\_\_\_\_.

**Freeze**

- 25) Is pump motor energized in freeze cycle except during 10-sec. anti-slush. If activated (S5 dip switch 5 on)?
- 26) Water-cooled condenser outlet temperature 5-min. into freeze? \_\_\_\_\_°F.
- 27) What was length of freeze time? \_\_\_\_\_.
- 28) Is the cube size consistent from inlet to outlet of evaporator?
- 29) Is ice still dropping when next freeze cycle starts?
- 30) What is the ice drop weight? \_\_\_\_\_.
- 31) What is head pressure?  
Freeze \_\_\_\_\_ Harvest \_\_\_\_\_.  
(Freeze pressure should be taken 5 minutes into the freeze cycle).
- 32) What is suction pressure?  
Freeze \_\_\_\_\_ Harvest \_\_\_\_\_.  
(Freeze pressure should be taken 5 minutes into the freeze cycle).
- 33) When activating bin control, did appliance shutdown within 15 seconds in the first 5 minutes of freeze cycle?

**Freeze-Up Detection**

- 34) Has Freeze-Up Detection been activated? ("POWER" LED blinking)  
See "III.B.4. Freeze-Up Detection Cycle (FUD)."
- 35) If activated, has there been 6 normal freeze cycles without FUD activation?
- 36) Is length of freeze time back to normal?

Note: Make copies of this form and use it when diagnosing a freeze up condition. Submit a completed copy of the checklist along with the freeze-up labor claim form.

## 12. Control Board, Control Board Layout, Settings, and Adjustments

- A Hoshizaki exclusive control board is employed in KM series appliances.
- All models are pretested and factory adjusted.
- For a control board check procedure, see "III.B.5. Control Board Check."

### ***NOTICE***

- Fragile, handle very carefully.
- The control board contains integrated circuits, which are susceptible to failure due to static discharge. It is especially important to touch the metal part of the icemaker when handling or replacing the control board.
- Do not touch the electronic devices on the control board or the back of the control board.
- Do not change wiring and connections. Do not misconnect K3 WHITE, K4 RED, and K5 BLACK, because the same connector is used for the thermistor, mechanical bin control and float switch.
- Do not short out power supply to test for voltage.
- Always replace the whole control board assembly if it goes bad.

# 13. Control Board Layout

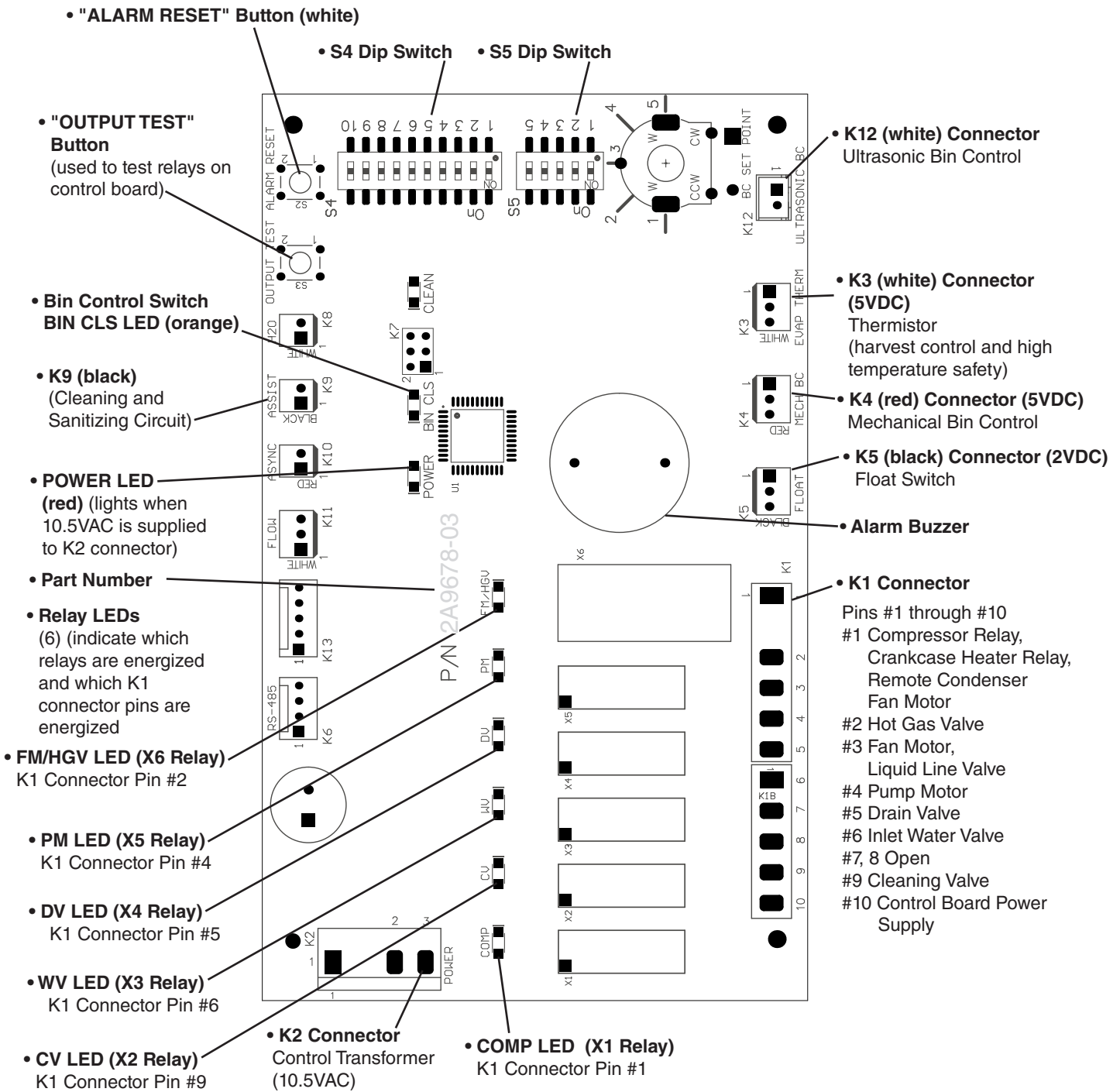

Control Board	
Part Number	2A9678-03

#### 14. LED Lights and Audible Alarm Safeties

Beep occurs and red CB "POWER" LED turns on when control switch is moved to "ICE" position.

#### Sequence

Green LEDs turn on and sequence from initial startup as listed in the table below. Order of green LEDs from the outer edge of control board is Comp, CV, WV, DV, PM, FM/HGV.

Sequence Step	LED	Energized Components	Time LEDs are On	
			Min.	Max.
1-Minute Fill Cycle	WV	WV		
Harvest Cycle	Comp, WV, FM/HGV	Comp, HGV, WV	1 minute	20 minutes
Harvest Pump Time (harvest assist)	Comp, PM, FM/HGV	Comp, HGV, PM	0 seconds	50 seconds
Freeze Cycle	Comp, PM	Comp, FM, PM, LLV	5 minutes	freeze timer setting
Anti-Slush Control	Comp	Comp, FM, LLV	PM off 10 sec. when thermistor at 36°F (2°C)	
Pump-Out Cycle	Comp, PM, FM/HGV, DV, WV	Comp, HGV, PM, WV, DV	10 seconds	20 seconds
pump-out timer setting FM is OFF when FM/HGV is ON				

#### Alarms

Type	Alarm	Notes
1 Beep	High Evaporator Temp. (temperature > 127°F) (53°C)	Check for harvest problem (stuck HGV or relay), hot water entering unit or shorted thermistor.
2 Beep	Harvest Backup Timer (harvest > 20 min. for two cycles in a row)	Check thermistor (open), HGV not opening, TXV or LLV leaking by, low charge, inefficient Comp.
3 Beep	Freeze Timer (freeze > freeze timer setting for two cycles in a row)	Check FS stuck closed (up), WV leaking by, HGV leaking by, PM not pumping, TXV defective, LLV not opening, low charge, or inefficient Comp.
To reset above safeties, press "ALARM RESET" button with power supply on.		
6	Low Voltage (92Vac±5% or less)	Red LED turns off if voltage protection operates. Control voltage safeties automatically reset when voltage is corrected.
7	High Voltage (147Vac±5% or more)	
LED Blink Only	Freeze Up Detection Cycle	Freeze up detection cycle initiated. "POWER" LED blinks until 6 FS activated freeze cycles completed or control board manually reset.

Legend: **Comp**—compressor; **CV**—cleaning valve; **DV**—drain valve; **FM**—fan motor; **FS**—float switch; **HGV**—hot gas valve; **LLV**—liquid line valve; **PM**—pump motor; **TXV**—thermostatic expansion valve; **WV**—inlet water valve

## 15. Settings and Adjustments

### **NOTICE**

Dip switches are factory set. Failure to maintain factory settings may adversely affect performance and warranty coverage. For more information, contact your Hoshizaki Service Center.

#### a) Default Dip Switch Settings

The dip switches are factory-adjusted to the following positions for the control board: 2A7664-01, 2A7664-02, and 2A7664-04 control boards:

S4 Dip Switch										
Model	1	2	3	4	5	6	7	8	9	10
KM-830MAK2	OFF	OFF	OFF	OFF	OFF	OFF	ON	OFF	OFF	OFF

S5 Dip Switch (Do Not Adjust)					
Model	1	2	3	4	5
All Models	OFF	OFF	ON	OFF	ON

### **S4 Dip Switch**

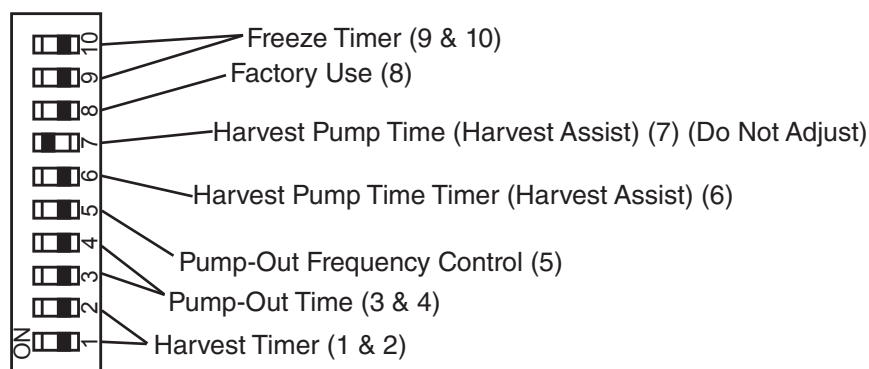

### **S5 Dip Switch (Do Not Adjust)**

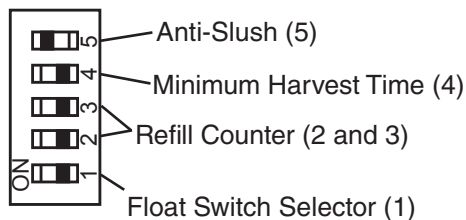

**b) Harvest Time (S4 dip switch 1 & 2)**

The harvest timer starts counting when the thermistor reaches 48°F (9°C) at the evaporator outlet and the control board reads 3.9 kΩ from the thermistor. The harvest timer is factory set, and generally no adjustment is required. However, a setting longer than the factory setting may be advised in cases where the drain provided at harvest needs to be prolonged for extra cleaning. Note that the pump-out timer (S4 dip switch 3 & 4) acts in place of the harvest timer during cycles with a pump out. For details, see "III.C.3. Pump-Out Timer (S4 dip switch 3 & 4)."

Note: On models with a pump-out every cycle, the harvest timer is only relevant during the initial harvest cycle since a pump out occurs every cycle thereafter.

S4 Dip Switch Setting		Time (sec.)	
No. 1	No. 2	S5-4 OFF	S5-4 ON
OFF	OFF	60	30
ON	OFF	90	45
OFF	ON	120	60
ON	ON	180	75

**c) Pump-Out Time/Harvest Time During Pump-Out (S4 dip switch 3 & 4)**

<b>NOTICE</b>
Do not adjust 3 off and 4 on. Pump motor does not run in pump-out rotation in this setting.

When a pump-out is called for, the pump motor stops for 2 sec., then energizes in the reverse direction, taking water from the bottom of the water tank and forcing pressure against the check valve seat allowing water to go through the check valve and down the drain. At the same time, water flows through the small tube to power flush the float switch. The pump motor drains the water tank for the time determined by the pump-out timer. The pump-out timer also acts in place of the harvest timer during cycles with a pump-out. The pump-out timer is factory set, and generally no adjustment is required. However, where water quality is bad and the icemaker needs a longer pump-out time, the pump-out timer can be adjusted. The pump-out time can be set to pump-out for 10 or 20 sec. During pump-out cycles minimum harvest time is based on times given in the table below.

S4 Dip Switch Setting		Time (sec.)			Inlet Water Valve	
No. 3	No. 4	T1	T2		S5-4 OFF	S5-4 ON
			S5-4 OFF	S5-4 ON		
OFF	OFF	10	150	100	Closed	Closed
ON	OFF	10	180	130	Closed	Closed
OFF	ON	10	120	70	Open	Closed
ON	ON	20	180	180	Closed	Closed

T1: Time to drain the water tank

T2: Harvest timer at pump out

**d) Pump-Out Frequency Control (S4 dip switch 5)**

The pump-out frequency control is factory set to drain the water tank every 10 cycles. Generally no adjustment is required. However, where water quality is bad and the icemaker needs a pump-out more often, the pump-out frequency can be adjusted. The pump-out frequency control can be set to have a pump-out occur every cycle, or every 10 cycles.

The first pump-out is dependent on S4 dip switch 5. See the table below.

<b>S4 Dip Switch Setting</b>	<b>Pump-Out Frequency</b>	<b>1st Pump-Out</b>
<b>No. 5</b>		
OFF	Every 10 cycles	After 11th freeze cycle
ON	Every cycle	After 2nd freeze cycle

**e) Harvest Pump Time (Harvest Assist) (S4 dip switch 6)**

<b><i>NOTICE</i></b>
Factory set for proper operation. Do not adjust. Adjustment outside of the factory default setting may result in damage to the appliance.

Harvest pump time (harvest assist) is only active when S4 dip switch 7 is in the "ON" position. In the factory default position, the harvest pump time (harvest assist) starts with 50 sec. left to go in harvest cycle (S4 dip switch 6) and after the thermistor reaches 48°F (9°C) at the evaporator outlet and the control board reads 3.9 kΩ from the thermistor. The harvest pump time (harvest assist) is factory set, and no adjustment is required.

<b>S4 Dip Switch Setting</b>	<b>Harvest Pump Time (Harvest Assist)</b>	
	<b>S5-4 OFF</b>	<b>S5-4 ON</b>
No. 6		
OFF	50 sec.	25 sec.
ON	25 sec.	15 sec.

**f) Harvest Pump Time (Harvest Assist) (S4 dip switch 7)**

**NOTICE**

Factory set for proper operation. Do not adjust. Adjustment outside of the factory default setting may result in damage to the appliance.

**a) Harvest Pump Time (Harvest Assist)**

Depending on S4 dip switch 7 setting, the pump motor either stays off or is energized during the last seconds of the harvest cycle. When the pump motor is energized (S4 dip switch 7 on), water circulates over the evaporator. The harvest water valve is open during harvest for a maximum of 6 minutes or the length of harvest minus the harvest pump time value (S4 dip switch 6), whichever is shorter.

When S4 dip switch 7 is in the on position and harvest begins, X11 and X10 relays energize. A latching circuit is created through the X11 and X10 relays. For further details, see "VIII.B. Wiring Diagram." In the factory default position, 50 sec. before harvest termination, LED 4 turns off, inlet water valve and X11 relay de-energize. X10 relay remains energized through the latching circuit. Next, LED 3 turns on and control board K1 connector pin #5 (DBU wire) energizes, energizing the pump motor for the last seconds of harvest. Harvest pump time adjusted by S4 dip switch 1 & 2 and S5 dip switch 4 settings. Contact Technical Support before adjusted these settings.

**b) Freeze-Time Correction**

When S4 dip switch 7 is in the on position, freeze-time correction enabled. See "II.C. Freeze-Time Correction Cycle (90 min.)."

<b>S4 Dip Switch Setting</b>	<b>Harvest Pump Time (Harvest Assist)</b>
<b>No. 7</b>	
OFF	Disabled
ON	Enabled

**g) Factory Use (S4 dip switch 8)**

Factory set for proper operation. Do not adjust. This must be left in the factory default position.

#### h) Freeze Timer (S4 dip switch 9 & 10)

### **NOTICE**

Adjust to proper specification, or the icemaker may not operate correctly.

The freeze timer setting determines the maximum allowed freeze time to prevent possible freeze-up issues. Upon termination of the freeze timer, the control board initiates the harvest cycle or pump-out cycle. After 2 consecutive freeze timer terminations, the control board shuts down the icemaker. In this case, see "II.1.3. Low Ice Production" for possible solutions. The freeze timer is factory set and no adjustment is required. Before changing this setting, contact Hoshizaki Technical Support at 1-800-233-1940 for recommendations.

S4 Dip Switch Setting		Time (min.)
No. 9	No. 10	
OFF	OFF	60
OFF	ON	50
ON	OFF	70
ON	ON	75

#### i) Float Switch Selector (S5 dip switch 1)

This dip switch setting allows use of this control board in single and dual float switch models. This model uses a single float switch style.

### **NOTICE**

Do not adjust. This must be left in the factory default position or the icemaker will not operate correctly.

S5 Dip Switch Setting	Top or Bottom Float Switch Control
No. 1	
OFF	Bottom Float Switch Enabled
ON	Top Float Switch Enabled

#### j). Refill Counter (S5 dip switch 2 and 3)

### **NOTICE**

Do not adjust. These must be left in the factory default position or the icemaker will not operate correctly.

S5 Dip Switch Setting		Refill Counter
No. 2	No. 3	
OFF	OFF	0
OFF	ON	1 refill
ON	OFF	9 refills
ON	ON	10 refills

**k) Minimum Harvest Time (S5 dip switch 4)**

<b>NOTICE</b>
Factory set for proper operation. Do not adjust. Adjustment outside the factory default setting may result in damage to the appliance.

<b>S5 Dip Switch Setting</b>	<b>Minimum Harvest Timer</b>
<b>No. 4</b>	
OFF	120 sec.
ON	70 sec.

**l) Anti-Slush (S5 dip switch 5)**

This dip switch setting provides anti-slush control during the freeze cycle. When the evaporator temperature reaches 36°F (2.2°C) the control board reads a 5.8kΩ signal from the thermistor and de-energizes the water pump for 10 sec. to melt ice slush and prevent ice slush from blocking the water supply tubing, causing irregular freeze patterns.

<b>NOTICE</b>
Factory set for proper operation. Do not adjust. Adjustment outside the factory default setting may result in damage to the appliance.

<b>S5 Dip Switch Setting</b>	<b>Anti-Slush</b>
<b>No. 5</b>	
OFF	Disabled
ON	Enabled

## C. Refrigeration Circuit Service



### R-290 Class A3 Flammable Refrigerant Used

#### **⚠ DANGER**

##### **Risk of Fire or Explosion. Flammable Refrigerant Used.**

- Be sure to follow all Important Safety Information located at the beginning of this manual and at the beginning of section "III.A. Safety Precautions When Servicing."
- Servicing shall be done by trained service personnel with certified competence in handling flammable refrigerants to minimize the risk of possible ignition due to incorrect parts or improper service.
- Confirm that capacitors are discharged: this shall be done in a safe manner to avoid possibility of sparking.
- A dry chemical or CO<sub>2</sub> fire extinguisher should be adjacent to the charging area. You must have a Class B chemical fire extinguisher available at all times.
- When breaking into the refrigerant circuit to make repairs – or for any other purpose – conventional procedures shall be used. However, for flammable refrigerants it is important that best practice be followed, since flammability is a consideration. The following procedure shall be adhered to:
  - safely remove refrigerant following local and national regulations
  - purge the circuit with inert gas
  - evacuate (optional for A2L)
  - purge with inert gas (optional for A2L)
  - open the circuit by cutting or brazing
- Confirm that no live electrical components and wiring are exposed while charging, recovering, or purging the system.
- You must have a combustible gas leak detector in the immediate work area at all times.
- Be sure the area is clear of refrigerant vapor before brazing.
- The refrigerant charge shall be recovered into the correct recovery cylinders if venting is not allowed by local and national codes. For appliances containing flammable refrigerants, the system shall be purged with oxygen-free nitrogen to render the appliance safe for flammable refrigerants. This process might need to be repeated several times. Compressed air or oxygen shall not be used for purging refrigerant systems.

## **⚠ DANGER Continué**

### **Risque De Feu Ou D'Explosion. Fluide Frigorigène Inflammable Utilisé.**

- Assurez-vous de suivre toutes les informations importantes de sécurité qui se trouvent au début du présent manuel et au début de la section «III.A. Précautions de sécurité lors de l'entretien.»
- L'entretien doit être effectué par du personnel formé et certifié pour la manipulation de réfrigérants inflammables afin de réduire au minimum le risque d'inflammation dû à des pièces incorrectes ou à un entretien inadéquat.
- S'assurer que les condensateurs sont déchargés : cette opération doit être effectuée en toute sécurité afin d'éviter tout risque d'étincelle.
- Un extincteur à poudre chimique ou à CO<sub>2</sub> devrait être installé à proximité de la zone de chargement. Un extincteur chimique de classe B doit être disponible à tout moment.
- Pour pénétrer dans le circuit du réfrigérant afin d'effectuer des réparations ou pour toute autre raison, des procédures conventionnelles doivent être utilisées. Toutefois, pour les réfrigérants inflammables, il est important de suivre les meilleures pratiques, car l'inflammabilité est un facteur à prendre en considération. La procédure suivante doit être respectée:
  - éliminer le réfrigérant en toute sécurité conformément aux réglementations locales et nationales
  - purger le circuit avec du gaz inerte
  - évacuer (en option pour A2L)
  - purger avec du gaz inerte (en option pour A2L)
  - ouvrir le circuit par coupure ou brasage
- S'assurer qu'aucun composant ou câblage électrique sous tension n'est exposé lors de la charge, de la récupération ou de la purge du système.
- Vous devez avoir un détecteur de fuite de gaz combustible dans la zone de travail immédiate en tout temps.
- Assurez-vous que la zone est dégagée de la vapeur de réfrigérant avant de braser.
- La charge réfrigérante doit être récupérée dans les bouteilles de récupération correctes si la ventilation n'est pas autorisée par les codes locaux et nationaux. Pour les appareils contenant des réfrigérants inflammables, le système doit être purgé avec de l'azote exempt d'oxygène pour assurer la sécurité de l'appareil pour les réfrigérants inflammables. Ce processus peut être répété plusieurs fois. L'air comprimé ou l'oxygène ne doivent pas être utilisés pour la purge des systèmes de réfrigérants.

### **⚠ WARNING**

- Wear appropriate personal protective equipment (PPE) when servicing the appliance.
- Notify all persons in the immediate area that you are working with a flammable refrigerant.
- Do not use silver alloy or copper alloy containing arsenic.

#### **a) Refrigerant Recovery**

Using proper refrigerant practices, place piercing valves toward the end (crimped area) of the high and low-side process tubes, then recover the refrigerant into an approved container or device.

- 1) Move the control switch to the "OFF" position, then turn off the power supply before servicing. Lockout/Tagout to prevent the power supply from being turned back on inadvertently.

#### **b) Brazing**

- 2) Prior to brazing, purge with nitrogen gas for 2 min., flowing at a pressure of 3 to 5 PSIG.  
**⚠ DANGER! For appliances containing flammable refrigerants, the system shall be purged with oxygen-free nitrogen to render the appliance safe for flammable refrigerants. This process might need to be repeated several times. Compressed air or oxygen shall not be used for purging refrigerant systems.**
- 3) Braze/repair/replace damaged component or fittings while purging with nitrogen gas, flowing at a pressure of 3 to 5 PSIG.

### **NOTICE**

- Do not leave the system open for longer than 15 min. when replacing or servicing parts. The Polyol Ester (POE) oils used in R-290 applications can absorb moisture quickly. Therefore it is important to prevent moisture from entering the system when replacing or servicing parts.
- Always install a new drier every time the sealed refrigeration system is opened. Do not replace the drier until after all other repair or replacement has been made. Install the new drier with the arrow on the drier in the direction of the refrigerant flow.
- When brazing, protect the drier by using a wet cloth to prevent the drier from overheating. Do not allow the drier to exceed 250°F (121°C).

- 4) Use soap bubbles to check for leaks. Raise the pressure using nitrogen gas (190 PSIG). Do not use any refrigerant as a mixture with pressurized air for leak testing.
- 5) Once leak checking is complete, release the nitrogen gas from the system.

### c) Evacuation

- 6) Attach a vacuum pump to the system. Be sure the high-side charging hose is connected to the field-installed high-side access valve.

<b><i>IMPORTANT</i></b>
-------------------------

The vacuum level and vacuum pump may be the same as those for current refrigerants. However, the rubber hose and gauge manifold to be used for evacuation and refrigerant charge should be exclusively for POE oils.
--

- 7) Turn on the vacuum pump, then open the high-side valve on the gauge manifold. Never allow the oil in the vacuum pump to flow backwards.
- 8) Allow the vacuum pump to pull down to a 29.9" Hg vacuum. Evacuating period depends on pump capacity.
- 9) Close the high-side valve on the gauge manifold.
- 10) Disconnect the gauge manifold hose from the vacuum pump and attach it to a refrigerant service cylinder. Remember to loosen the connection and purge the air from the hose. See the nameplate for the required refrigerant charge. Hoshizaki recommends only virgin refrigerant or reclaimed refrigerant which meets the requirements of AHRI Standard 700 (latest edition) be used.

## d) Recharge

### DANGER

• In addition to conventional charging procedures, the following requirements shall be followed:

- Ensure that contamination of different refrigerants does not occur when using charging equipment. Hoses or lines shall be as short as possible to minimize the amount of refrigerant contained in them.
- Cylinders shall be kept in an appropriate position according to the instructions.
- Ensure that the refrigerating system is earthed (grounded) prior to charging the system with refrigerant.
- Label the system when charging is complete (if not already).
- Extreme care shall be taken not to overfill the refrigerating system.

• The system shall be leak-tested on completion of charging but prior to commissioning. A follow up leak test shall be carried out prior to leaving the site.

• En plus des procédures de charge conventionnelles, les exigences suivantes doivent être respectées :

- S'assurer qu'aucune contamination de différents réfrigérants ne se produit lors de l'utilisation de l'équipement de charge. Les tuyaux ou conduites doivent être aussi courts que possible afin de minimiser la quantité de réfrigérant qu'ils contiennent.
- Les bouteilles doivent être maintenues dans une position appropriée conformément aux instructions.
- S'assurer que le système de réfrigération soit mis à la terre avant de charger le système avec du réfrigérant.
- Étiqueter le système lorsque la charge est terminée (si cela n'a pas déjà été fait).
- Il faut veiller à ne pas trop remplir le système de réfrigération.

• Avant de recharger le système, celui-ci doit être testé sous pression avec le gaz de purge approprié. Le système doit être soumis à un essai de fuite à la fin de la charge, mais avant la mise en service. Un test de contrôle de fuite doit être effectué avant de quitter le site.

- 11) R-290 can be charged in either the liquid or vapor state. Liquid charge is preferred. If refrigerant charging is done in the liquid state, place the service cylinder on the scales; **if the service cylinder is not equipped with a dip tube, invert the service cylinder, then place it on the scales.** Open the high-side valve on the gauge manifold.
- 12) Allow the system to charge with liquid until the proper charge weight is met.
- 13) Close the high-side valve on the gauge manifold. If charging is complete, skip to step 15.

- 14) If necessary, add any remaining charge to the system through the low-side.  
**NOTICE! To prevent compressor damage, use a throttling valve or liquid dispensing device to add the remaining liquid charge through the low-side refrigerant access valve with the compressor running.** Close the refrigerant cylinder valve and let the low-side refrigerant equalize to the system, then close the low-side manifold gauge.
- 15) Pinch off (crimp down) the process tubes just below the piercing valves.
- 16) Remove the piercing valves. Cut the process tubes to remove the piercing valve holes.
- 17) Confirm there are no leaks from the pinched off process tubes, then braze the process tubes closed. **⚠ DANGER! Be sure there is no refrigerant leak before brazing.**
- 18) Use a combustible gas leak detector or soap bubbles to check for leaks again.
- 19) Place red sleeves over the process tubes.
- 20) Plug the appliance back into the electrical outlet.

## D. Component Service Information



### R-290 Class A3 Flammable Refrigerant Used

#### **⚠ DANGER**

##### **Risk of Fire or Explosion. Flammable Refrigerant Used.**

- Be sure to follow all Important Safety Information located at the beginning of this manual and at the beginning of section "III.A. Safety Precautions When Servicing."
- Component parts shall be replaced with like components. So as to minimize the risk of possible ignition due to incorrect parts.
- This appliance should be diagnosed and repaired only by qualified service personnel to reduce the risk of death, electric shock, serious injury, or fire.
- Repair and maintenance to electrical components shall include initial safety checks and component inspection procedures. If a fault exists that could compromise safety, then no electrical supply shall be connected to the circuit until it is satisfactorily dealt with. If the fault cannot be corrected immediately but it is necessary to continue operation, an adequate temporary solution shall be used. This shall be reported to the owner of the equipment, so all parties are advised.
- Confirm that capacitors are discharged: this shall be done in a safe manner to avoid possibility of sparking.
- Confirm that no live electrical components and wiring are exposed while charging, recovering, or purging the system.
- Confirm that there is continuity of earth bonding (grounding).

## ⚠ DANGER Continué

### Risque D'Incendie ou D'Explosion. Fluide Frigorigène Inflammable Utilisé.

- Assurez-vous de suivre toutes les informations importantes de sécurité qui se trouvent au début du présent manuel et au début de la section «III.A. Précautions de sécurité lors de l'entretien.»
- Les pièces doivent être remplacées par des pièces similaires, de manière à réduire au minimum le risque d'inflammation dû à des pièces incorrectes.
- Cet appareil ne doit être diagnostiqué et réparé que par un personnel qualifié afin de réduire les risques de mort, d'électrocution, de blessures graves ou d'incendie.
- La réparation et l'entretien des composants électriques incluent les contrôles de sécurité initiaux et les procédures d'inspection des composants. En cas de défaut susceptible de compromettre la sécurité, aucune alimentation électrique ne doit être connectée au circuit tant que le problème n'a pas été résolu de manière satisfaisante. Si le défaut ne peut être corrigé immédiatement mais qu'il est nécessaire de poursuivre l'exploitation, une solution temporaire adéquate doit être utilisée. Cela doit être signalé au propriétaire de l'équipement, afin que toutes les parties soient informées.
- S'assurer que les condensateurs sont déchargés : cette opération doit être effectuée en toute sécurité afin d'éviter tout risque d'étincelle.
- S'assurer qu'aucun composant ou câblage électrique sous tension n'est exposé lors de la charge, de la récupération ou de la purge du système.
- S'assurer de la continuité de la mise à la terre.

### **NOTICE**

When replacing a component listed below, see the notes to help ensure proper operation.

Component	Notes
Compressor	1 phase: Install a new start capacitor, run capacitor, and start relay.
Thermostatic Expansion Valves	<ul style="list-style-type: none"> <li>• Attach the thermostatic expansion valve bulb to the suction line in the same location as the previous bulb.</li> <li>• The bulb should be between the 10 and 2 o'clock positions on the tube.</li> <li>• Secure the bulb with the clamp and holder, then insulate it.</li> </ul>
Hot Gas Valves Liquid Line Valves	<ul style="list-style-type: none"> <li>• Replace the strainer if applicable.</li> <li>• Use copper tube of the same diameter and length when replacing valve lines.</li> </ul>
Fan Motors	Install a new capacitor.
Pump Motor	Install a new capacitor.
Thermistor	<ul style="list-style-type: none"> <li>• Attach the new thermistor to the suction line in the same location as the previous thermistor.</li> <li>• The thermistor should be at the 12 o'clock position on the tube.</li> <li>• Smoothly fill the recessed area of the thermistor holder with high thermal conductive type sealant. Hoshizaki America part number 4A0683-01 (Silicone Heat Sink Compound 10-8108 manufactured by GC Electronics), KE-4560 RTV (manufactured by ShinEtsu Silicones), or equivalent are recommended.</li> <li>• Secure the thermistor with the holder, then insulate it.</li> <li>• Be very careful to prevent damage to the leads.</li> </ul>

## IV. Maintenance

The maintenance schedule below is a guideline. More frequent maintenance may be required depending on water quality, the appliance's environment, and local sanitation regulations

<b>⚠ WARNING</b>	
<ul style="list-style-type: none"> <li>• Only qualified service technicians should service the appliance.</li> <li>• To reduce the risk of electric shock, do not touch the control switch or service switch with damp hands</li> <li>• Before servicing: Move the control switch to the "OFF" position and turn off the power supply. Place the disconnect in the "OFF" position. Lockout/Tagout to prevent the power supply from being turned back on inadvertently.</li> <li>• <b>CHOKING HAZARD:</b> Ensure all components, fasteners, and thumbscrews are securely in place after any maintenance is done to the icemaker. Make sure that none have fallen into the dispenser unit/ice storage bin.</li> </ul>	

<b>Maintenance Schedule</b>		
<b>Frequency</b>	<b>Area</b>	<b>Task</b>
Daily	Scoop	Clean the ice scoop using a neutral cleaner. Rinse thoroughly after cleaning.
Bi-Weekly	Air Filters	Inspect. Wash with warm water and neutral cleaner if dirty.
Monthly	External Water Filters	Check for proper pressure and change if necessary.
	Icemaker Exterior	Wipe down with a clean, soft cloth. Use a damp cloth containing a neutral cleaner to wipe off oil or dirt build up. Clean any chlorine staining (rust colored spots) using a non-abrasive cleanser.
	Underside of Icemaker and Top Kits; Bin Door and Snout	Wipe down with a clean cloth and warm water.
Yearly	Icemaker and Dispenser Unit/Ice Storage Bin Liner	Clean and sanitize per the cleaning and sanitizing instructions provided in the instruction manual or maintenance label on the icemaker.
	Water Supply Inlet	Close the icemaker water supply line shut-off valve and drain the water system. Clean the water supply inlet screen.
	Condenser	Inspect. Clean if necessary by using a brush or vacuum cleaner. More frequent cleaning may be required depending on location.
	Water Hoses	Inspect the water hoses and clean/replace if necessary.

---

## V. Preparing the Icemaker for Periods of Non-Use

<b>NOTICE</b>
<ul style="list-style-type: none"><li>• When storing the icemaker for an extended time or in sub-freezing temperatures, follow the instructions below to prevent damage.</li><li>• To prevent damage to the water pump seal, do not leave the control switch in the "WASH" position for extended periods when the water tank is empty.</li></ul>



When the icemaker is not used for two or three days under normal conditions, it is sufficient to move the control switch to the "OFF" position. When storing the icemaker for an extended time or in sub-freezing temperatures, follow the instructions below.

### 1. Remove the water from the icemaker water supply line:

- 1) Turn off the power supply, then remove the front panel.
- 2) Move the control switch to the "OFF" position.
- 3) Close the icemaker water supply line shut-off valve, then open the icemaker water supply line drain valve.
- 4) Allow the line to drain by gravity.
- 5) Attach a compressed air or carbon dioxide supply to the icemaker water supply line drain valve.
- 6) Move the control switch to the "ICE" position.
- 7) Replace the front panel in its correct position, then turn on the power supply.
- 8) Blow the icemaker water supply line out using the compressed air or carbon dioxide supply.
- 9) Close the icemaker water supply line drain valve.

### 2. Drain the water tank:

- 1) Turn off the power supply, then remove the front panel.
- 2) Move the control switch to the "OFF" position.
- 3) Remove the front insulation panel. Remove splash guard, cube guide B, then remove cube guide A. Remove the overflow cap, overflow pipe, and water shield. See Fig. 3.
- 4) Remove the drain plug.
- 5) Remove all ice from the dispenser unit/ice storage bin. Clean the dispenser unit/ice storage bin using a neutral cleaner. Rinse thoroughly after cleaning.
- 6) Replace the drain plug, water shield, overflow pipe, overflow cap, cube guide A, cube guide B, splash guard, and front insulation panel in their correct positions. Be careful not to cross thread the drain plug or overflow pipe.
- 7) Replace the front panel in its correct position.

## VI. Decommissioning and Disposal



### R-290 Class A3 Flammable Refrigerant Used

#### **⚠ DANGER**

##### **Risk of Fire or Explosion. Flammable Refrigerant Used.**

- Be sure to follow all Important Safety Information located at the beginning of this manual and at the beginning of section "III.A. Safety Precautions When Servicing."
- Servicing shall be done by trained service personnel with certified competence in handling flammable refrigerants to minimize the risk of possible ignition due to improper service.
- Follow handling instructions carefully in compliance with national regulations.
- Dispose of properly in accordance with federal or local regulations.
- Do not puncture refrigerant tubing. Risk of fire or explosion due to puncture of refrigerant tubing; follow handling instructions carefully.
- When removing refrigerant from a system, either for servicing or decommissioning, it is recommended good practice that all refrigerants are removed safely.
- When transferring refrigerant into cylinders, ensure that only appropriate refrigerant recovery cylinders are employed. Ensure that the correct number of cylinders for holding the total system charge is available. All cylinders to be used are designated for the recovered refrigerant and labeled for that refrigerant (i.e., special cylinders for the recovery of refrigerant). Cylinders shall be complete with pressure-relief valve and associated shut-off valves in good working order. Empty recovery cylinders are evacuated and, if possible, cooled before recovery occurs.
- The recovery equipment shall be in good working order with a set of instructions concerning the equipment that is at hand and shall be suitable for the recovery of all appropriate refrigerants including, when applicable, flammable refrigerants. In addition, a set of calibrated weighing scales shall be available and in good working order. Hoses shall be complete with leak-free disconnect couplings and in good condition. Before using the recovery machine, check that it is in satisfactory working order, has been properly maintained and that any associated electrical components are sealed to prevent ignition in the event of a refrigerant release. Consult manufacturer if in doubt.
- The recovered refrigerant shall be returned to the refrigerant supplier in the correct recovery cylinder, and the relevant waste transfer note arranged. Do not mix refrigerants in recovery units and especially not in cylinders.
- If compressors or compressor oils are to be removed, ensure that they have been evacuated to an acceptable level to make certain that flammable refrigerant does not remain within the lubricant. The evacuation process shall be carried out prior to returning the compressor to the suppliers. Only electric heating to the compressor body shall be employed to accelerate this process. When oil is drained from a system, it shall be carried out safely.

## **⚠ DANGER Continué**

### **Risque D'Incendie ou D'Explosion. Fluide Frigorigène Inflammable Utilisé.**

- Assurez-vous de suivre toutes les informations importantes de sécurité qui se trouvent au début du présent manuel et au début de la section «III.A. Précautions de sécurité lors de l'entretien.»
- L'entretien doit être effectué par du personnel formé et certifié pour la manipulation de réfrigérants inflammables afin de réduire au minimum le risque d'inflammation dû à un entretien inadéquat.
- Suivre attentivement les instructions de manutention conformément aux règlements nationaux.
- Mettre au rebut conformément aux conformément aux règlements fédéraux ou locaux.
- Ne pas perforer la conduite de fluide frigorigène. Risque d'incendie ou d'explosion en cas de perforation d'une canalisation de fluide frigorigène; suivez attentivement les instructions de manutention.
- Lors de l'élimination du réfrigérant d'un système, que ce soit pour l'entretien ou la mise hors service, il est recommandé de veiller à ce que tous les réfrigérants soient éliminés en toute sécurité.
- Lors du transfert de réfrigérant dans des bouteilles, veillez à ce que seules des bouteilles de récupération de réfrigérant appropriées soient utilisées. Assurez-vous que le nombre de bouteilles nécessaires pour contenir la charge totale du système est disponible. Toutes les bouteilles à utiliser sont désignées pour le réfrigérant récupéré et étiquetées pour ce réfrigérant (c'est-à-dire des bouteilles spéciales pour la récupération du réfrigérant). Les bouteilles doivent être équipées d'une soupape de surpression et de soupapes d'arrêt associées en bon état de fonctionnement. Les bouteilles de récupération vides sont évacuées et, si possible, refroidies avant la récupération.
- L'équipement de récupération doit être en bon état de fonctionnement, accompagné d'un ensemble d'instructions concernant l'équipement disponible et doit être adapté à la récupération de tous les réfrigérants appropriés, y compris, le cas échéant, les réfrigérants inflammables. En outre, un ensemble de balances étalonnées doit être disponible et en bon état de fonctionnement. Les tuyaux doivent être complets, équipés de raccords de déconnexion sans fuite et en bon état. Avant d'utiliser la machine de récupération, vérifiez qu'elle est en bon état de fonctionnement, qu'elle a été correctement entretenue et que tous les composants électriques associés sont scellés pour éviter toute inflammation en cas de fuite de réfrigérant. Consulter le fabricant en cas de doute.
- Le réfrigérant récupéré doit être renvoyé au fournisseur de réfrigérant dans la bouteille de récupération appropriée et le bon de transfert de déchets correspondant doit être établi. Ne mélangez pas les réfrigérants dans les unités de récupération et surtout pas dans les bouteilles.

## **DANGER Continué**

- Si les compresseurs ou les huiles de compresseur doivent être retirés, assurez-vous qu'ils ont été évacués à un niveau acceptable afin de s'assurer qu'il ne reste pas de réfrigérant inflammable dans le lubrifiant. Le processus d'évacuation doit être effectué avant que le compresseur ne soit renvoyé aux fournisseurs. Seul le chauffage électrique du boîtier du compresseur doit être utilisé pour accélérer ce processus. Lorsque l'huile est vidangée d'un système, cette opération doit être effectuée en toute sécurité.

The appliance contains refrigerant and must be disposed of in accordance with applicable national, state, and local codes and regulations. Refrigerant must be recovered and safely disposed of by properly trained service personnel.

Before carrying out this procedure, it is essential that the technician is completely familiar with the equipment and all its detail. It is recommended good practice that all refrigerants are recovered safely. Prior to the task being carried out, an oil and refrigerant sample shall be taken in case analysis is required prior to re-use of recovered refrigerant. It is essential that electrical power is available before the task is commenced.

- Become familiar with the equipment and its operation.
- Isolate the system electrically.
- **Before attempting the procedure, ensure that:**
  - mechanical handling equipment is available, if required, for handling refrigerant cylinders
  - all personal protective equipment is available and being used correctly
  - the recovery process is supervised at all times by a competent person
  - recovery equipment and cylinders conform to the appropriate standards
- Pump down refrigerant system, if possible.
- If a vacuum is not possible, make a manifold so that refrigerant can be removed from various parts of the system.
- Make sure that cylinder is situated on the scales before recovery takes place.
- Start the recovery machine and operate in accordance with instructions.
- Do not overfill cylinders (no more than 80% volume liquid charge).
- Do not exceed the maximum working pressure of the cylinder, even temporarily.
- When the cylinders have been filled correctly and the process completed, make sure that the cylinders and the equipment are removed from site promptly and all isolation valves on the equipment are closed off.
- Recovered refrigerant shall not be charged into another refrigerating system unless it has been cleaned and checked.

**Follow the steps below for decommissioning and disposal:**

**1. Recovery**

- 1) Recover the refrigerant, and safely dispose of the refrigerant.
- 2) Evacuate the appliance.
- 3) Purge the refrigeration system with nitrogen.
- 4) Cut out the compressor and drain and dispose of the compressor oil. Compressor oils are to be removed, ensure that they have been evacuated to an acceptable level to make certain that flammable refrigerant does not remain within the lubricant. Dispose of compressor and compressor oil in compliance with national, state, and local codes and regulations.
- 5) Purge the refrigeration system with nitrogen.

**2. Labeling**

Equipment shall be labeled stating that it has been de-commissioned and emptied of refrigerant. The label shall be dated and signed. For appliances containing flammable refrigerant, ensure that there are labels on the equipment stating the equipment contains flammable refrigerant.

## VII. Technical Information

We reserve the right to make changes in specifications and design without prior notice.

### A. Specification and Performance Data Sheets

Pressure data is recorded at 5 min. into freezing cycle. The data not in bold should be used for reference only.

#### 1. KM-830MAK2

##### Specification Sheet

AC SUPPLY VOLTAGE (V/Hz/PH)	~208-230/60/1	
AMPERAGE (A)	6.4	
MINIMUM CIRCUIT AMPACITY (A)	20	
MAXIMUM FUSE SIZE (A)	20	
ELECTRIC & WATER CONSUMPTION Air/Wtr °F (°C)	90/70 (32/21)	70/50 (21/10)
ELECTRIC W (kWH/100 lb)	1110 (4.4)	1030 (3.17)
WATER gal./24HR (gal./100 lb)	190.5 (30)	339.8 (44)
SHAPE OF ICE	CRESCENT - 13x6x4	
ICE PRODUCTION PER CYCLE # pieces @ lb (kg)	624 pieces @ 14.2 (6.4)	
HARVEST RATE (lb/day)	≤1000	
ICE MAKING SYSTEM	Float Switch	
HARVESTING SYSTEM	Hot Gas and Water, Thermistor and Timer	
ICE MAKING WATER CONTROL	Timer Controlled. Overflow Pipe	
BIN CONTROL SYSTEM	Mechanical Lever Switch	
REFRIGERANT CHARGE g (oz.)	R-290, 309 (10.9)	
FOAM BLOWING AGENT	HFO 1233zd(E)	
DESIGN PRESSURE kPaG (PSIG)	HI-2027 (294) LO-897 (130)	

##### Performance Data

APPROXIMATE ICE PRODUCTION	AMBIENT	WATER TEMP. (°F/°C)					
		50/10		70/21		90/32	
	70/21	<b>777</b>	<b>352</b>	735	334	675	306
	80/27	745	338	681	309	618	281
	90/32	735	334	<b>635</b>	<b>288</b>	572	260
lbs./day kg./day	100/38	722	328	620	281	<b>515</b>	<b>233</b>
APPROXIMATE ELECTRIC CONSUMPTION	70/21	<b>1030</b>		1053		1096	
	80/27	1048		1084		1133	
	90/32	1053		<b>1110</b>		1157	
watts	100/38	1065		1121		<b>1200</b>	
APPROXIMATE WATER CONSUMPTION PER 24 HR.	70/21	<b>340</b>	<b>1.29</b>	296	1.12	264	1.00
	80/27	306	1.16	239	0.90	222	0.84
	90/32	296	1.12	<b>191</b>	<b>0.72</b>	167	0.63
gal./day m3/day	100/38	242	0.92	185	0.70	<b>145</b>	<b>0.55</b>
FREEZING CYCLE TIME	70/21	<b>24.0</b>		25.6		29.0	
	80/27	25.2		27.7		31.8	
	90/32	25.6		<b>29.4</b>		33.3	
min.	100/38	26.7		30.3		<b>36.8</b>	
HARVEST CYCLE TIME	70/21	<b>2.9</b>		2.7		2.6	
	80/27	2.7		2.4		2.5	
	90/32	2.7		<b>2.2</b>		2.2	
min.	100/38	2.5		2.2		<b>2.2</b>	
HEAD PRESSURE	70/21	<b>164</b>	<b>11.5</b>	180	12.7	201	14.2
	80/27	177	12.4	202	14.2	222	15.6
	90/32	180	12.7	<b>220</b>	<b>15.5</b>	241	16.9
PSIG kg/cm2G	100/38	184	12.9	225	15.8	<b>260</b>	<b>18.3</b>
SUCTION PRESSURE	70/21	<b>40</b>	<b>2.8</b>	41	2.9	43	3.0
	80/27	41	2.9	43	3.0	44	3.1
	90/32	41	2.9	<b>44</b>	<b>3.1</b>	46	3.2
PSIG kg/cm2G	100/38	41	2.9	44	3.1	<b>47</b>	<b>3.3</b>
TOTAL HEAT OF REJECTION FROM CONDENSER	9,500 BTU/h [AT 90°F (32°C) / WT 70°F (21°C)]						
TOTAL HEAT OF REJECTION FROM COMPRESSOR	1,400 BTU/h [AT 90°F (32°C) / WT 70°F (21°C)]						

# B. Wiring Diagram

COMPRESSOR CAPACITOR TABLE

MODEL	START CAP	RUN CAP
KM-830MAK2	108-130 MFD	20MFD

S4 DIP SWITCH SETTING

MODEL	1	2	3	4	5	6	7	8	9	10
KM-830MAK2	OFF	OFF	OFF	OFF	OFF	OFF	ON	OFF	OFF	OFF

S5 DIP SWITCH SETTING

MODEL	1	2	3	4	5
KM-830MAK2	OFF	OFF	ON	OFF	ON

- WIRE COLOR CODE
- BK BLACK
  - BR BROWN
  - DBU DARK BLUE
  - GR GREEN
  - GY GRAY
  - O ORANGE
  - P PINK
  - R RED
  - V VIOLET
  - W WHITE
  - Y YELLOW
  - W/BU WHITE/BLUE
  - W/R WHITE/RED

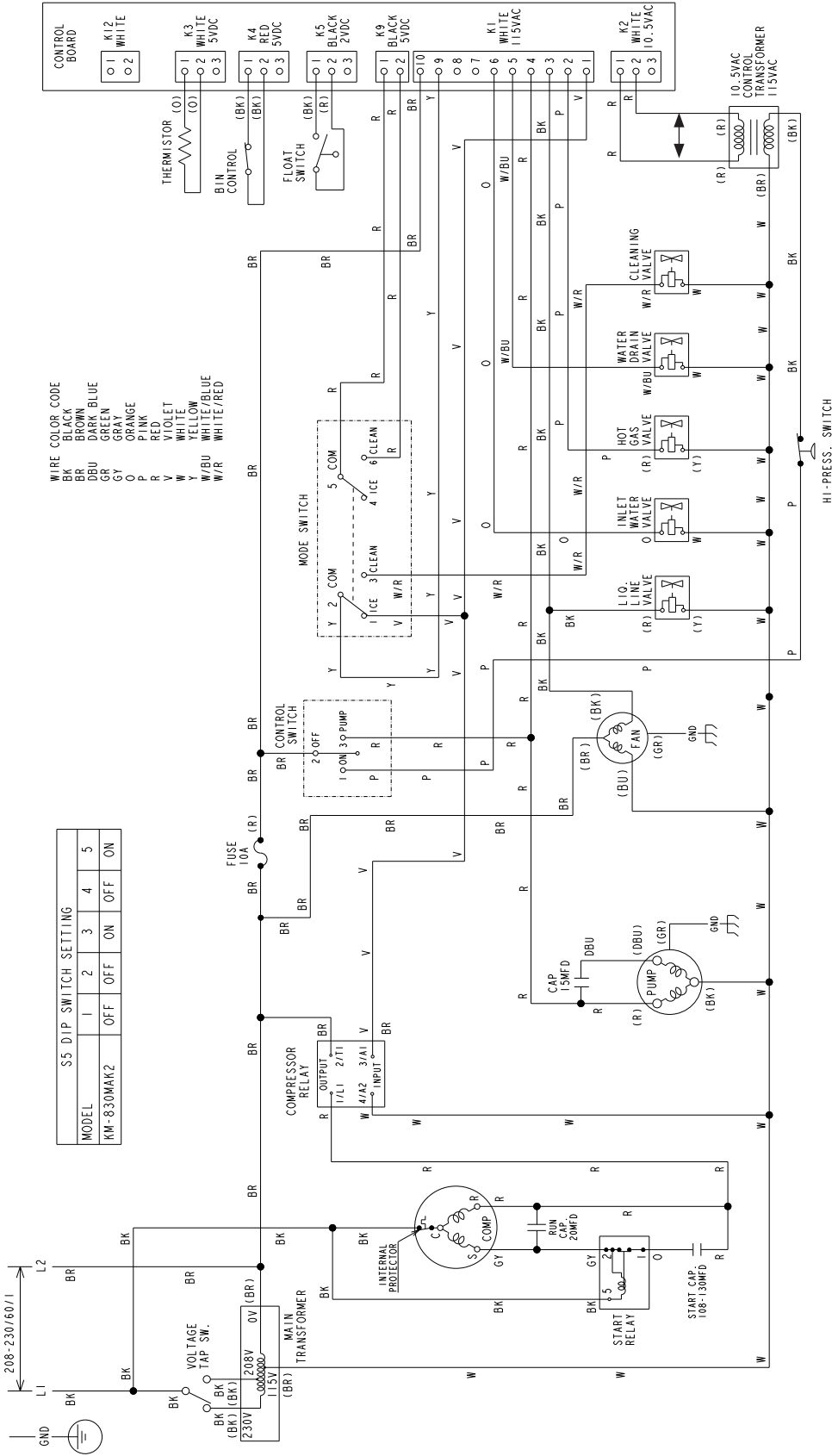

High-Pressure Switch

Cut-out	360± <sup>30</sup> <sub>0</sub> PSIG
Cut-in	249±10 PSIG