



HOSHIZAKI

Service Manual

Refrigerated Kitchen Equipment
Steelheart B Series

Models
Undercounter
Worktop
Prep Table

Auxiliary Codes P-6 and Later



hoshizakiamerica.com

Number: 73266
Issued: 11-14-2025
Revised: 5-26-2026

⚠ WARNING

Only qualified service technicians should install and service the appliance. To obtain the name and phone number of your local Hoshizaki Certified Service Representative, visit www.hoshizakiamerica.com. No service should be undertaken until the technician has thoroughly read this Service Manual. Failure to service and maintain the appliance in accordance with this manual will adversely affect safety, performance, component life, and warranty coverage. Proper installation is the responsibility of the installer. Product failure or property damage due to improper installation is not covered under warranty.

Hoshizaki provides this manual primarily to assist qualified service technicians in the service of the appliance.

Should the reader have any questions or concerns which have not been satisfactorily addressed, please call, send an e-mail message, or write to the Hoshizaki Technical Support Department for assistance.

Phone: 1-800-233-1940; (770) 487-2331

E-mail: tech-support@hoshizaki.com

HOSHIZAKI AMERICA, INC.

618 Highway 74 South

Peachtree City, GA 30269

Attn: Hoshizaki Technical Support Department

NOTE: To expedite assistance, all correspondence/communication **MUST** include the following information:

- Model Number _____
- Serial Number _____
- Complete and detailed explanation of the problem.

IMPORTANT

This manual should be read carefully before the appliance is serviced. Read the warnings and guidelines contained in this manual carefully as they provide essential information for the continued safe use, service, and maintenance of the appliance. Retain this manual for any further reference that may be necessary.

CONTENTS

Important Safety Information	4
I. Construction and Refrigeration Circuit Diagram	10
A. Construction	10
B. Refrigeration Circuit Diagram	12
II. Sequence of Operation Flow Charts	13
1. UR/WR: Refrigerator	13
2. SR: Refrigerator	14
3. UF/WF: Freezer	15
III. Service Diagnosis, Refrigeration Circuit Service, and Component Service	16
A. Safety Precautions When Servicing Précautions à prendre lors de l'entretien	16
1. English	16
2. Français	21
B. Service Diagnosis	26
C. Control Module Check	32
D. Thermistor Check	35
E. Diagnostic Table	36
F. Controls and Adjustments	39
G. Defrost	40
H. Safety Devices	41
I. Perimeter and Mullion Heaters (UF/WF only)	41
IV. Refrigeration Circuit and Component Service Information	42
A. Refrigeration Circuit Service Information	44
B. Component Service Information	48
V. Maintenance	50
VI. Preparing the Appliance for Periods of Non-Use	51
VII. Disposal and Decommissioning	52
VIII. Technical Information	53
A. Electrical and Refrigerant Data	53
1. Freezers	55
B. Wiring Diagrams	56
1. UR/WR27 (Glass Door), UR/WR36, UR/WR48, and SR36	56
2. UR/WR60, UR/WR72, UR48 (Glass Door)	57
3. UF/WF27 (Glass Door), SR27, and SR48	58
4. UF/WF48, UF/WF60, SR60, and SR72	59

Important Safety Information

Throughout this manual, notices appear to bring your attention to situations which could result in death, serious injury, damage to the appliance, or damage to property.

	<h3>R-290 Class A3 Flammable Refrigerant Used</h3>
⚠ DANGER	Indicates a hazardous situation that, if not avoided, will result in death or serious injury.
⚠ WARNING	Indicates a hazardous situation that, if not avoided, could result in death or serious injury.
NOTICE	Indicates a situation that, if not avoided, could result in damage to the appliance or property.
IMPORTANT	Indicates important information about the use and care of the appliance.
⚠ DANGER	
<p><u>Risk of Fire or Explosion</u> <u>Flammable Refrigerant Used</u></p> <ul style="list-style-type: none"> • Only qualified service technicians should install and service the appliance. Qualified service technicians are those having the appropriate technical training and experience necessary to be aware of hazards to which they are exposed in performing a task and of measures necessary to minimize the danger to themselves or other persons. • No service should be undertaken until the technician has thoroughly read this Service Manual. All safety precautions must be followed. • This appliance to be installed in accordance with the Safety Standard for Refrigeration Systems ANSI/ASHRAE 15. • Follow handling instructions carefully in compliance with national regulations. • Do not use mechanical devices or other means to accelerate the defrosting process or to clean, other than those recommended by the manufacturer. • Do not puncture refrigerant tubing. Risk of fire or explosion due to puncture of refrigerant tubing; follow handling instructions carefully. 	<ul style="list-style-type: none"> • Servicing shall be done by trained service personnel with certified competence in handling flammable refrigerants to minimize the risk of possible ignition due to incorrect parts or improper service. • Component parts shall be replaced with like components. So as to minimize the risk of possible ignition due to incorrect parts. • Dispose of properly in accordance with federal or local regulations. • Do not pierce or burn. • Be aware that refrigerants may not contain an odor. • Do not damage the refrigeration circuit. • See nameplate for R-290 refrigerant charge: <ul style="list-style-type: none"> • If greater than 114 g (4 oz.), do not install in public corridor or lobby. • If greater than 152 g (5.3 oz.), do not install within 6 m (20 ft) of open flame. • The appliance shall be stored in a room without continuously operating ignition sources (for example: open flames, an operating gas appliance, or an operating electric heater).

⚠ DANGER continued

- Do not place any potential ignition sources in or near the appliance.
- Keep clear of obstruction all ventilation openings in the appliance enclosure or in the structure for building-in.
- No potential sources of ignition are to be used in the searching for or detection of refrigerant leaks.
- Do not use electrical appliances inside the appliance unless they are of the type recommended by the manufacturer.
- Do not store explosive substances such as aerosol cans with a flammable propellant in this appliance.
- Check that cabling will not be subject to wear, corrosion, excessive pressure, vibration, sharp edges, or any other adverse environmental effects. The check shall also take into account the effects of aging or continual vibration from sources such as compressors or fans.
- Ensure that the area is in the open or that it is adequately ventilated before breaking into the system or conducting any hot work. A degree of ventilation shall continue during the period that the work is carried out. The ventilation should safely disperse any released refrigerant and preferably expel it externally into the atmosphere.

Risque D'Incendie ou D'Explosion
Fluide Frigorigène Inflammable Utilisé

- Seuls des techniciens de service qualifiés doivent installer et entretenir l'appareil. Les techniciens de service qualifiés sont ceux qui possèdent la formation technique et l'expérience nécessaires pour être conscients des dangers auxquels ils sont exposés dans l'accomplissement d'une tâche et des mesures nécessaires pour réduire au minimum le danger pour eux-mêmes ou pour d'autres personnes.
- Aucune opération d'entretien ne doit être entreprise avant que le technicien n'ait lu attentivement ce manuel. Toutes les précautions de sécurité doivent être suivies.
- Cet appareil doit être installé conformément à la norme de sécurité pour les systèmes de réfrigération ANSI/ASHRAE 15.
- Suivez attentivement les instructions de manutention conformément aux règlements nationaux.
- Ne pas utiliser de dispositifs mécaniques ou d'autres moyens pour accélérer le processus de dégivrage ou pour nettoyer, autres que ceux recommandés par le fabricant.
- Ne pas perforer la conduite de fluide frigorigène. Risque d'incendie ou d'explosion en cas de perforation d'une canalisation de fluide frigorigène; suivez attentivement les instructions de manutention.
- L'entretien doit être effectué par du personnel formé et certifié pour la manipulation de réfrigérants inflammables afin de réduire au minimum le risque d'inflammation dû à des pièces incorrectes ou à un entretien inadéquat.
- Les pièces doivent être remplacées par des pièces similaires, de manière à réduire au minimum le risque d'inflammation dû à des pièces incorrectes.

DANGER Continué

- Mettre au rebut conformément aux règlements fédéraux ou locaux.
 - Ne pas percer ou brûler.
 - Attention, les fluides frigorigènes peuvent ne pas dégager d'odeur.
 - Ne pas endommager les composants du circuit de réfrigération.
 - Voir plaque signalétique pour la charge de réfrigérant R-290:
 - Si elle est supérieure à 114 g (4 oz.), ne pas l'installer dans un couloir public ou un hall d'entrée.
 - Si elle est supérieure à 152 g (5.3 oz.), ne pas l'installer à moins de 6 m (20 pi) d'une flamme nue.
 - L'appareil doit être entreposé dans un local ne contenant pas de sources d'inflammation permanentes (flammes nues, appareil à gaz ou dispositif de chauffage électrique en fonctionnement, par exemple).
 - Ne placer aucune source d'inflammation potentielle à l'intérieur ou à proximité de l'appareil.
 - Ne pas obstruer les ouvertures de ventilation dans l'enceinte de l'appareil ou dans la structure d'encastrement.
 - Aucune source potentielle d'inflammation ne doit être utilisée pour rechercher ou détecter des fuites de réfrigérant.
 - Ne pas utiliser d'appareils électriques à l'intérieur de l'appareil, sauf s'ils sont du type recommandé par le fabricant.
 - Ne pas entreposer dans cet appareil des substances explosives telles que des bombes aérosols contenant un gaz propulseur inflammable.
- Vérifier que le câblage ne sera pas soumis à l'usure, à la corrosion, à une pression excessive, à des vibrations, à des arêtes vives ou à tout autre effet environnemental négatif. Le contrôle doit également prendre en compte les effets du vieillissement ou des vibrations continues provenant de sources telles que les compresseurs ou les ventilateurs.
 - S'assurer que la zone est à l'air libre ou qu'elle est correctement ventilée avant de pénétrer dans le système ou d'effectuer un travail à chaud. Une certaine ventilation doit être maintenue pendant la durée des travaux. La ventilation doit permettre de disperser en toute sécurité tout réfrigérant libéré et, de préférence, de l'expulser dans l'atmosphère.

WARNING

The appliance should be destined only to the use for which it has been expressly conceived. Any other use should be considered improper and therefore dangerous. The manufacturer cannot be held responsible for injury or damage resulting from improper, incorrect, and unreasonable use. Failure to service and maintain the appliance in accordance with this manual will adversely affect safety, performance, component life, and warranty coverage and may result in costly water damage.

To reduce the risk of death, electric shock, serious injury, or fire, follow basic precautions including the following:

- This appliance is not intended for use above 2,000 m (6,561 ft). Installation above 2,000 m (6,561 ft) may adversely affect safety, performance, and component life.
 - Wear appropriate personal protective equipment (PPE) when servicing the appliance.
 - The appliance must be installed in accordance with applicable national, state, and local codes and regulations. Failure to meet these code requirements could result in death, electric shock, serious injury, fire, or damage.
 - The appliance requires an independent power supply of proper capacity. See the nameplate for electrical specifications. Failure to use an independent power supply of proper capacity can result in a tripped breaker, blown fuse, damage to existing wiring, or component failure. This could lead to heat generation or fire.
 - Do not make any alterations to the appliance. Alterations could result in electric shock, injury, fire, or damage to the appliance.
- **THE APPLIANCE MUST BE GROUNDED.** The appliance is equipped with a NEMA 5-15 three-prong grounding plug  to reduce the risk of potential shock hazards. It must be plugged into a properly grounded, independent 3-prong wall outlet. If the outlet is a 2-prong outlet, it is your personal responsibility to have a qualified electrician replace it with a properly grounded, independent 3-prong wall outlet. Do not remove the ground prong from the power cord and do not use an adapter plug. Failure to follow these instructions may result in death, electric shock, or fire.
 - To reduce the risk of electric shock, do not touch the control module with damp hands.
 - To reduce the risk of electric shock, make sure the control module is in the "OFF" position before plugging in or unplugging the appliance.
 - Unplug the appliance before servicing.
 - Do not use an appliance with a damaged power cord. The power cord should not be altered, jerked, bundled, weighed down, pinched, or tangled. Such actions could result in electric shock or fire. To unplug the appliance, be sure to pull the plug, not the cord, and do not jerk the cord.
 - Do not use an extension cord.
 - If the supply cord is damaged, it must be replaced by the manufacturer, its service agent, or similarly qualified persons in order to avoid a hazard. Upon replacement, the GREEN ground wire in the power cord must be connected to the designated grounding screw.
 - Appliance is heavy. Use care when lifting or positioning. Work in pairs when needed to prevent injury or damage.

⚠ WARNING continued

- The appliance is not intended for use by persons (including children) with reduced physical, sensory, or mental capabilities, or lack of experience and knowledge, unless they have been given supervision or instruction concerning use of the appliance by a person responsible for their safety.
- Do not splash, pour, or spray water directly onto or into the appliance. This might cause short circuit, electric shock, corrosion, or failure.
- Children should be supervised to ensure that they do not play with the appliance.
- Do not climb, stand, or hang on the appliance or drawers or allow children or animals to do so. Do not climb into the appliance or allow children or animals to do so. Death or serious injury could occur or the appliance could be damaged.
- Open and close the door with care. Door opened too quickly or forcefully may cause injury or damage to the appliance or surrounding equipment.
- Be careful not to pinch fingers when opening and closing the door. Be careful when opening and closing the door when children are in the area.
- Do not use combustible spray or place volatile or flammable substances in or near the appliance. They might catch fire.
- Keep the area around the appliance clean. Dirt, dust, or insects in the appliance could cause harm to individuals or damage to the appliance.

Additional Warnings for SR Models

- The entire rail must always be covered by rail dividers and pans (1/6 size, up to 6" (15 cm) deep). Otherwise, the appliance will not cool properly.
- Use only 1/6 size pans up to 6" (15 cm) deep. Do not use damaged pans.
- Ingredients must be pre-chilled to 37°F (3°C) or less before placing in rail.
- Keep the rail cover closed when not actively preparing food.
- The rail is for keeping ingredients cool while preparing food. If not actively preparing food for a long period such as overnight, seal pans with plastic wrap in addition to closing the rail cover. Depending on conditions, the cabinet temperature setting may need to be adjusted to prevent items from freezing. Alternatively, seal ingredients and store them in a refrigerator or freezer.

NOTICE

- Install the appliance in a location that stays above freezing. Normal operating ambient temperature must be within 45°F to 100°F (7°C to 38°C).
- Do not leave the appliance on during extended periods of non-use, extended absences, or in sub-freezing temperatures. To properly prepare the appliance for these occasions, follow the instructions in "VI. Preparing the Appliance for Periods of Non-Use."
- Keep ventilation openings, in the appliance enclosure or in the built-in structure, clear of obstruction. Do not place anything on top of the appliance in an undercounter installation. There must be at least 1.5" (4 cm) overhead clearance for proper ventilation. The factory-installed rear bumpers must be in place to ensure proper rear clearance. Blockage of airflow could negatively affect performance and damage the appliance.
- Do not allow the appliance to bear any outside weight.
- To prevent deformation or cracks, do not spray insecticide onto the plastic parts or let them come into contact with oil.
- To avoid damage to the gasket, use only the door/drawer handle when opening and closing.
- To avoid damage to the top seal, do not lift the appliance by the top panel or remove the top panel.
- Do not place objects on top of the appliance.
- Protect the floor when moving the appliance to prevent damage to the floor.
- Do not allow the appliance to bear any outside weight.

NOTICE Continued

Additional Notice for SR Models

- Do not place anything on top of the rail hood or rail cover and do not lift the appliance by the rail hood or rail cover. The rail hood and rail cover are not designed to bear any outside weight.

I. Construction and Refrigeration Circuit Diagram

A. Construction

1. Solid Door Models

- Evaporator
- Evaporator Fan
- Evaporator Fan Shroud

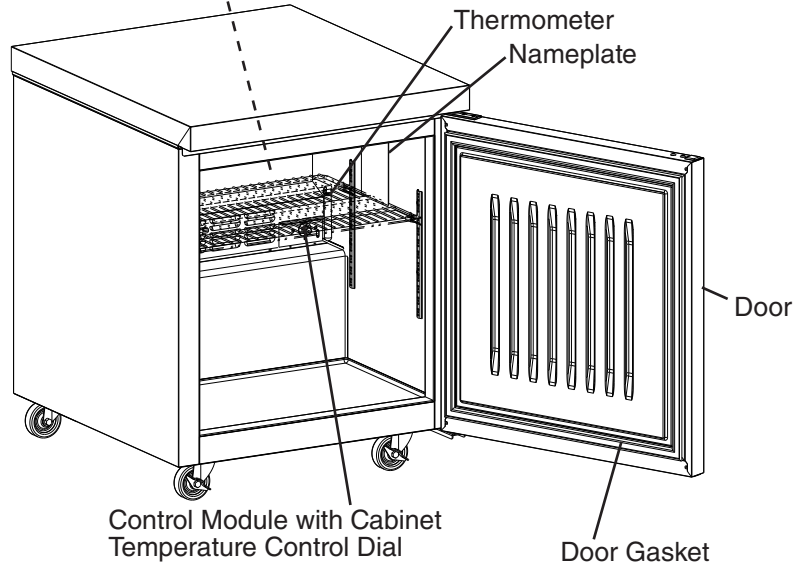

Model Shown: UR27B

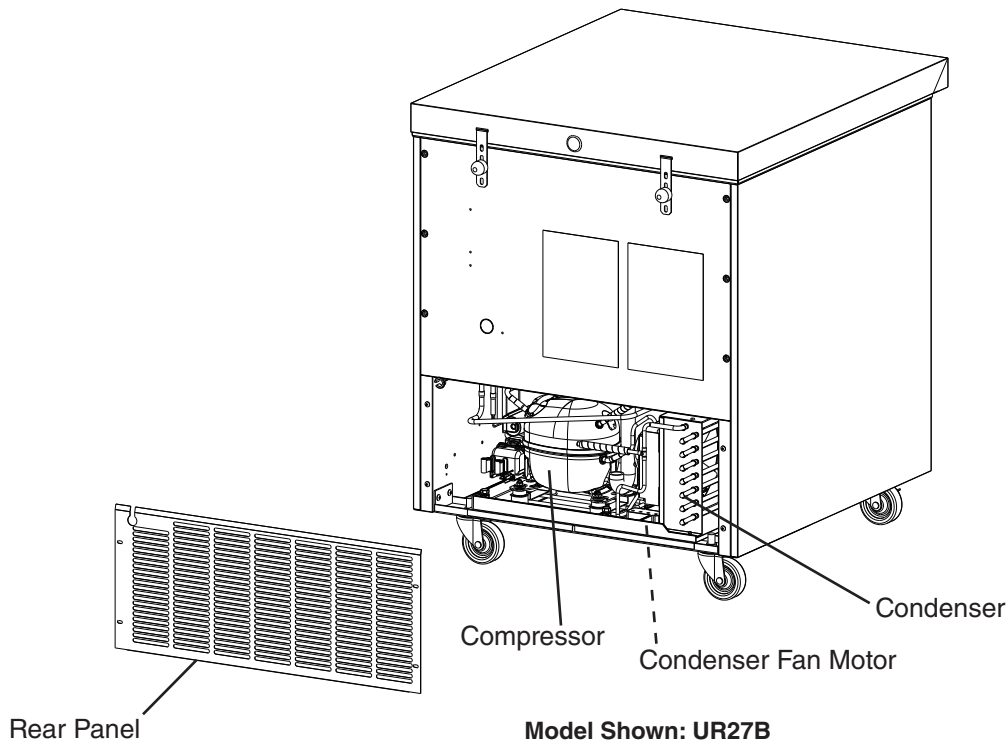

Model Shown: UR27B

2. Glass Door Models

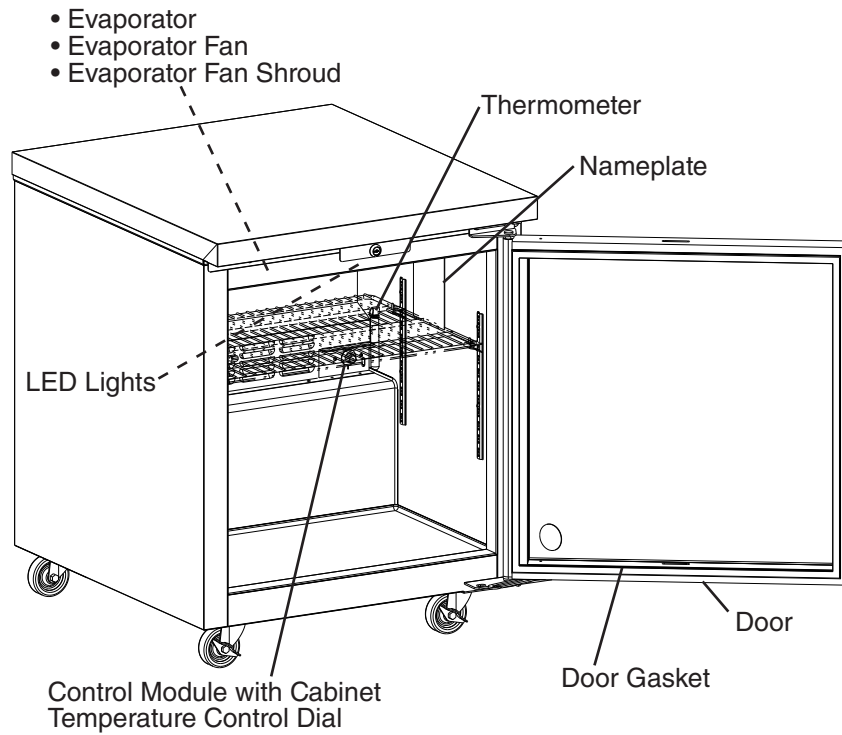

Model Shown: UR27B-GLP01

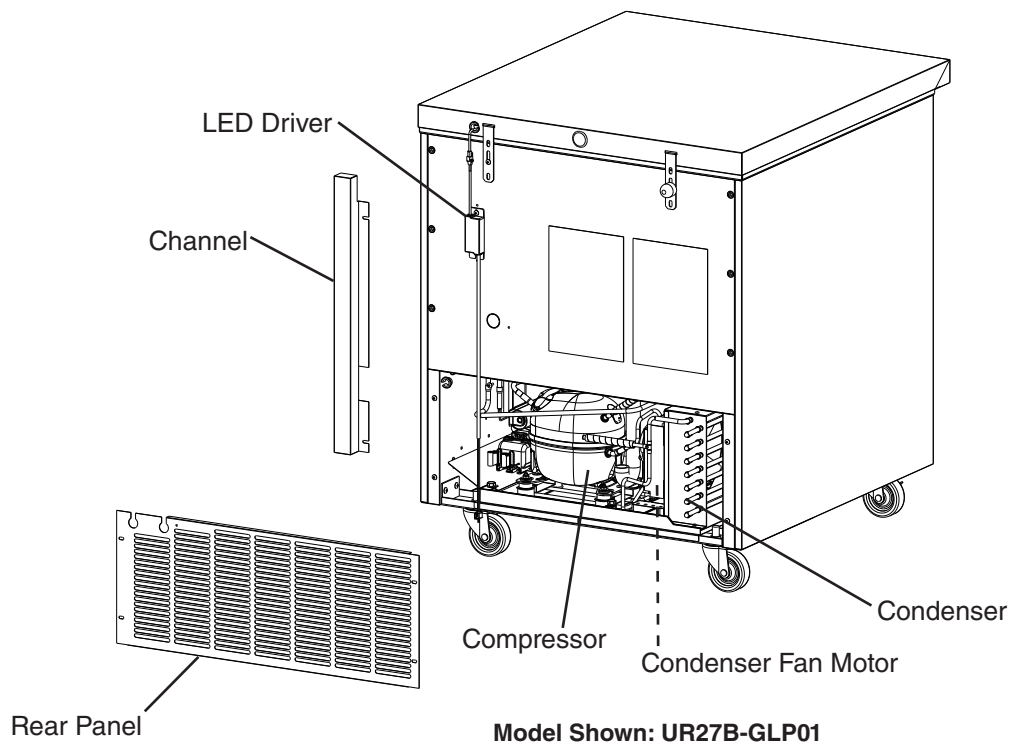

Model Shown: UR27B-GLP01

B. Refrigeration Circuit Diagram

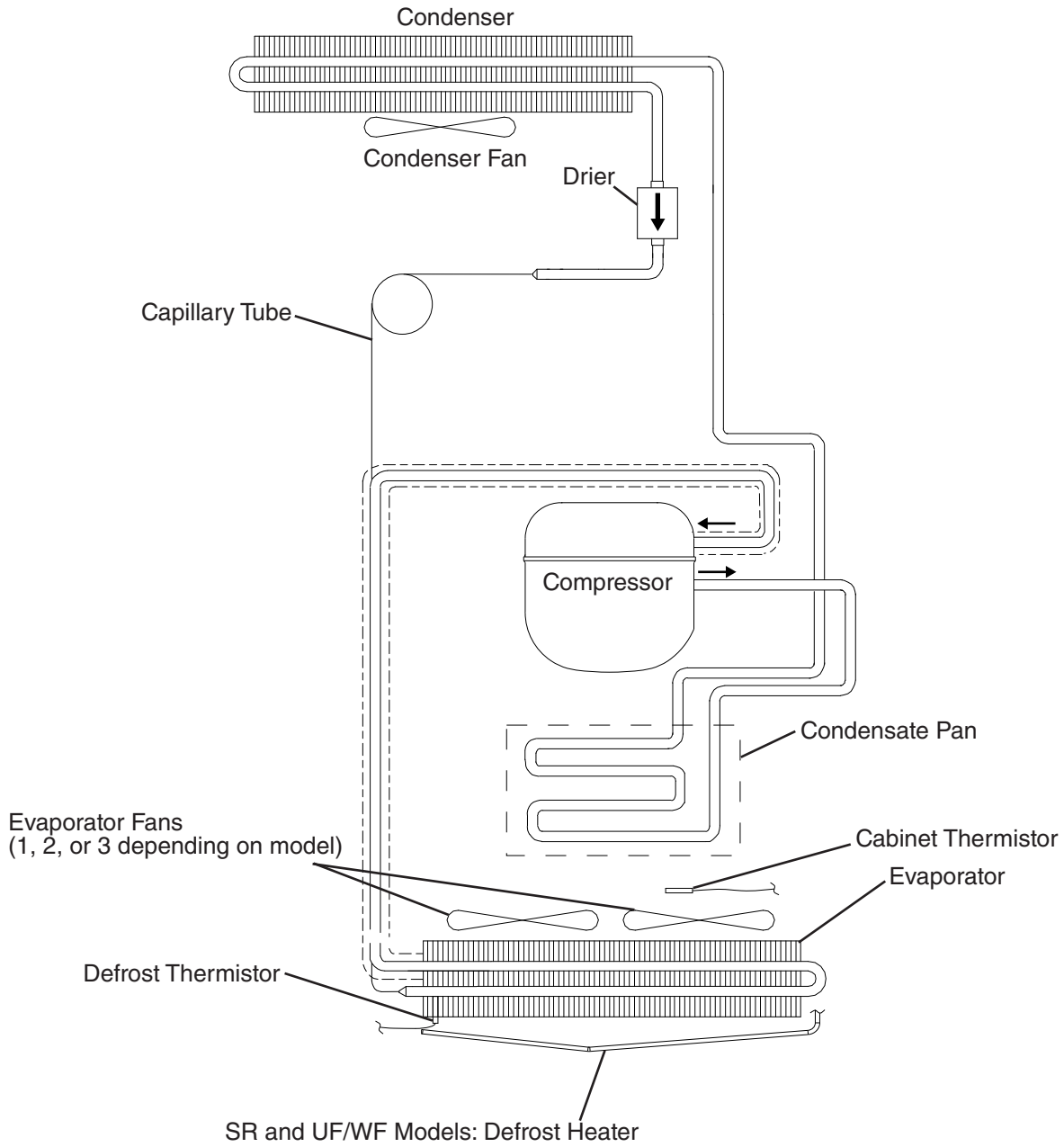

II. Sequence of Operation Flow Charts

The steps in the sequence are as outlined below.

1. UR/WR: Refrigerator

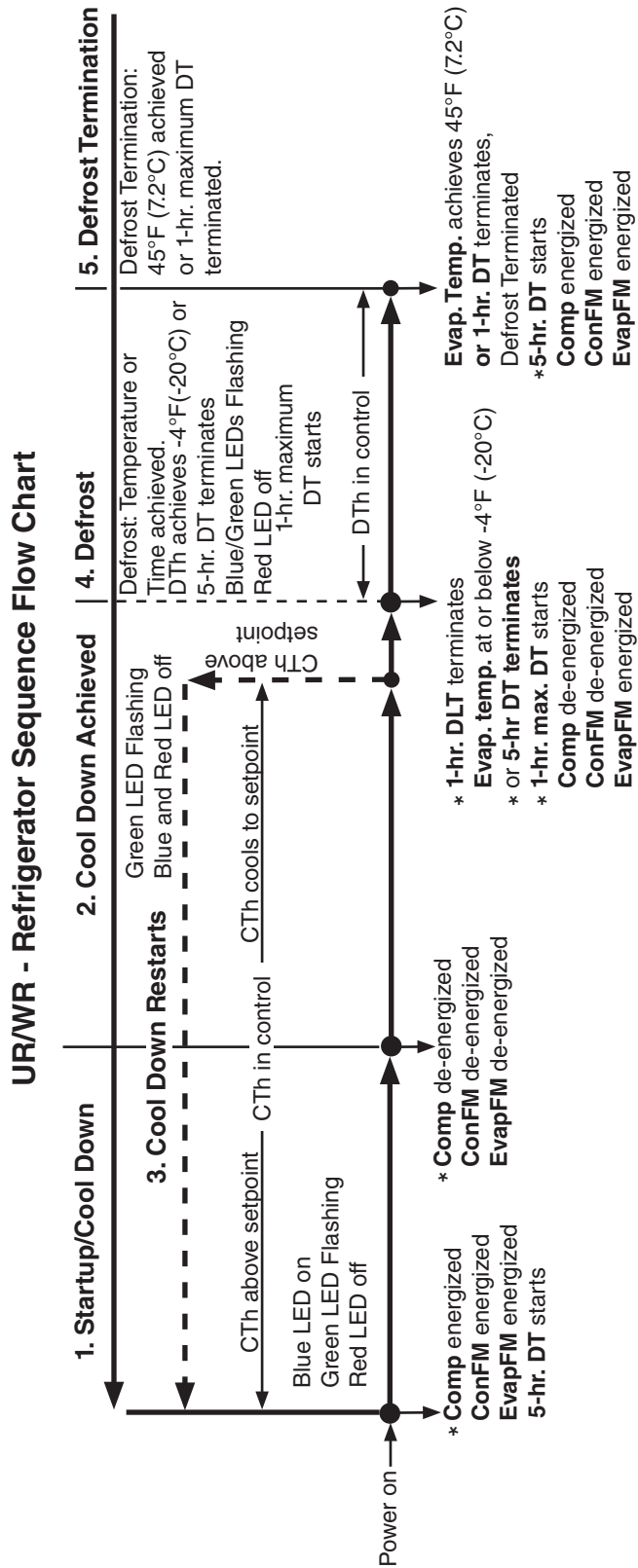

Note: *

- a) 2-min. minimum Comp on timer starts when Comp energizes
- b) 2-min. minimum Comp off timer starts when Comp de-energizes
- c) 5-hr. cumulative compressor run-time defrost timer
- d) 1-hr. maximum defrost time

Legend:

Comp-compressor
 ConFM-condenser fan motor
 CTh-cabinet thermistor
 DLT-defrost lockout timer
 DT-defrost timer (cumulative)
 DTh-defrost thermistor
 EvapFM-evaporator fan motor

2. SR: Refrigerator

SR - Refrigerator Sequence Flow Chart

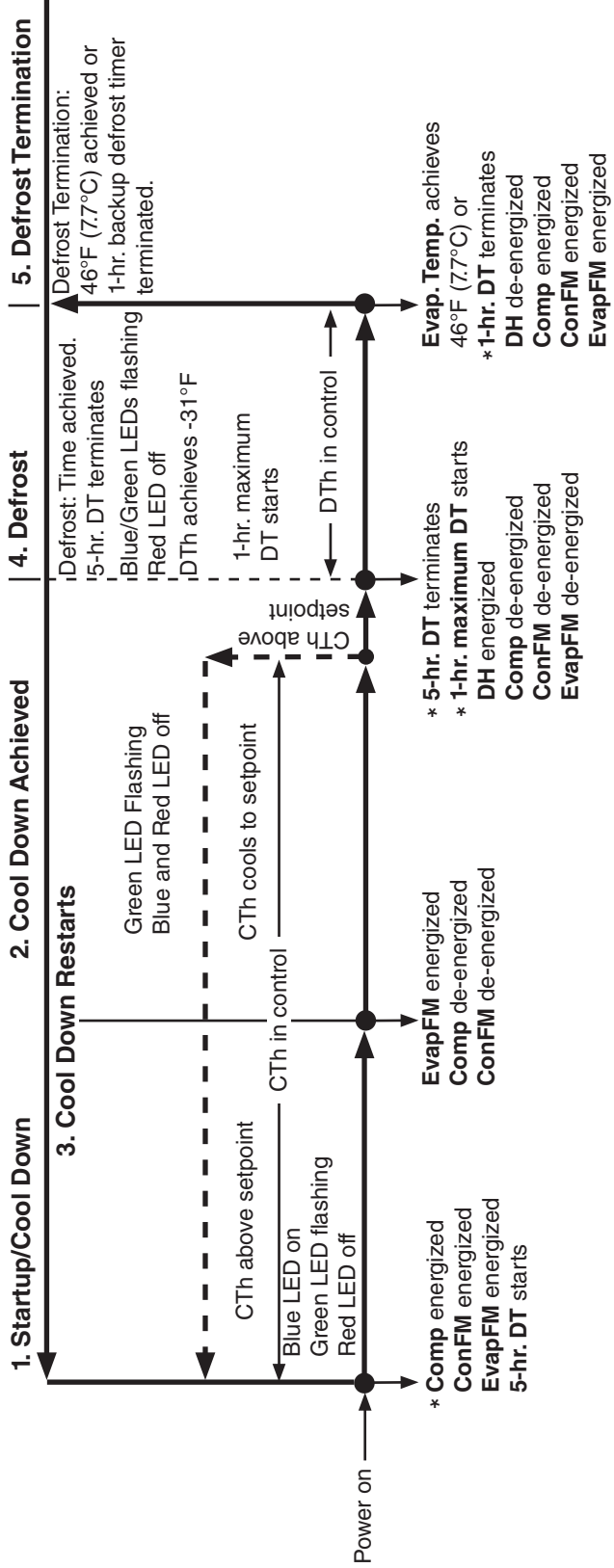

Note: *

- a) 2-min. minimum Comp on timer starts when Comp energizes
- b) 2-min. minimum Comp off timer starts when Comp de-energizes
- c) 5-hr. cumulative compressor run-time defrost timer
- d) 1-hr. maximum defrost time

Legend:
Comp -compressor
ConFM -condenser fan motor
CTh -cabinet thermistor
DH -defrost heater
DT -defrost timer
DTh -defrost thermistor
EvapFM -evaporator fan motor

3. UF/WF: Freezer

UF/WF - Freezer Sequence Flow Chart

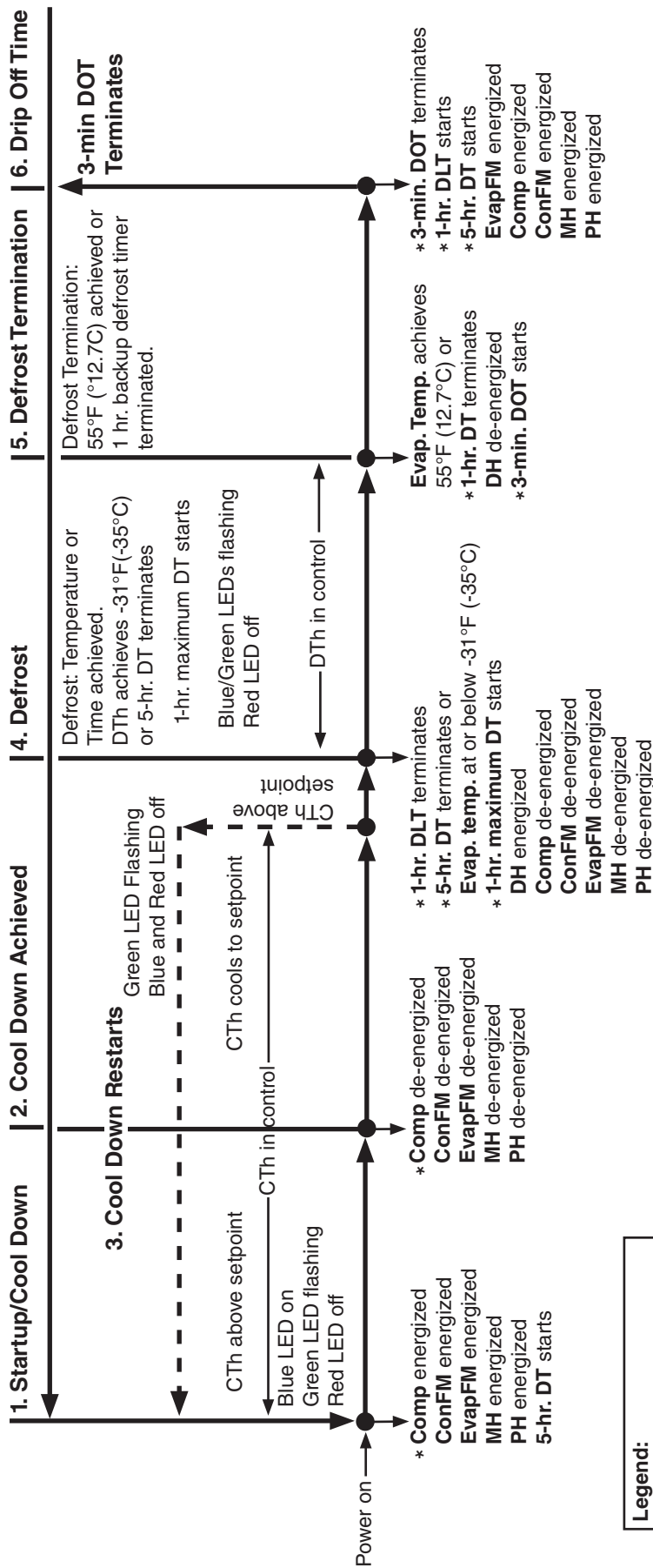

Note: *

- a) 2-min. minimum Comp on timer starts when Comp energizes
- b) 3-min. minimum Comp off timer starts when Comp de-energizes
- c) 1-hr. maximum defrost time
- d) 3-min. Comp/ConFM delay timer starts when defrost termination temperature is met (drip off time (DOT))
- e) 3-min. EvapFM delay timer terminates or DTh reaches 10°F (-12°C) (FDD (fan delay after defrost), then evaporator fan motor energizes.

Legend:
Comp-compressor
ConFM-condenser fan motor
CTh-cabinet thermistor
DH-defrost heater
DLT-defrost lock-out timer
DT-defrost timer
DTh-defrost thermistor
EvapFM-evaporator fan motor
FDD-fan delay after defrost
MH-mullion heater
PH-perimeter heater

III. Service Diagnosis, Refrigeration Circuit Service, and Component Service

A. Safety Precautions When Servicing | Précautions à prendre lors de l'entretien

1. English



R-290 Class A3 Flammable Refrigerant Used

⚠ DANGER

Risk of Fire or Explosion. Flammable Refrigerant Used.

- Be sure to follow all Important Safety Information located at the beginning of this manual and in this section.
- The appliance should be diagnosed and repaired only by qualified service personnel to reduce the risk of death, electric shock, serious injury, or fire.
- Servicing shall be done by trained service personnel with certified competence in handling flammable refrigerants to minimize the risk of possible ignition due to incorrect parts or improper service.
- Follow handling instructions carefully in compliance with national regulations.
- Do not use mechanical devices or other means to accelerate the defrosting process or to clean, other than those recommended by the manufacturer.
- Be aware that refrigerants may not contain an odor.
- Do not puncture refrigerant tubing. Risk of fire or explosion due to puncture of refrigerant tubing; follow handling instructions carefully.
- Component parts shall be replaced with like components. So as to minimize the risk of possible ignition due to incorrect parts.
- Do not place any potential ignition sources in or near the appliance.
- Prior to beginning work on systems containing flammable refrigerants, safety checks are necessary to ensure that the risk of ignition is minimized.
- All maintenance staff and others working in the local area shall be instructed on the nature of work being carried out. Work in confined spaces shall be avoided.
- Work shall be undertaken under a controlled procedure so as to minimize the risk of a flammable gas or vapor being present while the work is being performed.
- The area shall be checked with an appropriate refrigerant detector prior to and during work, to ensure the technician is aware of potentially toxic or flammable atmospheres.
- Ensure that the leak detection equipment being used is suitable for use with all applicable refrigerants, i.e., nonsparking, adequately sealed, or intrinsically safe.
NOTE: The use of silicone sealant can inhibit the effectiveness of some types of leak detection equipment.
- Under no circumstances shall potential sources of ignition be used in the searching for or detection of refrigerant leaks. A halide torch (or any other detector using a naked flame) shall not be used.

⚠ DANGER continued

- The following leak detection methods are deemed acceptable for all refrigerant systems:
 - Electronic leak detectors may be used to detect refrigerant leaks but, in the case of flammable refrigerants, the sensitivity might not be adequate, or might need recalibration. (Detection equipment shall be calibrated in a refrigerant-free area.) Ensure that the detector is not a potential source of ignition and is suitable for the refrigerant used. Leak detection equipment shall be set at a percentage of the LFL of the refrigerant and shall be calibrated to the refrigerant employed, and the appropriate percentage of gas (25% maximum) is confirmed.
 - Leak detection fluids are also suitable for use with most refrigerants but the use of detergents containing chlorine shall be avoided as the chlorine can react with the refrigerant and corrode the copper pipe-work.
Note: Examples of leak detection fluids are:
 - bubble method
 - fluorescent method agents
- If any hot work is to be conducted on the refrigerating equipment or any associated parts, appropriate fire extinguishing equipment shall be available on hand. A dry chemical or CO₂ fire extinguisher should be adjacent to the charging area. You must have a Class B chemical fire extinguisher available at all times.
- No person carrying out work in relation to a refrigerating system which involves exposing any pipe work shall use any sources of ignition in such a manner that it may lead to the risk of fire or explosion. All possible ignition sources, including cigarette smoking, should be kept sufficiently far away from the site of installation, repairing, removing, and disposal, during which refrigerant can possibly be released to the surrounding space. Prior to work taking place, the area around the equipment shall be surveyed to make sure that there are no flammable hazards or ignition risks. "No Smoking" signs shall be displayed.
- Ensure that the area is in the open or that it is adequately ventilated before breaking into the system or conducting any hot work. A degree of ventilation shall continue during the period that the work is carried out. The ventilation should safely disperse any released refrigerant and preferably expel it externally into the atmosphere.
- When breaking into the refrigerant circuit to make repairs – or for any other purpose – conventional procedures shall be used. However, for flammable refrigerants it is important that best practice be followed, since flammability is a consideration. The following procedure shall be adhered to:
 - safely remove refrigerant following local and national regulations
 - purge the circuit with inert gas
 - evacuate (optional for A2L)
 - purge with inert gas (optional for A2L)
 - open the circuit by cutting
- If a leak is suspected, all naked flames shall be removed/extinguished.
- If a leakage of refrigerant is found which requires brazing, all of the refrigerant shall be recovered from the system, or isolated (by means of shut off valves) in a part of the system remote from the leak.

⚠ DANGER continued

- When removing refrigerant from a system, either for servicing or decommissioning, it is recommended good practice that all refrigerants are removed safely.
- When transferring refrigerant into cylinders, ensure that only appropriate refrigerant recovery cylinders are employed. Ensure that the correct number of cylinders for holding the total system charge is available. All cylinders to be used are designated for the recovered refrigerant and labeled for that refrigerant (i.e., special cylinders for the recovery of refrigerant). Cylinders shall be complete with pressure-relief valve and associated shut-off valves in good working order. Empty recovery cylinders are evacuated and, if possible, cooled before recovery occurs.
- The recovery equipment shall be in good working order with a set of instructions concerning the equipment that is at hand and shall be suitable for the recovery of all appropriate refrigerants including, when applicable, flammable refrigerants. In addition, a set of calibrated weighing scales shall be available and in good working order. Hoses shall be complete with leak-free disconnect couplings and in good condition. Before using the recovery machine, check that it is in satisfactory working order, has been properly maintained and that any associated electrical components are sealed to prevent ignition in the event of a refrigerant release. Consult manufacturer if in doubt.
- The recovered refrigerant shall be returned to the refrigerant supplier in the correct recovery cylinder, and the relevant waste transfer note arranged. Do not mix refrigerants in recovery units and especially not in cylinders.
- If compressors or compressor oils are to be removed, ensure that they have been evacuated to an acceptable level to make certain that flammable refrigerant does not remain within the lubricant. The evacuation process shall be carried out prior to returning the compressor to the suppliers. Only electric heating to the compressor body shall be employed to accelerate this process. When oil is drained from a system, it shall be carried out safely.
- In addition to conventional charging procedures, the following requirements shall be followed:
 - Ensure that contamination of different refrigerants does not occur when using charging equipment. Hoses or lines shall be as short as possible to minimize the amount of refrigerant contained in them.
 - Cylinders shall be kept in an appropriate position according to the instructions.
 - Ensure that the refrigerating system is earthed (grounded) prior to charging the system with refrigerant.
 - Label the system when charging is complete (if not already).
 - Extreme care shall be taken not to overfill the refrigerating system.
- Prior to recharging the system, it shall be pressure-tested with the appropriate purging gas. The system shall be leak-tested on completion of charging but prior to commissioning. A follow up leak test shall be carried out prior to leaving the site.

DANGER continued

- Repair and maintenance to electrical components shall include initial safety checks and component inspection procedures. If a fault exists that could compromise safety, then no electrical supply shall be connected to the circuit until it is satisfactorily dealt with. If the fault cannot be corrected immediately but it is necessary to continue operation, an adequate temporary solution shall be used. This shall be reported to the owner of the equipment, so all parties are advised.
- Confirm that capacitors are discharged: this shall be done in a safe manner to avoid possibility of sparking.
- Confirm that no live electrical components and wiring are exposed while charging, recovering, or purging the system.
- Confirm that there is continuity of earth bonding (grounding).
- During repairs to sealed components, all electrical supplies shall be disconnected from the equipment being worked upon prior to any removal of sealed covers, etc. If it is absolutely necessary to have an electrical supply to equipment during servicing, then a permanently operating form of leak detection shall be located at the most critical point to warn of a potentially hazardous situation.
- Where electrical components are being changed, they shall be fit for the purpose and to the correct specification. At all times, Hoshizaki America's maintenance and service guidelines shall be followed. If in doubt, consult Hoshizaki America's Technical Support department for assistance.
- Confirm the actual refrigerant charge is in accordance with the room size within which the refrigerant containing parts are installed.
- Confirm the ventilation machinery and outlets are operating adequately and are not obstructed.
- Confirm marking to the equipment continues to be visible and legible. Markings and signs that are illegible shall be corrected.
- Confirm refrigerating pipe or components are installed in a position where they are unlikely to be exposed to any substance which may corrode refrigerant containing components, unless the components are constructed of materials which are inherently resistant to being corroded or are suitably protected against being so corroded.
- Particular attention shall be paid to the following to ensure that by working on electrical components, the casing is not altered in such a way that the level of protection is affected. This shall include damage to cables, excessive number of connections, terminals not made to original specification, damage to seals, incorrect fitting of glands, etc.
- Ensure that the apparatus (control box/component) is mounted securely.
- Ensure that seals or sealing materials have not degraded to the point that they no longer serve the purpose of preventing the ingress of flammable atmospheres. Replacement parts shall be in accordance with Hoshizaki America's specifications.
- Do not apply any permanent inductive or capacitance loads to the circuit without ensuring that this will not exceed the permissible voltage and current permitted for the equipment in use.

⚠ DANGER continued

- Intrinsically safe components are the only types that can be worked on while live in the presence of a flammable atmosphere. The test apparatus shall be at the correct rating.
- Replace components only with parts specified by Hoshizaki America. Other parts can result in the ignition of refrigerant in the atmosphere from a leak.
- Check that cabling will not be subject to wear, corrosion, excessive pressure, vibration, sharp edges, or any other adverse environmental effects. The check shall also take into account the effects of aging or continual vibration from sources such as compressors or fans.

2. Français



R-290 Classe A3 Réfrigérant Inflammable Utilisé

⚠ DANGER

Risque De Feu Ou D'Explosion. Fluide Frigorigène Inflammable Utilisé.

- Assurez-vous de suivre toutes les informations importantes de sécurité situées au début de ce manuel et dans cette section.
- L'appareil ne doit être diagnostiqué et réparé que par un personnel qualifié afin de prévenir les risques de mort, d'électrocution, de blessures graves ou d'incendie.
- L'entretien doit être effectué par du personnel formé et certifié pour la manipulation de réfrigérants inflammables afin de réduire au minimum le risque d'inflammation dû à des pièces incorrectes ou à un entretien inadéquat.
- Suivez attentivement les instructions de manutention conformément aux règlements nationaux.
- Ne pas utiliser de dispositifs mécaniques ou d'autres moyens pour accélérer le processus de dégivrage ou pour nettoyer, autres que ceux recommandés par le fabricant.
- Attention, les fluides frigorigènes peuvent ne pas dégager d'odeur.
- Ne pas perforer la tubulure contenant le frigorigène. Risque de feu ou d'explosion si la tubulure contenant le frigorigène est perforée; suivre les instructions de manutention avec soin.
- Les pièces doivent être remplacées par des pièces similaires, de manière à réduire au minimum le risque d'inflammation dû à des pièces incorrectes.
- Ne placez aucune source d'inflammation potentielle dans ou près de l'appareil.
- Avant de commencer à travailler sur des systèmes contenant des réfrigérants inflammables, des contrôles de sécurité sont nécessaires pour s'assurer que le risque d'inflammation est minimisé.
- Tout le personnel d'entretien et les autres personnes travaillant dans la zone locale doivent être informés de la nature des travaux effectués. Les travaux dans des espaces confinés doivent être évités.
- Les travaux doivent être entrepris selon une procédure contrôlée afin de minimiser le risque de présence de gaz ou de vapeur inflammable pendant l'exécution des travaux.
- La zone doit être contrôlée à l'aide d'un détecteur de réfrigérant approprié avant et pendant les travaux, afin de s'assurer que le technicien est conscient de l'existence d'atmosphères potentiellement toxiques ou inflammables.
- Assurez-vous que l'équipement de détection des fuites utilisé est adapté à l'utilisation de tous les réfrigérants applicables, c'est-à-dire qu'il ne produit pas d'étincelles, qu'il est correctement scellé ou qu'il est intrinsèquement sûr. REMARQUE: L'utilisation de mastic silicone peut réduire l'efficacité de certains types d'équipements de détection des fuites.

⚠ DANGER Continué

- En aucun cas, des sources potentielles d'inflammation ne doivent être utilisées pour rechercher ou détecter des fuites de réfrigérant. Une lampe haloïde (ou tout autre détecteur utilisant une flamme nue) ne doit pas être utilisée.
- Les méthodes de détection de fuite suivantes sont considérées comme acceptables pour tous les systèmes de réfrigération:
 - Des détecteurs de fuites électroniques peuvent être utilisés pour détecter les fuites de réfrigérants, mais, dans le cas de réfrigérants inflammables, la sensibilité pourrait ne pas être adéquate ou nécessiter un réétalonnage. (L'équipement de détection doit être étalonné dans une zone sans réfrigérant.) Assurez-vous que le détecteur n'est pas une source potentielle d'inflammation et qu'il est adapté au réfrigérant utilisé. L'équipement de détection des fuites doit être réglé sur un pourcentage de la LII du réfrigérant et doit être étalonné en fonction du réfrigérant utilisé, et le pourcentage approprié de gaz (25% au maximum) est confirmé.
 - Les liquides de détection des fuites conviennent également à la plupart des réfrigérants, mais l'utilisation de détergents contenant du chlore doit être évitée, car le chlore peut réagir avec le réfrigérant et corroder la tuyauterie en cuivre.
Remarque : Voici quelques exemples de liquides de détection de fuites :
 - méthode des bulles
 - agents de méthode fluorescents
- Si un travail à chaud doit être effectué sur l'équipement réfrigérant ou toute partie associée, un équipement d'extinction d'incendie approprié doit être disponible. Un extincteur à poudre chimique ou à CO₂ devrait être installé à proximité de la zone de chargement. Un extincteur chimique de classe B doit être disponible à tout moment.
- Il est interdit à toute personne effectuant des travaux en rapport avec un système réfrigérant qui impliquent la mise à nu d'une tuyauterie d'utiliser des sources d'inflammation de manière à entraîner un risque d'incendie ou d'explosion. Toutes les sources d'inflammation possibles, y compris la cigarette, doivent être suffisamment éloignées du site d'installation, de réparation, d'enlèvement et d'élimination, au cours desquels du réfrigérant peut éventuellement être libéré dans l'espace environnant. Avant d'entamer les travaux, la zone autour de l'équipement doit être étudiée pour s'assurer qu'il n'y a aucun risque d'inflammabilité ou d'inflammation. Des panneaux «Interdiction de fumer» doivent être affichés.
- Assurez-vous que la zone est à l'air libre ou qu'elle est correctement ventilée avant de pénétrer dans le système ou d'effectuer un travail à chaud. Un certain degré de ventilation doit être maintenu pendant la période où les travaux sont effectués. La ventilation doit permettre de disperser en toute sécurité tout réfrigérant libéré et, de préférence, de l'expulser dans l'atmosphère.

⚠ DANGER Continué

- Pour pénétrer dans le circuit du réfrigérant afin d'effectuer des réparations ou pour toute autre raison, des procédures conventionnelles doivent être utilisées. Toutefois, pour les réfrigérants inflammables, il est important de suivre les meilleures pratiques, car l'inflammabilité est un facteur à prendre en considération. La procédure suivante doit être respectée:
 - éliminer le réfrigérant en toute sécurité conformément aux réglementations locales et nationales
 - purger le circuit avec du gaz inerte
 - évacuer (en option pour A2L)
 - purger avec du gaz inerte (en option pour A2L)
 - ouvrir le circuit par coupure
- Si une fuite est suspectée, toutes les flammes nues doivent être enlevées/éteintes.
- Si une fuite de réfrigérant nécessitant un brasage est constatée, tout le réfrigérant doit être récupéré dans le système ou isolé (au moyen de vannes d'arrêt) dans une partie du système éloignée de la fuite.
- Lors de l'élimination du réfrigérant d'un système, que ce soit pour l'entretien ou la mise hors service, il est recommandé de veiller à ce que tous les réfrigérants soient éliminés en toute sécurité.
- Lors du transfert de réfrigérant dans des bouteilles, veillez à ce que seules des bouteilles de récupération de réfrigérant appropriées soient utilisées. Assurez-vous que le nombre de bouteilles nécessaires pour contenir la charge totale du système est disponible. Toutes les bouteilles à utiliser sont désignées pour le réfrigérant récupéré et étiquetées pour ce réfrigérant (c'est-à-dire des bouteilles spéciales pour la récupération du réfrigérant). Les bouteilles doivent être équipées d'une soupape de surpression et de soupapes d'arrêt associées qui sont en bon état de fonctionnement. Les bouteilles de récupération vides sont évacuées et, si possible, refroidies avant la récupération.
- L'équipement de récupération doit être en bon état de fonctionnement, accompagné d'un ensemble d'instructions concernant l'équipement disponible et doit être adapté à la récupération de tous les réfrigérants appropriés, y compris, le cas échéant, les réfrigérants inflammables. En outre, un ensemble de balances étalonnées doit être disponible et en bon état de fonctionnement. Les tuyaux doivent être complets, équipés de raccords de déconnexion sans fuite et en bon état. Avant d'utiliser la machine de récupération, vérifiez qu'elle est en bon état de fonctionnement, qu'elle a été correctement entretenue et que tous les composants électriques associés sont scellés pour éviter toute inflammation en cas de fuite de réfrigérant. Consulter le fabricant en cas de doute.
- Le réfrigérant récupéré doit être renvoyé au fournisseur de réfrigérant dans la bouteille de récupération appropriée et le bon de transfert de déchets correspondant doit être établi. Ne mélangez pas les réfrigérants dans les unités de récupération et surtout pas dans les bouteilles.

⚠ DANGER Continué

- Si les compresseurs ou les huiles de compresseur doivent être retirés, assurez-vous qu'ils ont été évacués à un niveau acceptable afin de s'assurer qu'il ne reste pas de réfrigérant inflammable dans le lubrifiant. Le processus d'évacuation doit être effectué avant que le compresseur ne soit renvoyé aux fournisseurs. Seul le chauffage électrique du boîtier du compresseur doit être utilisé pour accélérer ce processus. Lorsque l'huile est vidangée d'un système, cette opération doit être effectuée en toute sécurité.
- En plus des procédures de charge conventionnelles, les exigences suivantes doivent être respectées :
 - S'assurer qu'aucune contamination de différents réfrigérants ne se produit lors de l'utilisation de l'équipement de charge. Les tuyaux ou conduites doivent être aussi courts que possible afin de minimiser la quantité de réfrigérant qu'ils contiennent.
 - Les bouteilles doivent être maintenues dans une position appropriée conformément aux instructions.
 - S'assurer que le système de réfrigération soit mis à la terre avant de charger le système avec du réfrigérant.
 - Étiqueter le système lorsque la charge est terminée (si cela n'a pas déjà été fait).
 - Il faut veiller à ne pas trop remplir le système de réfrigération.
- Avant de recharger le système, celui-ci doit être testé sous pression avec le gaz de purge approprié. Le système doit être soumis à un essai de fuite à la fin de la charge, mais avant la mise en service. Un test de contrôle de fuite doit être effectué avant de quitter le site.
- La réparation et l'entretien des composants électriques incluent les contrôles de sécurité initiaux et les procédures d'inspection des composants. En cas de défaut susceptible de compromettre la sécurité, aucune alimentation électrique ne doit être connectée au circuit tant que le problème n'a pas été résolu de manière satisfaisante. Si le défaut ne peut être corrigé immédiatement mais qu'il est nécessaire de poursuivre l'exploitation, une solution temporaire adéquate doit être utilisée. Cela doit être signalé au propriétaire de l'équipement, afin que toutes les parties soient informées.
- S'assurer que les condensateurs sont déchargés : cette opération doit être effectuée en toute sécurité afin d'éviter tout risque d'étincelle.
- S'assurer qu'aucun composant ou câblage électrique sous tension n'est exposé lors de la charge, de la récupération ou de la purge du système.
- S'assurer de la continuité de la mise à la terre.
- Lors des réparations de composants scellés, toutes les alimentations électriques doivent être déconnectées de l'équipement sur lequel on travaille avant tout retrait des couvercles scellés, etc. Si l'alimentation électrique de l'équipement est absolument nécessaire pendant l'entretien, un dispositif de détection des fuites fonctionnant en permanence doit être placé au point le plus critique afin de signaler en cas de situation potentiellement dangereuse.
- Lorsque des composants électriques sont remplacés, ils doivent être adaptés à l'usage prévu et répondre aux spécifications correctes. Les directives de maintenance et d'entretien de Hoshizaki America doivent être respectées à tout moment. En cas de doute, consulter le service d'assistance technique de Hoshizaki America pour obtenir de l'aide.

⚠ DANGER Continué

- S'assurer que la charge réelle de réfrigérant est conforme à la taille de la pièce dans laquelle les pièces contenant du réfrigérant sont installées.
- S'assurer que les dispositifs et les sorties de ventilation fonctionnent correctement et ne sont pas obstrués.
- S'assurer que le marquage de l'équipement est toujours visible et lisible. Les indications et les panneaux illisibles doivent être corrigés.
- S'assurer que les tuyaux ou les composants de réfrigération sont installés dans un endroit où ils ne risquent pas d'être exposés à une substance susceptible de corroder les composants contenant du réfrigérant, à moins que les composants ne soient construits avec des matériaux intrinsèquement résistants à la corrosion ou qu'ils ne soient protégés de manière appropriée contre la corrosion.
- Une attention particulière doit être accordée aux points suivants afin de s'assurer qu'en travaillant sur les composants électriques, le boîtier n'est pas altéré de manière à ce que le niveau de protection soit affecté. Il s'agit notamment des dommages causés aux câbles, du nombre excessif de connexions, des terminaux non conformes aux spécifications d'origine, des dommages causés aux joints et du montage incorrect des presse-étoupes, etc.
- S'assurer que l'appareil (boîtier de commande/composant) est solidement fixé.
- S'assurer que les joints ou les matériaux d'étanchéité ne sont pas dégradés au point de ne plus pouvoir empêcher la pénétration d'atmosphères inflammables. Les pièces de rechange doivent être conformes aux spécifications de Hoshizaki America.
- N'appliquez aucune charge inductive ou capacitive permanente au circuit sans vous assurer que celle-ci ne dépassera pas la tension et le courant autorisés pour l'équipement utilisé.
- Les composants à sécurité intrinsèque sont les seuls types de composants sur lesquels il est possible de travailler sous tension en présence d'une atmosphère inflammable. L'appareil d'essai doit être adapté à la puissance requise.
- Ne remplacer les composants que par des pièces spécifiées par Hoshizaki America. D'autres pièces peuvent entraîner l'inflammation du réfrigérant dans l'atmosphère à la suite d'une fuite.
- Vérifier que le câblage ne sera pas soumis à l'usure, à la corrosion, à une pression excessive, à des vibrations, à des arêtes vives ou à tout autre effet environnemental négatif. Le contrôle doit également prendre en compte les effets du vieillissement ou des vibrations continues provenant de sources telles que les compresseurs ou les ventilateurs.

B. Service Diagnosis



R-290 Class A3 Flammable Refrigerant Used

⚠ DANGER

Risk of Fire or Explosion. Flammable Refrigerant Used.

- Be sure to follow all Important Safety Information located at the beginning of this manual and at the beginning of section "III.A. Safety Precautions When Servicing."
- Servicing shall be done by trained service personnel with certified competence in handling flammable refrigerants to minimize the risk of possible ignition due to incorrect parts or improper service.

Risque De Feu Ou D'Explosion. Fluide Frigorigène Inflammable Utilisé.

- Assurez-vous de suivre toutes les informations importantes de sécurité qui se trouvent au début du présent manuel et au début de la section «III.A. Précautions de sécurité lors de l'entretien.»
- L'entretien doit être effectué par du personnel formé et certifié pour la manipulation de réfrigérants inflammables afin de réduire au minimum le risque d'inflammation dû à des pièces incorrectes ou à un entretien inadéquat.

⚠ WARNING

- Risk of electric shock. Use extreme caution and exercise safe electrical practices.
- Unplug the appliance before servicing.
- Moving parts (e.g., fan blade) can crush and cut. Keep hands clear.
- Make sure all food zones in the appliance are clean after service.

1. Diagnostic Procedures

The diagnostic procedure is a sequence check that allows you to diagnose the electrical system and components. Before proceeding, check for correct installation and proper voltage per nameplate.





See the table for default cabinet temperature control dial settings.

Model	Default Cabinet Temperature Control Dial Setting	Approximate Default Temperature
UR/WR - Undercounter/Worktop	5	Refrigerator: 34°F (1°C)
SR - Prep Table	5	Refrigerator: 34°F (1°C)
UF/WF - Undercounter/Worktop	7	Freezer: -5°F (-21°C)

Confirm that the appliance location meets factory requirements:

- This appliance is not intended for outdoor use. Normal operating ambient temperature:
 - All UR/WR and Solid Door UF/WF 45°F to 100°F (7°C to 38°C)
 - SR 45°F to 86°F (7°C to 30°C)
 - UF Glass Door 45°F to 80°F (7°C to 27°C).
- The appliance should not be located next to ovens, grills, or other high heat producing equipment. Check CM using the steps in "II.C. Control Module Check."

- Note:
- When checking voltage (115VAC), always choose a neutral white (W) wire to establish a good neutral connection.
 - Control module has high and low voltage protection. If off on either protection, no LED is visible and all components are off.
High Voltage: 140VAC
Low Voltage: 90VAC
 - There is a 2 min. minimum compressor on time for all models and a 2-min. minimum compressor off time for UR/WR and SR and a 3-min. minimum compressor off time for UF/WF.
 - The control module incorporates LEDs to identify sequence of operation. Reference the table below to assist in the diagnostic process.

CONTROL MODULE LED OPERATION			
LEDs			LED OPERATION
G	R	B	
OFF	ON	OFF	STANDBY MODE
	OFF	OFF	NORMAL MODE
	OFF	ON	COOLING CYCLE
	OFF		DEFROST CYCLE
LED OPERATION LEGEND			
		FLASHING	

- 1) Unplug the appliance from the electrical outlet.
- 2) Remove the CM mounting bracket and place the CM in a place where the LEDs are visible.
- 3) Plug the appliance back into the electrical outlet. If appliance was in defrost when power supply was disconnected, defrost is terminated and normal cooling cycle begins.
- 4) **Startup/Cool Down**—All 3 LEDs flash on, then off, then the green LED flashes, and solid blue LED turns on (normal cooling cycle). CTh Temperature above setpoint, Comp, ConFM, EvapFM, PH (UF/WF only), and MH (UF/WF only) energize. 2-min. Comp on timer and 5-hr. DT starts.
 - a) **CTh Diagnosis:** If CTh fails, green and red LEDs flash on the CM. Confirm CTh is properly connected to CM. Check Ohm reading of CTh. See "II.D. Thermistor Check." Replace as needed.
 - b) **CM Diagnosis:** Confirm green LED is flashing. If not, confirm dial is set above zero. Next, check for 115VAC between CM Live In black (BK) wire and a neutral white (W) wire. If 115VAC is not present, check power cord connections and breaker/fuse. Confirm wiring connections are secure for both CM Live In black (BK) and a neutral white (W) wire. If 115VAC is present, dial is set above zero, and CM green LED is not on, replace CM.
 - c) **Comp/ConFM Diagnosis:** Check that Comp and ConFM energize. Next, check for 115VAC at CM Comp violet (V) wire to a neutral white (W) wire. If 115VAC is not present at CM Comp violet (V) to a neutral white (W) wire, check CTh status. See "II.D. Thermistor Check." If CTh ohm reading is in proper range, replace CM. Comp: If 115VAC is present, check Comp external overload, start or run cap (if applicable), PTC relay or start relay, and Comp motor windings. Replace as needed. ConFM: If 115VAC is present, check fan blade for binding, then check ConFM motor windings. If Comp, ConFM, and EvapFM are energized and the cabinet does not cool down, check for a restriction in the refrigeration circuit, low refrigerant charge, or inefficient Comp.
 - d) **EvapFM Diagnosis:** Check that EvapFM(s) energize. If not, check for 115VAC at CM Aux 1 black-smooth (BK-SM) wire to neutral white (W) wire. If 115VAC is not present, replace CM. If 115VAC is present, check fan blades for binding, then check EvapFM motor windings.
 - e) **PH and MH Diagnosis (UF/WF only):** PH and MH follow Comp operation. When Comp is energized, PH and MH are energized. If 115VAC is present, check amp draw of PH and MH. If an amp reading is not present, check the continuity of PH and MH. If defective, replace PH or MH.
 - f) **Glass Door Cabinet LEDs Diagnosis:** LED(s) are activated by CLS. If CLS is engaged and LED(s) fail to turn on, check for 115VAC at both CLS (Y) wires to a neutral white (W) wire. If 115VAC is present on one end and not the other, check CLS continuity. If open replace CLS. If CLS is closed and 115VAC is present on both CLS (Y) wires to a neutral (W), check for 24VDC at DCD black (BK) wire to DCD red (R) wire. If 24VDC is not present, check continuity of DCD driver. If open, replace DCD driver. If 24VDC is present and LED(s) are not on, check wiring harness and wiring connections from DCD to LED(s). If connections are good and LED(s) are not on, replace CM.

5) **Cool Down Achieved**—CTh reaches setpoint temperature.

All Models: Comp and ConFM de-energize.

UR/WR and UF/WF: EvapFM de-energize.

SR: EvapFM continues.

Diagnosis: If temperature setpoint achieved and Comp, ConFM, and EvapFM does not de-energize (except SR), check CTh continuity. See "II.D. Thermistor Check."

If CTh is defective, replace. If CTh is good and either the Comp, ConFM, or EvapFM continue, replace CM. SR: If EvapFM de-energizes, check for 115VAC at CM Aux 1 black-smooth (BK-SM) wire to neutral white (W) wire. If 115VAC is not present, replace CM. If 115VAC is present, check fan blades for binding, then check EvapFM motor windings.

6) **Defrost**—Manual, temperature, and time-initiated defrost with temperature-terminated defrost. Defrost has a 1-hr. maximum time.

1a) **Manual-Initiation (All):** Rotate the CTCD clockwise to position 9 (blue LED on, green LED flashes, red LED off), move counter-clockwise to position 1 (blue LED remains on, green LED continues to flash), move back clockwise again to position 9 (blue and green LEDs flash). Defrost initiates.

Note: Once at the number position, confirm the appropriate LEDs are on or flashing. After initiation, move the dial back to factory default setting.

1b) **Temperature Initiation:**

(1) **UR/WR:** DTh is at or below -4°F (-20°C), defrost starts. CM blue and green LEDs flashing. If energized, Comp and ConFM de-energize. EvapFM continues.

(2) **SR:** DTh is at or below -31°F (-35°C), defrost starts. CM blue and green LEDs flashing. If energized, Comp, ConFM, and EvapFM de-energize. DH energizes. 1-hr. maximum DT starts.

(3) **UF/WF:** DTh at or below -31°F (-35°C), defrost starts. CM blue and green LEDs flashing. If energized, Comp, ConFM, EvapFM, PH, and MH de-energize. DH energizes. 1-hr. maximum DT starts.

1c) **Time Initiation (All):**

4-hr. cumulative compressor run timer terminates, defrost starts.

(1) **UR/WR:** Comp and ConFM de-energize. EvapFM continues. 1-hr. maximum DT starts.

(2) **SR:** Comp, ConFM, and EvapFM de-energize. DH energizes. 1-hr. maximum DT starts.

(3) **UF/WF:** Comp, ConFM, EvapFM, PH, and MH de-energize. DH energizes. 1-hr. maximum DT starts.

2a) **Manually-Terminated:** Set the CTCD to the off position, then back to original setting or unplugging and plugging back in to the electrical outlet. Defrost terminated.

2b) Temperature or Time Terminated:

- (1) **UR/WR:** 45°F (7.2°C) achieved or 1-hr. backup DT terminates. If CTh calling for cooling, Comp and ConFM energize. EvapFM continues.
- (2) **SR:** 46°F (7.7°C) achieved or 1-hr. backup DT terminates. DH de-energizes. Comp, ConFM, and EvapFM energize.
- (3) **UF/WF:** 55°F (12.7°C) achieved or 1-hr. backup DT terminates. DH de-energizes. 3-min. DOT starts. 3-min. DOT terminates. If CTh calling for cooling, Comp, ConFM, PH, and MH energize. 3-min. EvapFM delay timer terminates, EvapFM energizes.

Defrost Diagnosis

- 1) **Manual Initiated:** Rotate the CTCD clockwise to position 9 (blue LED turns on, green LED flashing), move counter-clockwise to position 1 (blue LED turns on, green LED flashing), move back clockwise again to position 9 (blue and green LEDs flashing). Defrost initiates. Note: Once at the number position, confirm the appropriate LEDs are on or flashing. If not, move the CTCD back and forth until the LED turns on. Once the LED is on, move to the next position. After several attempts and the LEDs do not turn on and off as listed above, replace the CM. If defrost does not initiate after all the LEDs properly turn on and off, replace the CM. Once initiated, see component diagnosis below in "3) Time Initiated."

2) Temperature Initiated:

- a) **UR/WR:** Has DTh cooled to -4°F (-20°C) or lower?
- b) **SR:** Has DTh cooled to -31°F (-35°C) or lower?
- a) **UF/WF:** Has 1-hr. DLT terminated? Has DTh cooled to -31°F (-35°C) or lower?
 - (1) **DTh Diagnosis:** If DTh has cooled to proper temperature, confirm DTh status. See "II.D. Thermistor Check."
 - (2) **CM Diagnosis:** Check that CM blue and green LEDs are flashing. If not, and DTh ohm reading is in proper range, replace CM.

3) Time Initiated: 5-hr. cumulative compressor run timer terminates.

- (1) **CM Diagnosis:** Confirm blue and green LEDs are flashing. If not, After attempting CTCD sequence several times and defrost still not initiated, wait 1 to 2 min. and repeat process. If defrost cycle still not activated, replace CM as needed.
- (2) **Comp and ConFM Diagnosis:** Confirm Comp and ConFM de-energize. If not, check for 115VAC at CM Comp violet (V) wire to a neutral white (W) wire. If 115VAC is present, Check DTh continuity. See "II.D. Thermistor Check." Replace as needed. If DTh confirmed, replace CM.

(3) **EvapFM Diagnosis**

UR/WR: EvapFM continues. If not, check for 115VAC at CM AUX 1 black-smooth (BK-SM) wire to a neutral white (W). If 115VAC is not present, replace CM.

SR and UF/WF: Confirm EvapFM de-energizes. If not, check for 115VAC at CM AUX 1 black-smooth (BK-SM) to a neutral white (W). If 115VAC is present, confirm Comp and ConFM de-energized. Next, check DTh continuity. See "II.D. Thermistor Check." Replace as needed. If DTh confirmed, replace CM.

- (4) **DH Diagnosis (SR and UF/WF):** Confirm DH energizes. Check for 115VAC at CM AUX 2 black (BK) wire to a neutral white (W). If 115VAC is present, confirm Comp, ConFM, and EvapFM de-energized. Next, check DTh continuity. See "II.D. Thermistor Check." Replace as needed. If DTh confirmed, replace CM.

2) **Defrost Termination**

Manually Terminated Defrost: Set the CTCD to the off position, then back to original setting or unplugging and plugging back in to the electrical outlet. Defrost terminated. If not, replace CM.

Temperature/Time Terminated Defrost

- a) **UR/WR:** DTh warms to 45°F (7.2°C). Confirm continuity of DTh. See "II.D. Thermistor Check." Replace as needed. If DTh confirmed, replace CM. Once defrost termination achieved, EvapFM continues. Comp and ConFM energize. If not, see "4) Startup/Cool down" above.
- b) **SR:** DTh warms to 46°F (7.7°C). DH de-energizes. Confirm continuity of DTh. See "II.D. Thermistor Check." Replace as needed. If DTh is good and DH continues after DTh achieves 46°F (7.7°C), replace CM. Comp, ConFM, and EvapFM energize. If not, see "4) Startup/Cool down" above.
- c) **UF/WF:** DTh warms to 55°F (12.7°C) DH de-energizes. Confirm continuity of DTh. See "II.D. Thermistor Check." Replace as needed. If DTh is good and DH continues after DTh achieves 55°F (12.7°C), replace CM. 3-min. DOT starts. 3-min. DOT terminates. If CTh calling for cooling, Comp, ConFM, PH, and MH energize. 3-min. EvapFM delay timer terminates, EvapFM energizes. If not, see "4) Startup/Cool down" above.

Legend: **Comp**—compressor; **ConFM**—condenser fan motor; **CLS**—cabinet light switch; **CM**—control module; **CTCD**—cabinet temperature control dial; **CTh**—cabinet thermistor; **DH**—defrost heater; **DLT**—defrost lock-out timer; **DST**—defrost safety thermostat; **DT**—defrost timer; **DTh**—defrost thermistor; **EvapFM**—evaporator fan motor; **HPS**—high-pressure switch; **MH**—mullion heater; **PH**—perimeter heater

C. Control Module Check

1. Control Module

Before replacing a CM that does not show a visible defect and that you suspect is bad, conduct the following check procedure. This procedure will help you verify your diagnosis. Always choose a neutral white (W) wire to establish a good power supply and neutral connection to CM. Check that 115VAC is present between CM Live In black (BK) wire and CM Neutral white (W) wire. Confirm defrost and cabinet thermistors are connected.

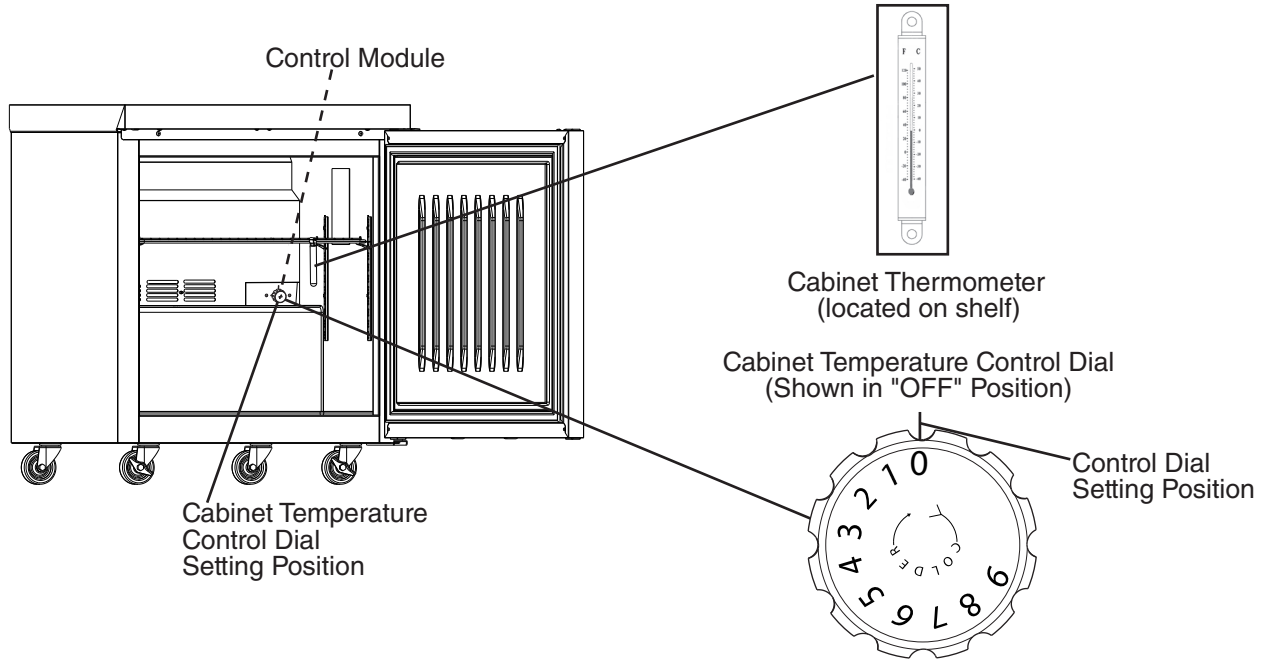

Rear

Control Module

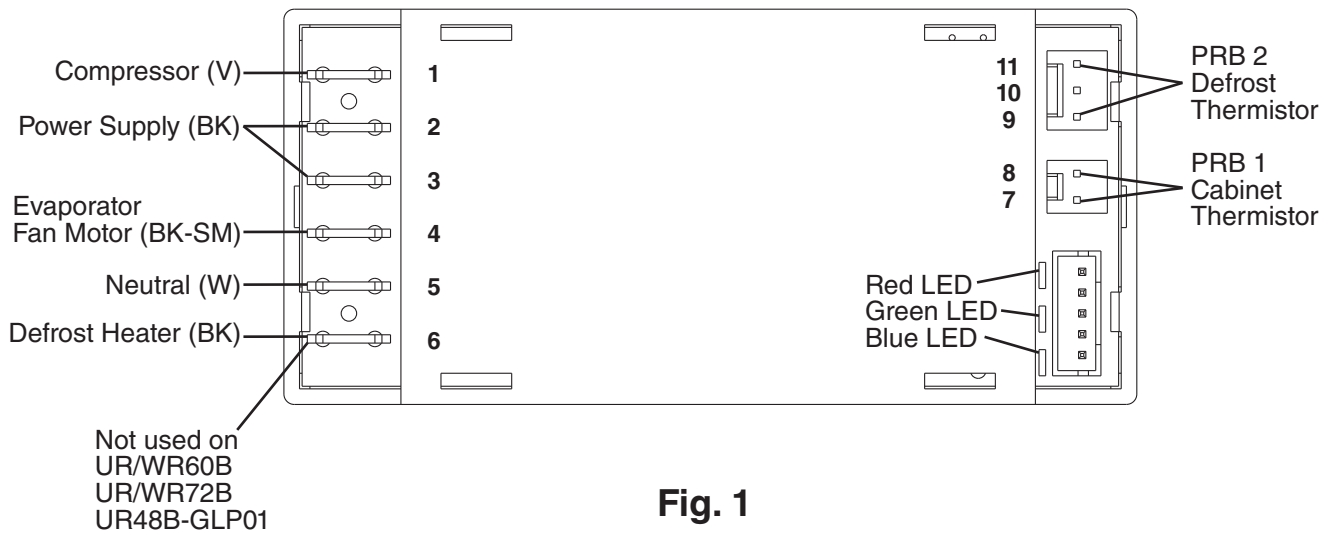







Fig. 1

1a. Control Module LED Operation:

The control module has 3 LEDs that illuminate based on the status of the thermistors. Blue (B), Green (G), and Red (R).

- a) Warm Cabinet Thermistor - Power on: All 3 LEDs turn on for 2 sec. then turn off. Next, red (R) LED turns on with dial set on 0 ("OFF").
- b) Warm Cabinet Thermistor - Dial set to above 0, Comp energizes: Blue (B) LED turns on, green (G) LED flashing (normal cooling cycle), red LED turns off.
- c) Cool Cabinet Thermistor - Cabinet temperature achieved. Compressor de-energizes: Blue (B) LED turns off, green (G) LED flashes (normal off cycle).
- d) Defrost initiated: Blue (B) and green (G) LEDs flashing.
- e) Defrost Thermistor Failure: Blue (B) LED on, red (R) and green (G) LEDs flashing.
- f) Control Dial placed in the "OFF" position: Red (R) LED on.

- g) Cabinet Thermistor Fault: Blue (B) LED on, red (R) and green (G) LEDs flashing.
Note: on cabinet thermistor fault appliance cycles 5-min. on 5-min. off until cabinet thermistor connection restored or cabinet thermistor replaced.

CONTROL MODULE LED OPERATION			
LEDs			LED OPERATION
G	R	B	
OFF	ON	OFF	STANDBY MODE
	OFF	OFF	NORMAL MODE
	OFF	ON	COOLING CYCLE
	OFF		DEFROST CYCLE
LED OPERATION LEGEND			
		FLASHING	

2. Startup/Cool Down

At startup, CM displays a flash of the solid blue, green, and red LEDs, then solid blue LED turns on (normal cooling cycle), red LED turns off, and green LED continues to flash. Unless 2-min. Comp delay timer is on. CTh Diagnosis: If green and red LEDs flashing (CTh fault code), check CTh for continuity and good connection to CM. See "II.D. Thermistor Check."

- 1) Check all wiring connections.
- 2) Be sure the power supply is connected to the electrical outlet.
- 3) Confirm the CTh is properly connected (green LED flashing). A Solid blue LED turns on at startup (CTh above setpoint). If the red LED starts flashing, check CTh continuity. Replace as needed.
- 4) Check that Comp, ConFM, EvapFM, PH (UF/WF) and MH (UF/WF) energize. If not check CTh status. See "II.D. Thermistor Check." If CTh ohm reading is in proper range, **Comp, ConFM, PH (UF/WF) and MH (UF/WF)**; check for 115VAC at COMP violet (V) to a neutral white (W) wire. If 115VAC is not present, replace CM. If 115VAC is present and Comp energized and ConFM did not, check ConFM blades for binding and motor winding continuity. If PH (UF/WF) or MH (UF/WF) do not energize, check continuity, replace MH as needed.
EvapFM; Check for 115VAC at AUX 1 black-smooth (BK-SM) to neutral white (W). If 115VAC is not present, replace CM. If 115VAC is present, check EvapFM blades for binding and motor winding continuity.

3. Defrost Initiation

- 5) **Manual Defrost Check:** Rotate the CTCD clockwise to position 9 (blue LED comes on, green LED flashing), move counter-clockwise to position 1 (blue LED comes on, green LED flashing), move back clockwise to position 9 (blue and green LEDs flashing). Defrost initiates. Note: After attempting CTCD sequence several times and defrost still not initiated, wait 1 to 2 min. and repeat process. If defrost cycle still not activated, replace CM as needed.
- 6) **UR/WR Defrost Check:** Confirm EvapFM remains energized.
- 7) **SR and UF/WF Defrost Check:** Confirm Comp, ConFM, EvapFM, PH (UF/WF), and MH (UF/WF) de-energizes. If not, for Comp and ConFM, check for 115VAC at COMP violet (V) wire to neutral white (W) wire and for EvapFM check for 115VAC at AUX 1 black/smooth (BK/SM) to neutral white (W) wire. If 115VAC is present, replace CM. Confirm DH energizes. If not, check for 115VAC at AUX 2 black (BK) wire to neutral white (W) wire. If 115VAC is not present, replace CM.

4. Defrost Termination

- 8) Check that all components restart after defrost termination.
 - a) **UR/WR:** DTh warms to 45°F (7.2°C). Confirm continuity of DTh.
See "II.D. Thermistor Check." Replace as needed. If DTh confirmed, replace CM.
 - b) **SR:** DTh warms to 46°F (7.7°C). DH de-energizes. Confirm continuity of DTh.
See "II.D. Thermistor Check." Replace as needed. If DTh is good and DH continues after DTh achieves 46°F (7.7°C), replace CM.
 - c) **UF/WF:** DTh warms to 55°F (12.7°C). DH de-energizes. Confirm continuity of DTh.
See "II.D. Thermistor Check." Replace as needed. If DTh is good and DH continues after DTh achieves 55°F (12.7°C), replace CM. 3-min. DOT starts. All components are de-energized during DOT. 3-min. DOT terminates, Comp and ConFM energize. If not, check for 115VAC at CM Neutral white (W) wire to CM Comp violet (V) wire. If 115VAC is not present, replace CM. Once Comp energizes, 3-min. EvapFM delay timer starts. EvapFM energizes when DT achieves 10°F (-12.2°C) or the EvapFM delay timer terminates. Whichever comes first. If EvapFM does not energize, check for 115VAC at CM Neutral white (W) wire to CM Aux 1 black-smooth (BK-SM) wire. If 115VAC is not present, replace CM.

Legend: **Comp**—compressor; **ConFM**—condenser fan motor; **CM**—control module;
CTCD—cabinet temperature control dial; **CTh**—cabinet thermistor;
DH—defrost heater; **DOT**—drip off time; **DTh**—defrost thermistor;
EvapFM—evaporator fan motors, **MH**—mullion heater; **PH**—perimeter heater

D. Thermistor Check

The cabinet thermistor works in conjunction with cabinet temperature control dial (CTCD) to control cabinet temperature. The defrost thermistor is used for defrost initiation and termination on all models and evaporator fan motor restart on UF/WF.

- **UR/WR:** Defrost termination is 45°F (7.2°C).
- **SR:** Defrost termination is 46°F (7.7°C).
- **UF/WF:** Defrost initiation is below -31°F (-35°C).
Defrost termination is 55°F (12.7°C).
- **UR/WR:** Evaporator fan motor is energized during defrost.
- **SR and UF/WF:** Evaporator fan motor de-energized during defrost.
UF/WF Only; Evaporator fan motor is delayed until 3-min. EvapFM delay timer terminates after defrost termination.

Thermistor resistance varies depending on temperature. The control module monitors the thermistors and cabinet temperature control dial (CTCD) to control system operation. No adjustment is required.

To check thermistor resistance, follow the steps below.

- 1) Unplug the appliance from the electrical outlet.
- 2) Remove the evaporator shroud and rear louver.
- 3) Disconnect the thermistor connector from the control module.
- 4) Check the resistance between the wires at the thermistor connector. Normal reading is 10 kΩ +/- 1% @77°F (25°C). If outside the normal reading, replace the thermistor.
- 5) Reconnect and replace the thermistor and thermistor connector in their correct positions. Note: After working with or around the defrost thermistor on an SR or UF/WF, make sure the defrost thermistor wire is not touching the defrost heater.
- 6) Replace the evaporator shroud and rear louver. Plug the appliance back in to the electrical outlet.

E. Diagnostic Table

Before consulting the diagnostic tables, check the following:

- Check the cabinet temperature control dial setting. See the table for default cabinet temperature control dial settings.

Model	Default Cabinet Temperature Control Dial Setting	Approximate Default Temperature
UR/WR - Undercounter and Worktop	5	Refrigerator: 34°F (1°C)
SR - Prep Table	5	Refrigerator: 34°F (1°C)
UF/WF - Undercounter and Worktop	7	Freezer: -5°F (-21°C)

- Make sure the doors are not left open or opened too often and that they are sealing properly.
- On SR models, pans and rail dividers must be in place. Otherwise, the rail will not cool properly.
- Make sure product is not blocking airflow and that the cabinet is not overloaded with warm or hot product. Product should be allowed to cool before putting in the appliance. On SR models, only load ingredients that have been pre-chilled to 37°F (3°C) or less.
- Check for correct installation and proper voltage per appliance nameplate.
This appliance is not intended for outdoor use. Normal operating ambient temperature:
 - All UR/WR and Solid Door UF/WF 45°F to 100°F (7°C to 38°C)
 - SR 45°F to 86°F (7°C to 30°C)
 - UF Glass Door 45°F to 80°F (7°C to 27°C)
- The appliance should not be located next to ovens, grills, or other high heat producing equipment. A minimum of 1.5" (38 mm) overhead clearance is required for proper ventilation.

1. Appliance Not Cooling

Appliance Not Cooling - Possible Cause	
1. Power Supply	a) Unplugged, blown fuse, or tripped or defective circuit breaker.
	b) Loose connection.
	c) Not within specifications.
2. Power Supply Cord and Plug	a) Loose connection.
	b) Defective.
3. Wiring	a) Loose connection or disconnected.
	b) Defective.
4. Cabinet Thermistor	a) Loose, disconnected, or defective.
5. Control Module See "II.C. Control Module Check" and "II.D. Thermistor Check"	a) Control module LEDs flashing - CTh fault code (blue (B) and green (G) LEDs flashing).
	b) Defective.
6. Evaporator Fan Motor	a) Fan blade binding.
	b) Defective.
7. Condenser Fan Motor	a) Fan blade binding.
	b) Defective.
8. Compressor External Protector	a) Dirty condenser.
	b) Condenser fan motor not operating.
	c) Start or PTC relay defective.
	d) Start or Run capacitor (if applicable) defective.
	e) Defective.
	f) Low charge.
9. Compressor	a) Defective.
10. Condenser	a) Dirty.
11. Evaporator	a) Dirty or frozen up.
12. Refrigerant/Refrigerant Lines	a) Low.
	b) Refrigerant lines or components restricted.

2. Evaporator is Frozen Up

Evaporator is Frozen Up - Possible Cause	
1. Evaporator	a) Dirty.
2. Evaporator Fan Motor	a) Fan blade binding.
	b) Defective.
3. Cabinet Thermistor See "II.D. Thermistor Check"	a) Defective.
4. Control Module See "II.C. Control Module Check"	a) Defective.
5. Defrost Thermistor See "II.D. Thermistor Check"	a) Defective.
6. Defrost Heater (if applicable)	a) Defective.
7. Defrost Safety Thermostat Open (if applicable)	a) Defective. Open. Cut-out: 120°F±5°F (49°C±3°C), Cut-in: 70°F±5°F (21°C±3°C).
8. Refrigerant Charge	a) Low.

3. Defrost

UR/WR Defrost - Possible Cause	
1. Control Module (fails to initiate) See "II.C. Control Module Check"	a) Defective-Cumulative 5-hr. defrost timer fails.
	b) Defective-1-hr. defrost lock-out timer fails.
2. Control Module (fails to terminate) See "II.C. Control Module Check"	a) Defrost thermistor connection loose.
	b) Defective.
3. Defrost Thermistor (Confirm DTh status. See "II.D. Thermistor Check")	a) Defective.
SR and UF/WF Defrost - Possible Cause	
1. Control Module (fails to initiate) See "II.C. Control Module Check"	a) Defective (Cumulative 5-hr. defrost timer fails).
2. Defrost Safety Thermostat	a) Defective. Open. Cut-out: 120°F±5°F (49°C±3°C), Cut-in: 70°F±5°F (21°C±3°C).
3. Defrost Heater	a) Defrost safety thermostat open.
	b) Defective.
4. Defrost Thermistor (Confirm DTh status. See "II.D. Thermistor Check")	a) Defective.
5. Control Module (fails to terminate) See "II.C. Control Module Check"	a) Defrost thermistor connection loose.

F. Controls and Adjustments

1. Temperature Reading

A thermometer with both °F and °C scales is mounted in the cabinet. See Fig. 1.

2. Cabinet Temperature

The appliance features a cabinet temperature control dial (CTCD). The warmest setting is 1 and the coldest setting is 9. See the table for default cabinet temperature control dial settings.

Model	Default Cabinet Temperature Control Dial Setting	Approximate Default Temperature
UR/WR - Undercounter/Worktop	5	Refrigerator: 34°F (1°C)
SR - Prep Table	5	Refrigerator: 34°F (1°C)
UF/WF - Undercounter/Worktop	7	Freezer: -5°F (-21°C)

Fig. 1

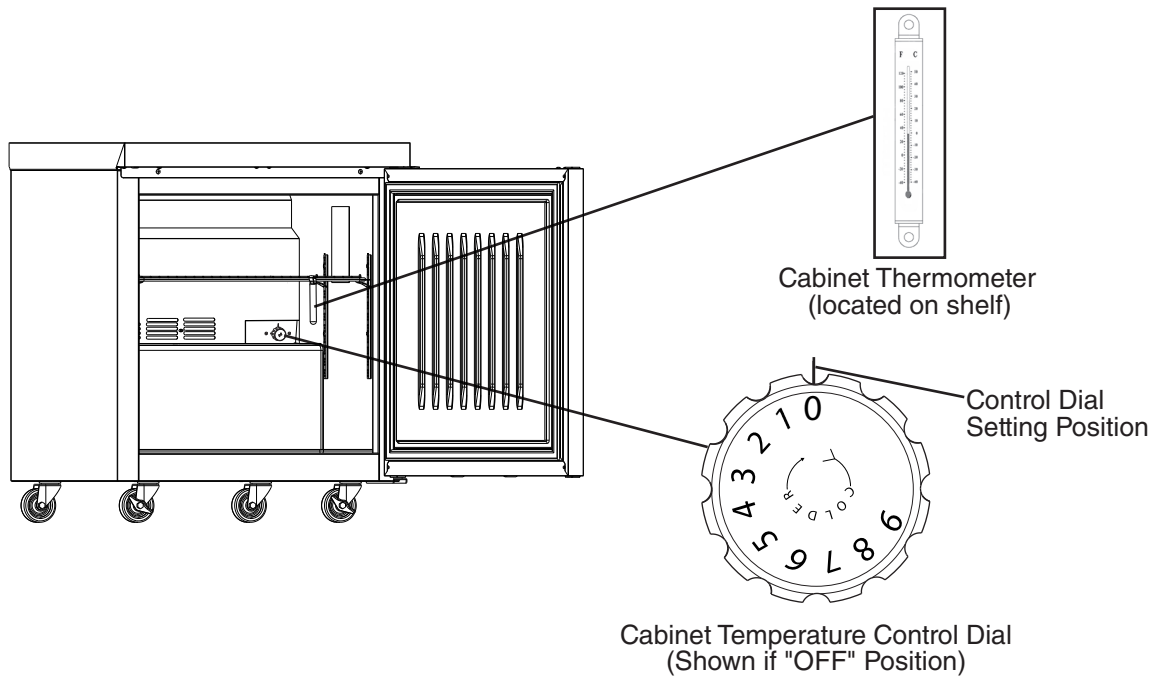

G. Defrost

There are 2 types of defrost: Off Cycle Defrost (with evaporator fan motor) and Heated Defrost (without evaporator fan motor).

Manual Initiation (All Models): Rotate the cabinet temperature control dial clockwise to position 9 (blue LED on and green LED flashing), counter-clockwise to position 1 (blue LED on and green LED flashing), clockwise to position 9 (blue and green LEDs flashing). Defrost initiates. See Fig. 2. Note: If not, move the cabinet temperature control dial back and forth until the LED turns on. Defrost initiated.

Cabinet Temperature Control Dial

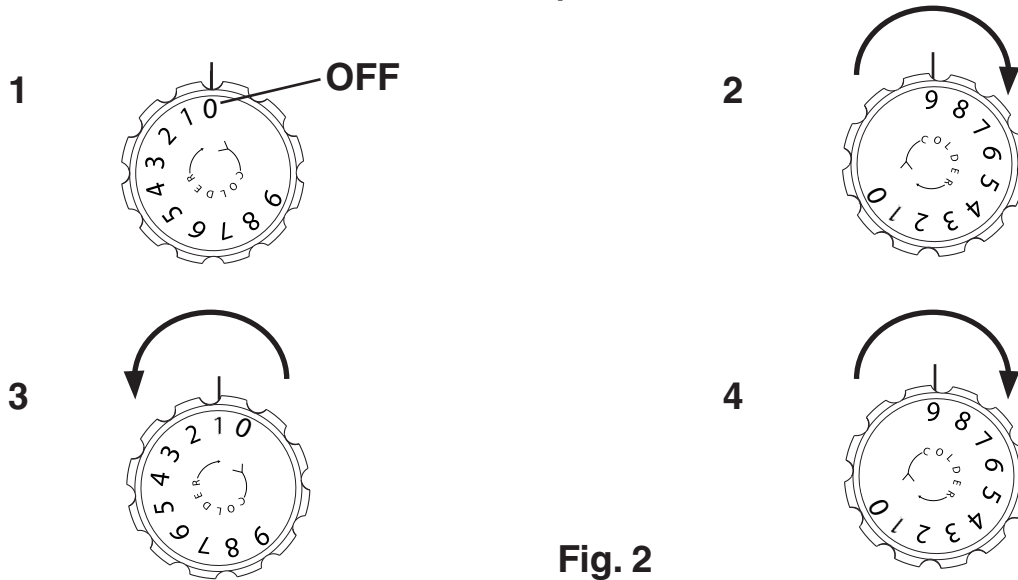

Fig. 2

Temperature Initiation: Evaporator temperature (defrost thermistor) achieves:

- UR/WR:** -4°F (-20°C) or lower.
- SR:** -31°F (-35°C) or lower.
- UF/WF:** -31°F (-35°C) or lower.

Defrost initiates. 1-hr. defrost lockout between defrost on UR/WR and UF/WF.

Time Initiation: 5-hr. cumulative compressor run timer terminates, defrost initiates.

- UR/WR:** 1-hr. maximum. Evaporator fan motor continues.
- SR:** 1-hr. maximum. Evaporator fan motor de-energizes.
- UF/WF:** 1-hr. maximum defrost timers starts. Evaporator fan motor de-energizes.

Manual Termination: Turn the CTCD to the "OFF" position, then back to original setting or unplug the appliance from the electrical outlet, then plug the appliance back into the electrical outlet. Defrost terminated.

Temperature/Time Termination: Evaporator termination temperature (defrost thermistor) achieved or backup maximum defrost timer terminates.

UR/WR: DTh warms to 45°F (7.2°C) or 1-hr. max. defrost timer terminates.

SR: DTh warms to 46°F (7.7°C) or 1-hr. max. defrost timer terminates.

UF/WF: DTh warms to 55°F (12.7°C) or 1-hr. max. defrost timer terminates.

H. Safety Devices

1. Compressor External Protector (All Models)

If combined temperature/amperage value is above the limit specified by the compressor manufacturer, the compressor external protector operates independently to turn off the compressor. The compressor external protector de-energizes the compressor until the temperature/amperage value returns to an acceptable level.

I. Perimeter and Mullion Heaters (UF/WF only)

UF/WF are equipped with perimeter and mullion heaters. If condensation occurs, check continuity of heaters.

IV. Refrigeration Circuit and Component Service Information

DANGER

Risk of Fire or Explosion. Flammable Refrigerant Used

- Follow handling instructions carefully in compliance with U.S. government regulations.
- Do not use mechanical devices to defrost.
- Do not puncture refrigerant tubing. Risk of fire or explosion due to puncture of refrigerant tubing; follow handling instructions carefully.
- Component parts shall be replaced with like components.
- Servicing shall be done by factory authorized service personnel to minimize the risk of possible ignition due to incorrect parts or improper service.
- Consult instruction manual/service manual before attempting to install or service this product.
- Dispose of properly in accordance with federal or local regulations.
- Do not place any potential ignition sources in or near the appliance.

Risque De Feu Ou D'Explosion. Fluide Frigorigène Inflammable Utilisé.

- Suivre attentivement les instructions de manipulation conformément à la réglementation gouvernementale.
- Ne pas utiliser d'appareils mécaniques pour dégivrer le réfrigérateur.
- Ne pas perforer la tubulure contenant le frigorigène. Risque de feu ou d'explosion si la tubulure contenant le frigorigène est perforée; suivre les instructions de manutention avec soin.
- Les pièces des composants doivent être remplacées par des pièces et accessoires équivalents.
- L'entretien doit être effectué par le personnel de service autorisé par le fabricant afin de minimiser les risques d'inflammation attribuables à l'installation d'une pièce inadéquate ou à la mauvaise exécution du service.
- Consulter le manuel du propriétaire/guide de réparation avant de tenter une réparation. Toutes les mesures de sécurité doivent être respectées.
- Éliminer conformément aux règlements fédéraux ou locaux.
- Ne placez aucune source d'inflammation potentielle dans ou près de l'appareil.

⚠ WARNING

- Wear appropriate personal protective equipment (PPE) when servicing the appliance.
- Technician must utilize a combustible gas leak detector at all times.
- Notify everyone in the immediate area that you are working with flammable refrigerant.
- Do not work on appliance in a confined space. Confirm area is well ventilated.
- Identify and eliminate all possible ignition points in a 10 ft. (3 m) area around service area.
- Do not use mechanical devices to defrost.
- Use non-sparking tools.
- Class B dry chemical fire extinguisher or equivalent must be available.
- Do not pressurize system above 200 PSIG during leak check procedure or prior to evacuating refrigeration system.
- This appliance should be diagnosed and repaired only by qualified service personnel to reduce the risk of death, electric shock, serious injury, or fire.
- To reduce the risk of electric shock, do not touch the plug with damp hands.
- Unplug the appliance from the electrical outlet before servicing.
- Make sure all food zones in the appliance are clean after the appliance is serviced.

A. Refrigeration Circuit Service Information

WARNING

- Repairs requiring the refrigeration circuit to be opened must be performed by properly trained and EPA-certified service personnel.
- Use an electronic leak detector or soap bubbles to check for leaks. Add a trace of refrigerant to the system (if using an electronic leak detector), and then raise the pressure using nitrogen gas (140 PSIG). Do not use R-290 as a mixture with pressurized air for leak testing.

NOTICE

- Always recover the refrigerant and store it in an approved container. Do not discharge the refrigerant into the atmosphere.
- Do not leave the system open for longer than 15 minutes when replacing or servicing parts. The Polyol Ester (POE) oils used in R-290 appliances can absorb moisture quickly. Therefore it is important to prevent moisture from entering the system when replacing or servicing parts.
- Always install a new drier every time the sealed refrigeration system is opened. Do not replace the drier until after all other repair or replacement has been made. Install the new drier with the arrow on the drier in the direction of the refrigerant flow.
- When brazing, protect the drier by using a wet cloth to prevent the drier from overheating. Do not allow the drier to exceed 250°F (121°C).

Refrigerant leaks must be repaired as soon as they are discovered. If not, refrigerant charge should be recovered from the system until the leak can be repaired.

When repairing a leak:

- Repair the leak properly – Remove the refrigerant, examine the leak source, determine the reason for the leak, and carry out the proper course of action.
- Before repairing the leak, ensure that the refrigerant has been recovered and the system purged with nitrogen when brazing.
- Be sure to remove piercing valves attached to the system after repairs are made.

a) Refrigerant Recovery

Using proper refrigerant practices, place piercing valves toward the end (crimped area) of the high and low-side process tubes, then recover the refrigerant into an approved container or device.

b) Brazing

- 2) Prior to brazing, purge with nitrogen gas for 2 min., flowing at a pressure of 3 to 5 PSIG.
⚠ DANGER! For appliances containing flammable refrigerants, the system shall be purged with oxygen-free nitrogen to render the appliance safe for flammable refrigerants. This process might need to be repeated several times. Compressed air or oxygen shall not be used for purging refrigerant systems.
- 3) Braze/repair/replace damaged component or fittings while purging with nitrogen gas, flowing at a pressure of 3 to 5 PSIG.
- 4) Use soap bubbles to check for leaks. Raise the pressure using nitrogen gas (190 PSIG). Do not use any refrigerant as a mixture with pressurized air for leak testing.
- 5) Once leak checking is complete, release the nitrogen gas from the system.

c) Evacuation

- 6) Attach a vacuum pump to the system. Be sure the high-side charging hose is connected to the field-installed high-side access valve.

<i>IMPORTANT</i>
The vacuum level and vacuum pump may be the same as those for current refrigerants. However, the rubber hose and gauge manifold to be used for evacuation and refrigerant charge should be exclusively for POE oils.

- | |
|--|
| The vacuum level and vacuum pump may be the same as those for current refrigerants. However, the rubber hose and gauge manifold to be used for evacuation and refrigerant charge should be exclusively for POE oils. |
|--|
- 7) Turn on the vacuum pump, then open the high-side valve on the gauge manifold. Never allow the oil in the vacuum pump to flow backwards.
 - 8) Allow the vacuum pump to pull down to a 29.9" Hg vacuum. Evacuating period depends on pump capacity.
 - 9) Close the high-side valve on the gauge manifold.
 - 10) Disconnect the gauge manifold hose from the vacuum pump and attach it to a refrigerant service cylinder. Remember to loosen the connection and purge the air from the hose. See the nameplate for the required refrigerant charge. Hoshizaki recommends only virgin refrigerant or reclaimed refrigerant which meets the requirements of AHRI Standard 700 (latest edition) be used.

d) Recharge

DANGER

- In addition to conventional charging procedures, the following requirements shall be followed:
 - Ensure that contamination of different refrigerants does not occur when using charging equipment. Hoses or lines shall be as short as possible to minimize the amount of refrigerant contained in them.
 - Cylinders shall be kept in an appropriate position according to the instructions.
 - Ensure that the refrigerating system is earthed (grounded) prior to charging the system with refrigerant.
 - Label the system when charging is complete (if not already).
 - Extreme care shall be taken not to overfill the refrigerating system.
- The system shall be leak-tested on completion of charging but prior to commissioning. A follow up leak test shall be carried out prior to leaving the site.

- En plus des procédures de charge conventionnelles, les exigences suivantes doivent être respectées :
 - S'assurer qu'aucune contamination de différents réfrigérants ne se produit lors de l'utilisation de l'équipement de charge. Les tuyaux ou conduites doivent être aussi courts que possible afin de minimiser la quantité de réfrigérant qu'ils contiennent.
 - Les bouteilles doivent être maintenues dans une position appropriée conformément aux instructions.
 - S'assurer que le système de réfrigération soit mis à la terre avant de charger le système avec du réfrigérant.
 - Étiqueter le système lorsque la charge est terminée (si cela n'a pas déjà été fait).
 - Il faut veiller à ne pas trop remplir le système de réfrigération.
- Avant de recharger le système, celui-ci doit être testé sous pression avec le gaz de purge approprié. Le système doit être soumis à un essai de fuite à la fin de la charge, mais avant la mise en service. Un test de contrôle de fuite doit être effectué avant de quitter le site.

- 11) R-290 can be charged in either the liquid or vapor state. Liquid charge is preferred. If refrigerant charging is done in the liquid state, place the service cylinder on the scales; **if the service cylinder is not equipped with a dip tube, invert the service cylinder, then place it on the scales.** Open the high-side valve on the gauge manifold
- 12) Allow the system to charge with liquid until the proper charge weight is met.
- 13) Close the high-side valve on the gauge manifold. If charging is complete, skip to step 10.

- 14) If necessary, add any remaining charge to the system through the low-side.
NOTICE! To prevent compressor damage, use a throttling valve or liquid dispensing device to add the remaining liquid charge through the low-side refrigerant access valve with the compressor running. Close the refrigerant cylinder valve and let the low-side refrigerant equalize to the system, then close the low-side manifold gauge.
- 15) Pinch off (crimp down) the process tubes just below the piercing valves.
- 16) Remove the piercing valves. Cut the process tubes to remove the piercing valve holes.
- 17) Confirm there are no leaks from the pinched off process tubes, then braze the process tubes closed. **▲ DANGER! Be sure there is no refrigerant leak before brazing.**
- 18) Use a combustible gas leak detector or soap bubbles to check for leaks again.
- 19) Place red sleeves over the process tubes.
- 20) Plug the appliance back into the electrical outlet

B. Component Service Information



R-290 Class A3 Flammable Refrigerant Used

⚠ DANGER

Risk of Fire or Explosion. Flammable Refrigerant Used.

- Be sure to follow all Important Safety Information located at the beginning of this manual and at the beginning of section "III.A. Safety Precautions When Servicing."
- Component parts shall be replaced with like components. So as to minimize the risk of possible ignition due to incorrect parts.
- This appliance should be diagnosed and repaired only by qualified service personnel to reduce the risk of death, electric shock, serious injury, or fire.
- Repair and maintenance to electrical components shall include initial safety checks and component inspection procedures. If a fault exists that could compromise safety, then no electrical supply shall be connected to the circuit until it is satisfactorily dealt with. If the fault cannot be corrected immediately but it is necessary to continue operation, an adequate temporary solution shall be used. This shall be reported to the owner of the equipment, so all parties are advised.
- Confirm that capacitors are discharged: this shall be done in a safe manner to avoid possibility of sparking.
- Confirm that no live electrical components and wiring are exposed while charging, recovering, or purging the system.
- Confirm that there is continuity of earth bonding (grounding).

⚠ DANGER Continué

Risque D'Incendie ou D'Explosion. Fluide Frigorigène Inflammable Utilisé.

- Assurez-vous de suivre toutes les informations importantes de sécurité qui se trouvent au début du présent manuel et au début de la section «III.A. Précautions de sécurité lors de l'entretien.»
- Les pièces doivent être remplacées par des pièces similaires, de manière à réduire au minimum le risque d'inflammation dû à des pièces incorrectes.
- Cet appareil ne doit être diagnostiqué et réparé que par un personnel qualifié afin de réduire les risques de mort, d'électrocution, de blessures graves ou d'incendie.
- La réparation et l'entretien des composants électriques incluent les contrôles de sécurité initiaux et les procédures d'inspection des composants. En cas de défaut susceptible de compromettre la sécurité, aucune alimentation électrique ne doit être connectée au circuit tant que le problème n'a pas été résolu de manière satisfaisante. Si le défaut ne peut être corrigé immédiatement mais qu'il est nécessaire de poursuivre l'exploitation, une solution temporaire adéquate doit être utilisée. Cela doit être signalé au propriétaire de l'équipement, afin que toutes les parties soient informées.
- S'assurer que les condensateurs sont déchargés : cette opération doit être effectuée en toute sécurité afin d'éviter tout risque d'étincelle.
- S'assurer qu'aucun composant ou câblage électrique sous tension n'est exposé lors de la charge, de la récupération ou de la purge du système.
- S'assurer de la continuité de la mise à la terre.

NOTICE

When replacing a component listed below, see the notes to help ensure proper operation.

Component	Notes
Compressor	Install a new start relay and compressor external protector. WARNING! To reduce the risk of electric shock, be sure to reconnect the compressor's ground wire.
Cabinet Thermistor	After working with or around the cabinet thermistor, make sure the cabinet thermistor is in its correct position and secure.
Defrost Thermistor	After working with or around the defrost thermistor on an SR or UF/WF, make sure the defrost thermistor wire is not touching the defrost heater and the defrost thermistor is in its correct position and secure.

V. Maintenance

This appliance must be maintained in accordance with the instruction manual and labels provided with the appliance. Consult with your local Hoshizaki Certified Service Representative about maintenance service.

WARNING

- Only qualified service technicians should service this appliance.
- Failure to install, operate, and maintain the appliance in accordance with this manual will adversely affect safety, performance, component life, and warranty coverage.
- Press the "U" button for 1-sec. to turn the control module off, then unplug the appliance from the electrical outlet.
- To reduce the risk of electric shock, do not touch the control module or plug with damp hands.
- After service, make sure that there are no wires pinched between the panels and appliance. Make sure you do not damage the power cord

A. Maintenance Schedule

The maintenance schedule below is a guideline. More frequent maintenance may be required depending on water quality, the appliance's environment, and local sanitation regulations.

Maintenance Schedule		
Frequency	Area	Task
Bi-Yearly	Condenser	Inspect. Clean if necessary by using a brush or vacuum cleaner. More frequent cleaning may be required depending on location.

VI. Preparing the Appliance for Periods of Non-Use

DANGER

Risk of Fire or Explosion. Flammable Refrigerant Used.

- Be sure to follow all Important Safety Information located at the beginning of this manual and at the beginning of section "III.A. Safety Precautions When Servicing."
- Only qualified service technicians should service this appliance.
- The appliance shall be stored in an area where the room size corresponds to the room area as specified for operation. See the nameplate or instruction manual for Minimum Room Floor Area.
- The appliance shall be stored in a room without continuously operating open flames (for example an operating gas appliance) or other potential ignition sources (for example an operating electric heater, hot surfaces).

Risque D'Incendie ou D'Explosion. Fluide Frigorigène Inflammable Utilisé.

- Assurez-vous de suivre toutes les informations importantes de sécurité qui se trouvent au début du présent manuel et au début de la section «III.A. Précautions de sécurité lors de l'entretien.»
- Seuls des techniciens de service qualifiés doivent installer et entretenir l'appareil.
- L'appareil doit être conservé dans une zone où la taille de la pièce correspond à la surface de la pièce spécifiée pour le fonctionnement.
- L'appareil doit être entreposé dans un local ne contenant pas de sources d'inflammation permanentes (flammes nues, appareil à gaz ou dispositif de chauffage électrique en fonctionnement, par exemple).

WARNING

When preparing the appliance for long storage, prevent the drawers from closing to reduce the risk of children getting trapped.

NOTICE

When preparing the appliance for long storage, clean the appliance. See the instruction manual for cleaning details.

- 1) Before shutting down the appliance, move all foods into another clean refrigerator or freezer.
- 2) Unplug the appliance. **WARNING! To reduce the risk of electric shock, do not touch the plug with damp hands.**

VII. Disposal and Decommissioning

DANGER

Risk of Fire or Explosion. Flammable Refrigerant Used.

- Follow handling instructions carefully in compliance with U.S. government regulations.
- Do not puncture refrigerant tubing. Risk of fire or explosion due to puncture of refrigerant tubing; follow handling instructions carefully.
- Dispose of properly in accordance with federal or local regulations.

Risque De Feu Ou D'Explosion. Fluide Frigorigène Inflammable Utilisé.

- Suivre attentivement les instructions de manipulation conformément à la réglementation gouvernementale.
- Ne pas perforer la tubulure contenant le frigorigène. Risque de feu ou d'explosion si la tubulure contenant le frigorigène est perforée; suivre les instructions de manutention avec soin.
- Éliminer conformément aux règlements fédéraux ou locaux.

WARNING

When preparing the appliance for disposal, remove the drawers to reduce the risk of children getting trapped.

The appliance contains refrigerant and must be disposed of in accordance with applicable national, state, and local codes and regulations. Refrigerant must be recovered by properly certified service personnel.

VIII. Technical Information

A. Electrical and Refrigerant Data

Model Number	UR/WR27B(-D2)(-01)(-LP)(-LPW)(-LPC)(-LPL)(-LPCL)(-LP01)(-LPD2)(-LPD3)(-GLP01)(-8)(-8D2)(-8FL)(-8D2FL)(-12M)(-12MD2)(-12MFL)(-12MD2FL)
AC SUPPLY VOLTAGE	~115/60/1
AMPERES	3.0
DESIGN PRESSURE kPa (PSI)	HI-2482 (360) LO-1310 (190)
REFRIGERANT g (oz.)	R-290 65 (2.3)
CLIMATIC CLASS	5
INSULATION BLOWING GAS	HFO 1233zd(E)
MINIMUM ROOM FLOOR AREA m ² (ft ²)	3.1 (33.5)
Model Number	UR/WR36B(-01)(-LP)(-LP01)(-10)(-10FL)(-15M)(-15MFL)
AC SUPPLY VOLTAGE	~115/60/1
AMPERES	3.0
DESIGN PRESSURE kPa (PSI)	HI-2482 (360) LO-1310 (190)
REFRIGERANT g (oz.)	R-290 65 (2.3)
CLIMATIC CLASS	5
INSULATION BLOWING GAS	HFO 1233zd(E)
MINIMUM ROOM FLOOR AREA m ² (ft ²)	3.1 (33.5)
Model Number	UR/WR48B(-01)(-Dx)(-LP)(-LP01)(-GLP01)(-LPDx)
AC SUPPLY VOLTAGE	~115/60/1
AMPERES	3.0
DESIGN PRESSURE kPa (PSI)	HI-2482 (360) LO-1310 (190)
REFRIGERANT g (oz.)	R-290 60 (2.1)
CLIMATIC CLASS	5
INSULATION BLOWING GAS	HFO 1233zd(E)
MINIMUM ROOM FLOOR AREA m ² (ft ²)	2.9 (30.9)
Model Number	SR48B-8(-8FL)(-12)(-12FL)(-12M)(-12MFL)(-12Dx)(-12DxFL)(-18M)(-18MFL)(-18MDx)(-18MDxFL)
AC SUPPLY VOLTAGE	~115/60/1
AMPERES	3.0
DESIGN PRESSURE kPa (PSI)	HI-2482 (360) LO-1310 (190)
REFRIGERANT g (oz.)	R-290 73 (2.6)
CLIMATIC CLASS	5
INSULATION BLOWING GAS	HFO 1233zd(E)
MINIMUM ROOM FLOOR AREA m ² (ft ²)	3.5 (37.6)
Model Number	UR/WR60B(-01)(-Dx)(-LP)(-LP01)(-LPDx)
AC SUPPLY VOLTAGE	~115/60/1
AMPERES	3.0
DESIGN PRESSURE kPa (PSI)	HI-2482 (360) LO-1310 (190)
REFRIGERANT g (oz.)	R-290 65 (2.3)
CLIMATIC CLASS	5
INSULATION BLOWING GAS	HFO 1233zd(E)
MINIMUM ROOM FLOOR AREA m ² (ft ²)	3.1 (33.5)

Model Number	SR60B-8(-8FL)(-12)(-12FL)(-12M)(-12MFL)(-16)(-16FL)(-18M)(-18MFL)(-18MFC)(-24M)(-24MFC)(-24MFL)(-24MDx)(-24MDxFL)
AC SUPPLY VOLTAGE	~115/60/1
AMPERES	4.0
DESIGN PRESSURE kPa (PSI)	HI-2482 (360) LO-1310 (190)
REFRIGERANT g (oz.)	R-290 70 (2.5)
CLIMATIC CLASS	5
INSULATION BLOWING GAS	HFO 1233zd(E)
MINIMUM ROOM FLOOR AREA m ² (ft ²)	3.3 (36.1)

Model Number	UR72B(-LP)
AC SUPPLY VOLTAGE	~115/60/1
AMPERES	3.0
DESIGN PRESSURE kPa (PSI)	HI-2482 (360) LO-1310 (190)
REFRIGERANT g (oz.)	R-290 75 (2.6)
CLIMATIC CLASS	5
INSULATION BLOWING GAS	HFO 1233zd(E)
MINIMUM ROOM FLOOR AREA m ² (ft ²)	3.6 (38.6)

Model Number	UR/WR72B(-01)(-D6)(-LP01)(-LPD6)
AC SUPPLY VOLTAGE	~115/60/1
AMPERES	3.5
DESIGN PRESSURE kPa (PSI)	HI-2482 (360) LO-1310 (190)
REFRIGERANT g (oz.)	R-290 75 (2.6)
CLIMATIC CLASS	5
INSULATION BLOWING GAS	HFO 1233zd(E)
MINIMUM ROOM FLOOR AREA m ² (ft ²)	3.6 (38.6)

Model Number	SR72B-12(-12FL)(-16)(-16FL)(-18)(-18FL)(-18M)(-18MFL)(-24M)(-24MFL)(-30M)(-30MFL)(-30MDx)(-30MDxFL)
AC SUPPLY VOLTAGE	~115/60/1
AMPERES	4.0
DESIGN PRESSURE kPa (PSI)	HI-2482 (360) LO-1310 (190)
REFRIGERANT g (oz.)	R-290 75 (2.6)
CLIMATIC CLASS	5
INSULATION BLOWING GAS	HFO 1233zd(E)
MINIMUM ROOM FLOOR AREA m ² (ft ²)	3.6 (38.6)

2. Freezers

Model Number	UF/WF27B(-01)(-D2)(-LP)(-LPL)(-LP01)(-LPD2)(-GLP01)
AC SUPPLY VOLTAGE	~115/60/1
AMPERES	3.0
DESIGN PRESSURE kPa (PSI)	HI-2482 (360) LO-1310 (190)
REFRIGERANT g (oz.)	R-290 55 (1.9)
CLIMATIC CLASS	5
INSULATION BLOWING GAS	HFO 1233zd(E)
MINIMUM ROOM FLOOR AREA m ² (ft ²)	2.6 (28.3)

Model Number	UF/WF48B(-01)(-Dx)(-D2W)(-LP)(-LP01)(-LPDx)
AC SUPPLY VOLTAGE	~115/60/1
AMPERES	4.0
DESIGN PRESSURE kPa (PSI)	HI-2482 (360) LO-1310 (190)
REFRIGERANT g (oz.)	R-290 73 (2.6)
CLIMATIC CLASS	5
INSULATION BLOWING GAS	HFO 1233zd(E)
MINIMUM ROOM FLOOR AREA m ² (ft ²)	3.5 (37.6)

Model Number	UF/WF60B(-01)(-LP)(-LP01)
AC SUPPLY VOLTAGE	~115/60/1
AMPERES	4.0
DESIGN PRESSURE kPa (PSI)	HI-2482 (360) LO-1310 (190)
REFRIGERANT g (oz.)	R-290 75 (2.6)
CLIMATIC CLASS	5
INSULATION BLOWING GAS	HFO 1233zd(E)
MINIMUM ROOM FLOOR AREA m ² (ft ²)	3.6 (38.6)

See the nameplate for electrical and refrigeration specifications. The nameplate is located inside the cabinet.

We reserve the right to make changes in specifications and design without prior notice.

Legend: U/WR—undercounter/worktop refrigerator

SR—prep table

U/WF—undercounter/worktop freezer

B. Wiring Diagrams

1. UR/WR27 (Glass Door), UR/WR36, UR/WR48, and SR36

R290 REFRIGERATOR
 27/36/48 UNDERCOUNTER / WORKTOP
 27 GLASS DOOR
 36 OPEN TOP

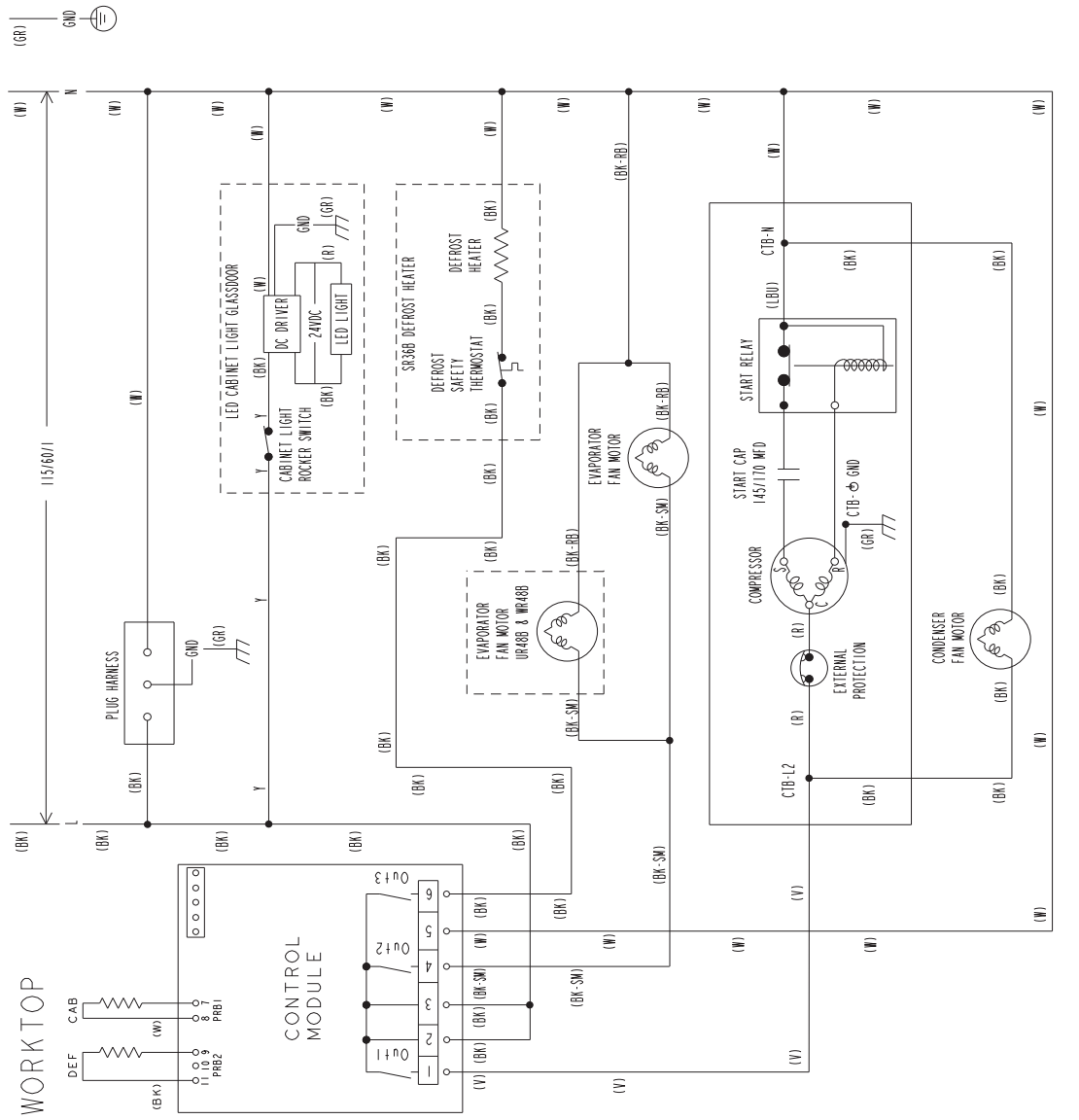

LED OPERATION	LED STATUS
SYSTEM ON	GREEN FLASHING
SYSTEM IM STANDBY	RED ON
ALARM ACTIVE	RED FLASHING
COMPRESSOR ON	BLUE ON
DEFROSTING	BLUE FLASHING

WIRE COLOR CODE	
BK	BLACK
BK-SM	BLACK SMOOTH
BK-RB	BLACK RIBBED
BR	BROWN
DBU	DARK BLUE
GR	GREEN
GY	GRAY
LBU	LIGHT BLUE
O	ORANGE
P	PINK
R	RED
V	VIOLET
W	WHITE
Y	YELLOW

CTB = COMPRESSOR COVER TERMINAL BLOCK	
L1	NOT USED
L2	L LINE
N	NEUTRAL
	GROUND

2. UR/WR60, UR/WR72, UR48 (Glass Door)

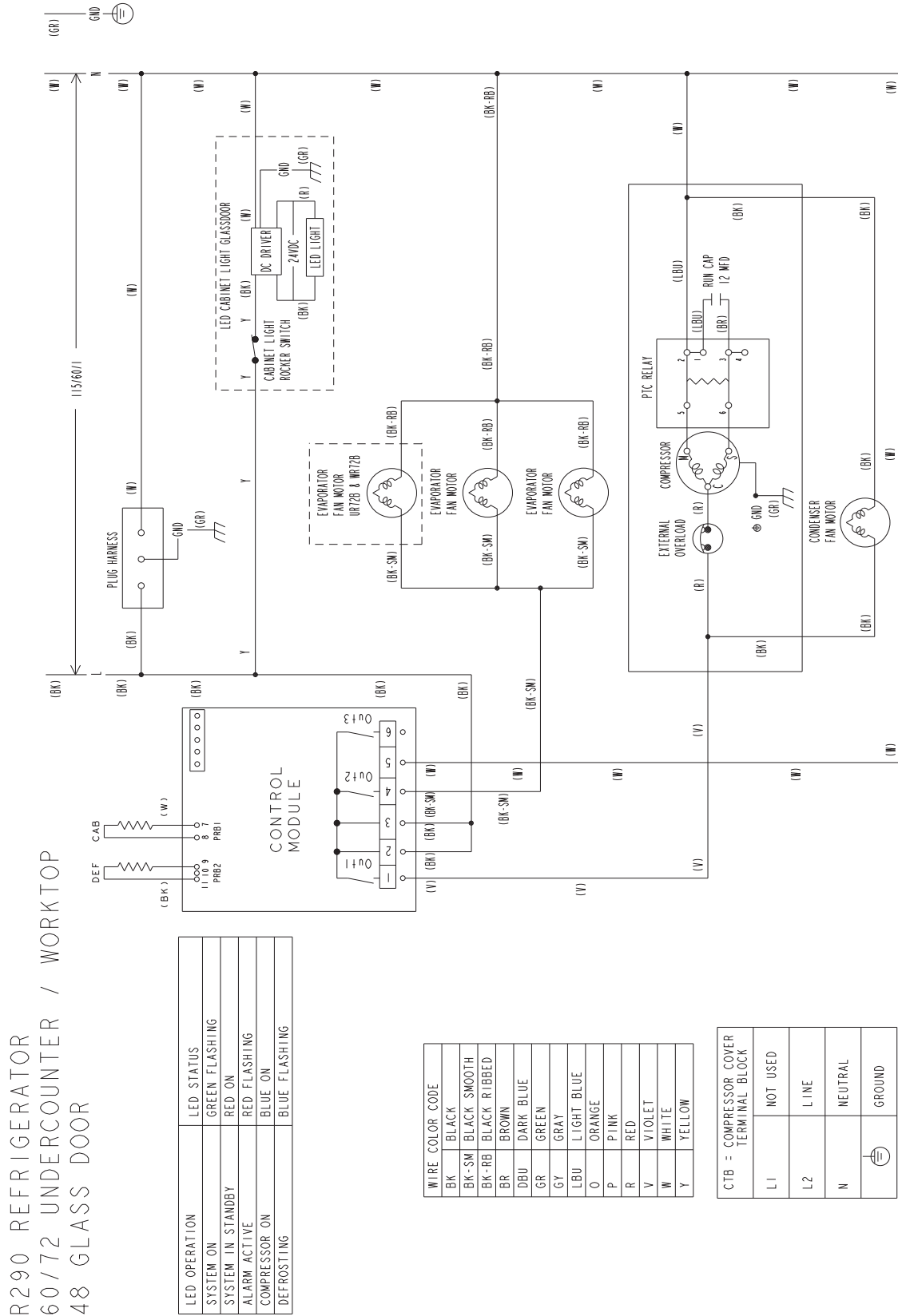

3. UF/WF27 (Glass Door), SR27, and SR48

R290 FREEZER
 27 UNDERCOUNTER / WORKTOP
 27 GLASS DOOR
 R290 REFRIGERATOR
 27/48 OPEN TOP

LED OPERATION	LED STATUS
SYSTEM ON	GREEN FLASHING
SYSTEM IN STANDBY	RED ON
ALARM ACTIVE	RED FLASHING
COMPRESSOR ON	BLUE ON
DEFROSTING	BLUE FLASHING

WIRE COLOR CODE	
BK	BLACK
BK-SM	BLACK SMOOTH
BK-RB	BLACK RIBBED
BR	BROWN
DBU	DARK BLUE
GR	GREEN
GY	GRAY
LBU	LIGHT BLUE
O	ORANGE
P	PINK
R	RED
V	VIOLET
W	WHITE
Y	YELLOW

CTB = COMPRESSOR COVER TERMINAL BLOCK	
L1	NOT USED
L2	LINE
N	NEUTRAL
	GROUND

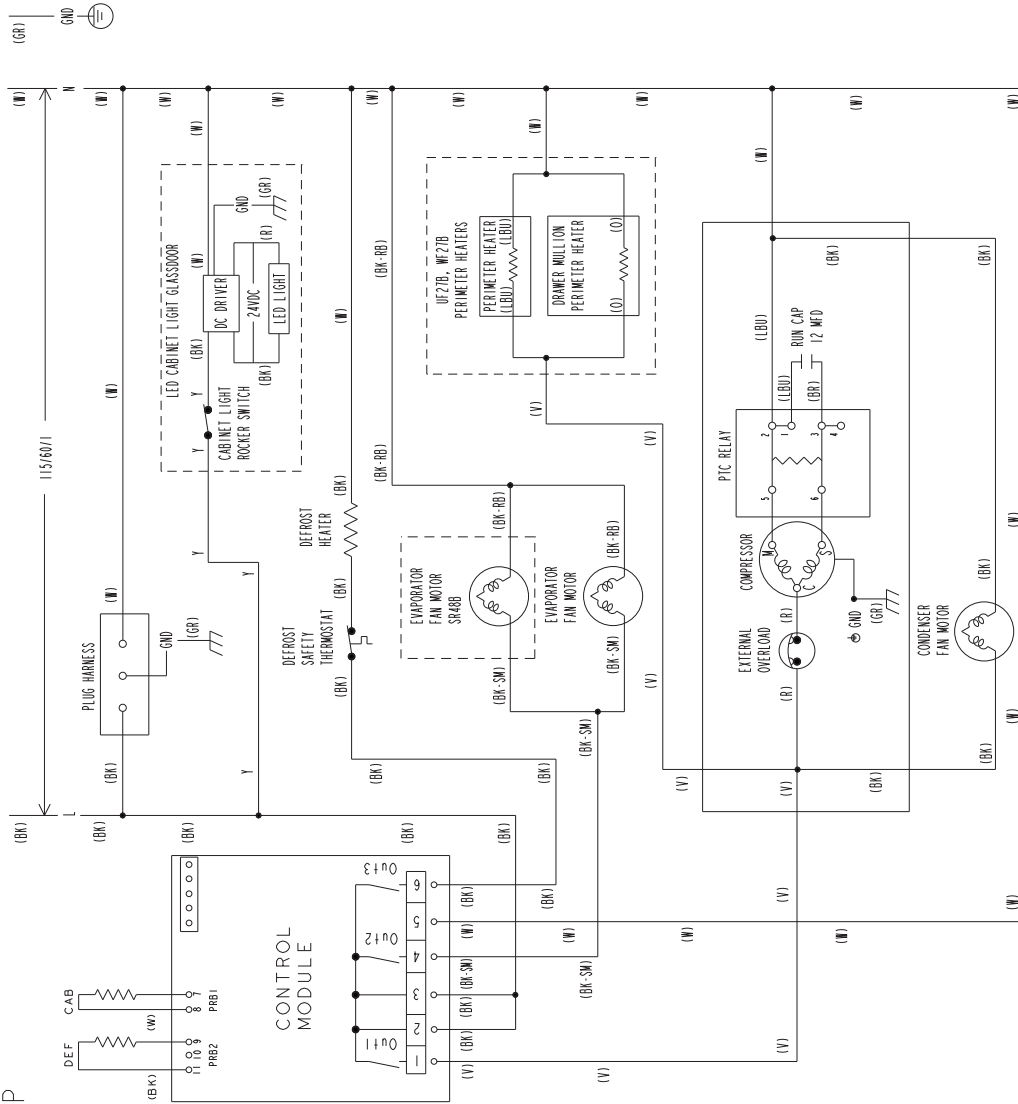

4. UF/WF48, UF/WF60, SR60, and SR72

R290 FREEZER
48/60 UNDERCOUNTER / WORKTOP
R290 REFRIGERATOR
60/72 OPEN TOP

LED OPERATION	LED STATUS
SYSTEM ON	GREEN FLASHING
SYSTEM IN STANDBY	RED ON
ALARM ACTIVE	RED FLASHING
COMPRESSOR ON	BLUE ON
DEFROSTING	BLUE FLASHING

WIRE COLOR CODE	
BK	BLACK
BK-SM	BLACK SMOOTH
BK-RB	BLACK RIBBED
BR	BROWN
DBU	DARK BLUE
GR	GREEN
GY	GRAY
LBU	LIGHT BLUE
O	ORANGE
P	PINK
R	RED
V	VIOLET
W	WHITE
Y	YELLOW

CTB = COMPRESSOR COVER TERMINAL BLOCK	
L1	NOT USED
L2	L LINE
N	NEUTRAL
	GROUND

