



HOSHIZAKI

Instruction Manual

Steelheart Series
Refrigerated Kitchen Equipment

Models
Upright Freezer A-Series



hoshizakiamerica.com

Issued: 11-5-2025
Revised: 6-9-2026

⚠ WARNING

Only qualified service technicians should install and service the appliance. To obtain the name and phone number of your local Hoshizaki Certified Service Representative, visit www.hoshizakiamerica.com. No installation, operation, or maintenance should be undertaken until the technician has thoroughly read this Instruction Manual. No service should be undertaken until the technician has thoroughly read the service manual available at www.hoshizakiamerica.com. Likewise, the owner/manager should not proceed to operate the appliance until the installer has instructed them on its proper operation. Failure to install, operate, and maintain the appliance in accordance with this manual may adversely affect safety, performance, component life, and warranty coverage. Proper installation is the responsibility of the installer. Product failure or property damage due to improper installation is not covered under warranty.

Hoshizaki provides this manual primarily to assist qualified service technicians in the installation, operation, maintenance, and service of the appliance.

Should the reader have any questions or concerns which have not been satisfactorily addressed, please call, send an e-mail message, or write to the Hoshizaki Technical Support Department for assistance.

Phone: 1-800-233-1940; (770) 487-2331

E-mail: tech-support@hoshizakiamerica.com

HOSHIZAKI AMERICA, INC.

618 Highway 74 South
Peachtree City, GA 30269
Attn: Hoshizaki Technical Support Department

NOTE: To expedite assistance, all correspondence/communication **MUST** include the following information:

- Model Number _____
- Serial Number _____
- Complete and detailed explanation of the problem.

IMPORTANT

This manual should be read carefully before the appliance is installed and operated. Read the warnings and guidelines contained in this manual carefully as they provide essential information for the continued safe use and maintenance of the appliance. Retain this manual for any further reference that may be necessary.

CONTENTS

Important Safety Information	4
I. Specifications.....	10
A. Construction.....	10
B. Electrical and Refrigerant Data	11
II. Installation Instructions	13
A. Location	13
B. Checks Before Installation.....	15
C. Setup.....	16
D. DT1A-HS Heated Condensate Pan Installation.....	17
E. Food Cart Ramp (Roll-In/Roll-Thru Appliances).....	19
F. Door Reversal	21
1. Full Solid Door and Full FGE Glass Door Reversal.....	21
2. Half Solid Door and Half HGE Glass Door Reversal	24
G. Electrical Connection	29
H. Final Checklist.....	30
III. Operating Instructions.....	31
A. Important Notes About Usage	31
B. Startup	33
C. Controls and Adjustments	33
1. Temperature Display.....	33
2. Adjusting the Temperature Setpoint	34
3. Light Control for Glass Door Models.....	34
D. Control Module Buttons and Icons	35
E. Defrost.....	36
F. Food Storage	38
G. Alarm Safeties.....	39
H. Safety Devices	40
I. Cooling Performance	40
J. Cabinet Condensation	40
IV. Maintenance	41
A. Maintenance Schedule.....	41
B. Cleaning Instructions	42
V. Preparing the Appliance for Periods of Non-Use	44
VI. Decommissioning and Disposal	45

Important Safety Information

Throughout this manual, notices appear to bring your attention to situations which could result in death, serious injury, damage to the appliance, or damage to property.

	R-290 Class A3 Flammable Refrigerant Used
⚠ DANGER	Indicates a hazardous situation that, if not avoided, will result in death or serious injury.
⚠ WARNING	Indicates a hazardous situation that, if not avoided, could result in death or serious injury.
NOTICE	Indicates a situation that, if not avoided, could result in damage to the appliance or property.
IMPORTANT	Indicates important information about the use and care of the appliance.

⚠ DANGER

Risk of Fire or Explosion **Flammable Refrigerant Used**

- | | |
|---|--|
| <ul style="list-style-type: none"> • Only qualified service technicians should install and service the appliance. • No installation, operation, or maintenance should be undertaken until the technician has thoroughly read this Instruction Manual. All safety precautions must be followed. • No service should be undertaken until the technician has thoroughly read the Service Manual available at www.hoshizakiamerica.com. All safety precautions must be followed. • This appliance to be installed in accordance with the Safety Standard for Refrigeration Systems ANSI/ASHRAE 15. • Follow handling instructions carefully in compliance with national regulations. • Do not use mechanical devices or other means to accelerate the defrosting process or to clean, other than those recommended by the manufacturer. • Do not puncture refrigerant tubing. Risk of fire or explosion due to puncture of refrigerant tubing; follow handling instructions carefully. | <ul style="list-style-type: none"> • Servicing shall be done by trained service personnel with certified competence in handling flammable refrigerants to minimize the risk of possible ignition due to incorrect parts or improper service. • Component parts shall be replaced with like components so as to minimize the risk of possible ignition due to incorrect parts. • Dispose of properly in accordance with federal or local regulations. • Do not pierce or burn. • Be aware that refrigerants may not contain an odor. • Do not damage the refrigeration circuit. • See nameplate for R-290 refrigerant charge: <ul style="list-style-type: none"> • If greater than 114 g (4 oz.), do not install in public corridor or lobby. • If greater than 152 g (5.3 oz.), do not install within 6 m (20 ft) of open flame. |
|---|--|

⚠ DANGER continued

- The appliance shall be stored in a room without continuously operating ignition sources (for example: open flames, an operating gas appliance, or an operating electric heater).
- Do not place any potential ignition sources in or near the appliance.
- Keep clear of obstruction all ventilation openings in the appliance enclosure or in the structure for building-in.
- No potential sources of ignition are to be used in the searching for or detection of refrigerant leaks.
- Do not use electrical appliances inside the appliance unless they are of the type recommended by the manufacturer.
- Do not store explosive substances such as aerosol cans with a flammable propellant in this appliance.
- Check that cabling will not be subject to wear, corrosion, excessive pressure, vibration, sharp edges, or any other adverse environmental effects. The check shall also take into account the effects of aging or continual vibration from sources such as compressors or fans.
- Ensure that the area is in the open or that it is adequately ventilated before breaking into the system or conducting any hot work. A degree of ventilation shall continue during the period that the work is carried out. The ventilation should safely disperse any released refrigerant and preferably expel it externally into the atmosphere.



**Risque D'Incendie ou D'Explosion
Fluide Frigorigène Inflammable Utilisé**

- Seuls des techniciens de service qualifiés doivent installer et entretenir l'appareil.
- Aucune installation, opération ou maintenance ne doit être entreprise avant que le technicien n'ait lu attentivement ce manuel d'instructions. Toutes les précautions de sécurité doivent être suivies.
- Aucune opération d'entretien ne doit être entreprise avant que le technicien n'ait lu attentivement le manuel d'entretien disponible sur le site www.hoshizakiamerica.com. Toutes les précautions de sécurité doivent être suivies.
- Cet appareil doit être installé conformément à la norme de sécurité pour les systèmes de réfrigération ANSI/ASHRAE 15.
- Suivez attentivement les instructions de manutention conformément aux règlements nationaux.
- Ne pas utiliser de dispositifs mécaniques ou d'autres moyens pour accélérer le processus de dégivrage ou pour nettoyer, autres que ceux recommandés par le fabricant.
- Ne pas perforer la conduite de fluide frigorigène. Risque d'incendie ou d'explosion en cas de perforation d'une canalisation de fluide frigorigène; suivez attentivement les instructions de manutention.
- L'entretien doit être effectué par du personnel formé et certifié pour la manipulation de réfrigérants inflammables afin de réduire au minimum le risque d'inflammation dû à des pièces incorrectes ou à un entretien inadéquat.

⚠ DANGER continued

- Les pièces doivent être remplacées par des pièces similaires, de manière à réduire au minimum le risque d'inflammation dû à des pièces incorrectes.
 - Mettre au rebut conformément aux règlements fédéraux ou locaux.
 - Ne pas percer ou brûler.
 - Attention, les fluides frigorigènes peuvent ne pas dégager d'odeur.
 - Ne pas endommager les composants du circuit de réfrigération.
 - Voir plaque signalétique pour la charge de réfrigérant R-290:
 - Si elle est supérieure à 114 g (4 oz.), ne pas l'installer dans un couloir public ou un hall d'entrée.
 - Si elle est supérieure à 152 g (5.3 oz.), ne pas l'installer à moins de 6 m (20 pi) d'une flamme nue.
 - L'appareil doit être entreposé dans un local ne contenant pas de sources d'inflammation permanentes (flammes nues, appareil à gaz ou dispositif de chauffage électrique en fonctionnement, par exemple).
 - Ne placer aucune source d'inflammation potentielle à l'intérieur ou à proximité de l'appareil.
 - Ne pas obstruer les ouvertures de ventilation dans l'enceinte de l'appareil ou dans la structure d'encastrement.
 - Aucune source potentielle d'inflammation ne doit être utilisée pour rechercher ou détecter des fuites de réfrigérant.
 - Ne pas utiliser d'appareils électriques à l'intérieur de l'appareil, sauf s'ils sont du type recommandé par le fabricant.
 - Ne pas entreposer dans cet appareil des substances explosives telles que des bombes aérosols contenant un gaz propulseur inflammable.
- Vérifier que le câblage ne sera pas soumis à l'usure, à la corrosion, à une pression excessive, à des vibrations, à des arêtes vives ou à tout autre effet environnemental négatif. Le contrôle doit également prendre en compte les effets du vieillissement ou des vibrations continues provenant de sources telles que les compresseurs ou les ventilateurs.
 - S'assurer que la zone est à l'air libre ou qu'elle est correctement ventilée avant de pénétrer dans le système ou d'effectuer un travail à chaud. Une certaine ventilation doit être maintenue pendant la durée des travaux. La ventilation doit permettre de disperser en toute sécurité tout réfrigérant libéré et, de préférence, de l'expulser dans l'atmosphère.

WARNING

- The appliance should be destined only to the use for which it has been expressly conceived. Any other use should be considered improper and therefore dangerous. The manufacturer cannot be held responsible for injury or damage resulting from improper, incorrect, and unreasonable use. Failure to install, operate, and maintain the appliance in accordance with this manual will adversely affect safety, performance, component life, and warranty coverage and may result in costly water damage.
To reduce the risk of death, electric shock, serious injury, or fire, follow basic precautions including the following:
- This appliance is not intended for use above 2,000 m (6,561 ft). Installation above 2,000 m (6,561 ft) may adversely affect safety, performance, and component life.
- Wear appropriate personal protective equipment (PPE) when servicing the appliance.
- The appliance must be installed in accordance with applicable national, state, and local codes and regulations.
- The appliance requires an independent power supply of proper capacity. See the nameplate for electrical specifications. Failure to use an independent power supply of proper capacity can result in a tripped breaker, blown fuse, damage to existing wiring, or component failure. This could lead to heat generation or fire.
- **115VAC Models: THIS APPLIANCE MUST BE GROUNDED.** The appliance is equipped with a NEMA 5-15 three-prong grounding plug  to reduce the risk of potential shock hazards. It must be plugged into a properly grounded, independent 3-prong wall outlet. If the outlet is a 2-prong outlet, it is your personal responsibility to have a qualified electrician replace it with a properly grounded, independent 3-prong wall outlet. Do not remove the ground prong from the power cord and do not use an adapter plug. Failure to follow these instructions may result in death, electric shock, or fire.
- **208-230VAC Models: THIS APPLIANCE MUST BE GROUNDED:** This appliance is equipped with a NEMA L14-20 four-prong locking, grounding plug  to reduce the risk of potential shock hazards. It must be plugged into a properly grounded, independent 4-prong wall outlet. If the outlet is a 3-prong outlet or a 4-prong non-locking outlet, it is your personal responsibility to have a qualified electrician replace it with a properly grounded, independent 4-prong locking wall outlet. Do not remove the ground prong from the plug and do not use an adapter plug. After plugging in, twist the plug clockwise to lock it into place. Failure to follow these instructions may result in death, electric shock, or fire.
- To reduce the risk of electric shock, do not touch the control module or plug with damp hands.
- To reduce the risk of electric shock, make sure the appliance is off before plugging in or unplugging the appliance.
- Unplug the appliance before servicing.

⚠ WARNING continued

- Do not use an appliance with a damaged power cord. The power cord should not be altered, jerked, bundled, weighed down, pinched, or tangled. Such actions could result in electric shock or fire. To unplug the appliance, be sure to pull the plug, not the cord, and do not jerk the cord.
- Do not use an extension cord.
- If the supply cord is damaged, it must be replaced by the manufacturer, its service agent, or similarly qualified persons in order to avoid a hazard. Upon replacement, the GREEN ground wire in the power cord must be connected to the designated grounding screw.
- Do not make any alterations to the appliance. Alterations could result in electric shock, injury, fire, or damage to the appliance.
- Appliance is heavy. Use care when lifting or positioning. Work in pairs when needed to prevent injury or damage.
- The appliance is not intended for use by persons (including children) with reduced physical, sensory, or mental capabilities, or lack of experience and knowledge, unless they have been given supervision or instruction concerning use of the appliance by a person responsible for their safety.
- Do not splash, pour, or spray water directly onto or into the appliance. This might cause short circuit, electric shock, corrosion, or failure.
- Children should be supervised to ensure that they do not play with the appliance.
- Do not climb, stand, or hang on the appliance or allow children or animals to do so. Serious injury could occur or the appliance could be damaged.
- Be careful not to pinch fingers when opening and closing the door. Be careful when opening and closing the door when children are in the area.
- Open and close the doors with care. Opening the doors too quickly or forcefully may cause injury or damage to the appliance or surrounding equipment.
- Do not use combustible spray or place volatile or flammable substances in or near the appliance. They might catch fire.
- Do not throw anything onto the shelves or load any single shelf with more than 120 lb. (54.5 kg) of product. They might fall off and cause injury.
- The appliance is designed only for temporary storage of food. Employ sanitary methods. Use for any other purposes (for example, storage of chemicals or medical supplies such as vaccine and serum) could cause deterioration of stored items.
- Do not place any product on the floor of the cabinet. All product must be placed on properly installed shelves.
- Do not block air inlets or outlets, otherwise, cooling performance may be reduced.
- Do not tightly pack the cabinet. Allow some space between items to ensure good air flow. Also allow space between items and interior surfaces.
- Do not put warm or hot foods in the cabinet. Let them cool first, or they will raise the cabinet temperature and could deteriorate other foods in the cabinet or overload the appliance.
- Food storage and handling must comply with applicable codes and regulations.
- All foods should be wrapped in plastic film or stored in sealed containers. Otherwise, foods may dry up, pass their smells onto other foods, cause frost to develop, result in poor appliance performance, or increase the likelihood of cross-contamination. Certain dressings and food ingredients, if not stored in sealed containers, may accelerate corrosion of the evaporator, resulting in failure.

⚠ WARNING continued

- Do not store items near air outlets. Otherwise, items may freeze up and crack or break causing a risk of injury or contamination of other food.
- Do not place more than 20 lb. (9 kg) on the top panel. Items must be stable and secure to prevent items from falling off of the appliance.
- Care should be used when placing items on top of the appliance. Do not store liquid containers or items that could fall through the louvers on top of the appliance. This could cause electric shock or fire.

NOTICE

- Install the appliance in a location that stays above freezing. Normal operating ambient temperature must be within 45°F to 100°F (7°C to 38°C).
- Do not leave the appliance on during extended periods of non-use, extended absences, or in sub-freezing temperatures. To properly prepare the appliance for these occasions, follow the instructions in "V. Preparing the Appliance for Periods of Non-Use."
- Do not place objects on top of the appliance.
- Protect the floor when moving the appliance to prevent damage to the floor.
- Do not allow the appliance to bear any outside weight.
- Keep ventilation openings, in the appliance enclosure or in the built-in structure, clear of obstruction.
- Do not allow the appliance to bear any outside weight.
- To prevent deformation or cracks, do not spray insecticide onto the plastic parts or let them come into contact with oil.
- To avoid damage to the gasket, use only the door handle when opening and closing.

I. Specifications

A. Construction

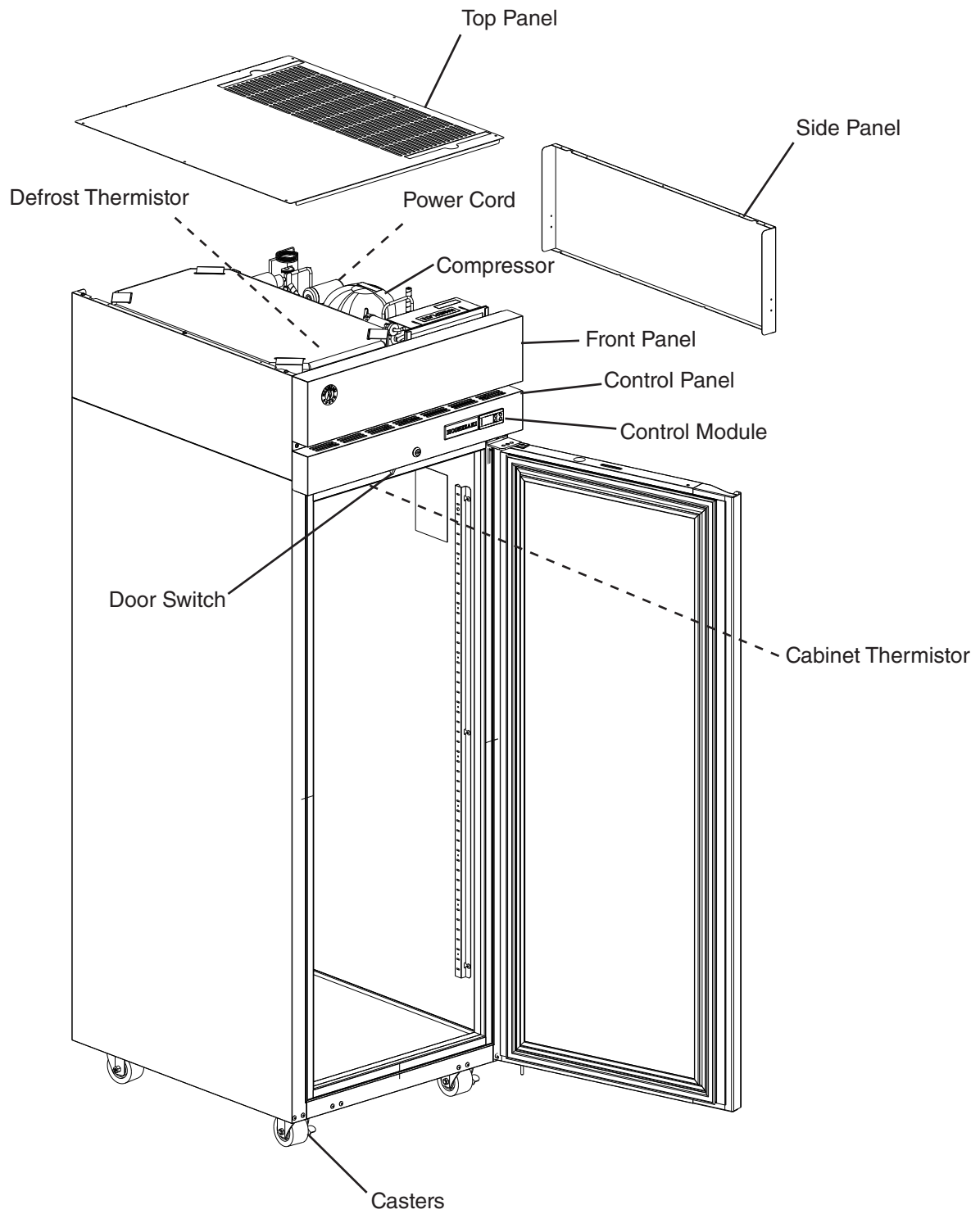

Model Shown: F1A-FS

B. Electrical and Refrigerant Data

The nameplate provides electrical and refrigerant data and Year of Manufacture (YOM). The nameplate is located on the rear panel. For certification marks, see the nameplate.

We reserve the right to make changes in specifications and design without prior notice.

Model Number	R1A-FGE(-FGECL)(-FGE CR) (-HGE)(-FS)(-FSJ)(-FSL)(-FSLJ) (-FSCL)(-FD CR)(-HS)(-HSL)	R2A-FGE(-HGE)(-FS)(-HS) (-FSN)(-FSC)
AC SUPPLY VOLTAGE	DATA PENDING	
AMPERES		
DESIGN PRESSURE kPa (PSI)		
REFRIGERANT g (oz.)		
CLIMATIC CLASS		
INSULATION BLOWING GAS		
MINIMUM ROOM FLOOR AREA m ² (ft ²)		

Model Number	R3A-FGE(-HGE)(-FS)(-FSCL)(-FSCR)(-HS)
AC SUPPLY VOLTAGE	DATA PENDING
AMPERES	
DESIGN PRESSURE kPa (PSI)	
REFRIGERANT g (oz.)	
CLIMATIC CLASS	
INSULATION BLOWING GAS	
MINIMUM ROOM FLOOR AREA m ² (ft ²)	

Model Number	PT1A-FS-FS(-HS-HS) (-FGE-FGE)	PT2A-FS-FS(-HS-HS) (-FGE-FGE)
AC SUPPLY VOLTAGE	DATA PENDING	
AMPERES		
DESIGN PRESSURE kPa (PSI)		
REFRIGERANT g (oz.)		
CLIMATIC CLASS		
INSULATION BLOWING GAS		
MINIMUM ROOM FLOOR AREA m ² (ft ²)		

Model Number	RN1A-FS RT1A-FS-FS	RN2A-FS RT2A-FS-FS
AC SUPPLY VOLTAGE	DATA PENDING	
AMPERES		
DESIGN PRESSURE kPa (PSI)		
REFRIGERANT g (oz.)		
CLIMATIC CLASS		
INSULATION BLOWING GAS		
MINIMUM ROOM FLOOR AREA m ² (ft ²)		

Model Number	F1A-FGE(-HGE)(-FS)(-FSL)(-HS)(-HSL) PTF1A-HS-HS(-HGE-HGE)	F2A-FGE(-FGEN)(-HGE)(-FS)(-FSN)(-HS)
AC SUPPLY VOLTAGE	~115/60/1	~115/60/1
AMPERES	9	9.5
DESIGN PRESSURE kPa (PSI)	HI-2482 (360) LO-1310 (190)	HI-2482 (360) LO-1310 (190)
REFRIGERANT g (oz.)	R-290 115 (4.1)	R-290 107 (3.8)
CLIMATIC CLASS	5	5
INSULATION BLOWING GAS	HFO 1233zd(E)	HFO 1233zd(E)
MINIMUM ROOM FLOOR AREA m ² (ft ²)	5.5 (59.2)	5.1 (55.1)

Model Number	F3A-FS/HS
AC SUPPLY VOLTAGE	DATA PENDING
AMPERES	
DESIGN PRESSURE kPa (PSI)	
REFRIGERANT g (oz.)	
CLIMATIC CLASS	
INSULATION BLOWING GAS	
MINIMUM ROOM FLOOR AREA m ² (ft ²)	

Model Number	DT1A-HS	
	Refrigerator	Freezer
AC SUPPLY VOLTAGE	DATA PENDING	
AMPERES		
DESIGN PRESSURE kPa (PSI)		
REFRIGERANT g (oz.)		
CLIMATIC CLASS		
INSULATION BLOWING GAS		
MINIMUM ROOM FLOOR AREA m ² (ft ²)		

Model Number	DT2A-FS/HS	
	Refrigerator	Freezer
AC SUPPLY VOLTAGE	DATA PENDING	
AMPERES		
DESIGN PRESSURE kPa (PSI)		
REFRIGERANT g (oz.)		
CLIMATIC CLASS		
INSULATION BLOWING GAS		
MINIMUM ROOM FLOOR AREA m ² (ft ²)		



Note: Climatic Class 5: This appliance electrical safety tested for operation in maximum ambient temperature of 104°F (40°C) with 40% relative humidity. However, normal operating ambient temperature for refrigerator and solid door freezers must be within 45°F to 100°F (7°C to 38°C) and for glass door freezers 45°F to 80°F (7°C to 27°C). Operation of the appliance, for extended periods, outside of these normal temperature ranges may affect appliance performance.

II. Installation Instructions

A. Location

This appliance is approved for indoor use.

This appliance uses an A3 flammable refrigerant. For refrigerant charge and minimum room floor area, see the table below.

⚠ DANGER		
	R-290 Class A3 Flammable Refrigerant Used	
Model	R-290 Refrigerant Charge (kg)	Minimum Room Floor Area (operating or storage) Superficie Minimale du Local (service ou stockage) m ² (ft ²) - m ² (ft ²)
R1A-FGE(-FGECL)(-FGE CR)(-HGE)(-FS)(-FSJ)(-FSL)(-FSLJ)(-FSCL)(-FDCR)(-HS)(-HSL)		DATA PENDING
R2A-FGE(-HGE)(-FS)(-HS)(-FSN)(-FSC)		
R3A-FGE(-HGE)(-FS)(-FSCL)(-FSCR)(-HS)		
PT1A-FS-FS)(-HS-HS)(-FGE-FGE)		
PT2A-FS-FS)(-HS-HS)(-FGE-FGE)		
RN1A-FS, RT1A-FS-FS		
RN2A-FS, RT2A-FS-FS	145 (5.1)	6.9 (74.7)
F1A-FG(-FGE)(-HGE)(-FS)(-FSL)(-HS)(-HSL)	115 (4.1)	59.2 (5.5)
PTF1A-FS-FS(-HS-HS)(-FGE-FGE)		
F2A-FGE(-HGE)(-FS)(-HS)	107 (3.8)	5.4 (55.4)
F3A-FS(-HS)		
DT1A-HS - Refrigerator		
DT1A-HS- Freezer		
DT2A-FS(-HS) Refrigerator		
DT2A-FS(-HS) Freezer	115 (4.1)	6.2 (67)
		
<p>≥ Area m² (ft²) (see "Minimum Room Floor Area" above)</p> <p>≥ Superficie m² (pi²) (voir « Superficie Minimale du Local » ci-dessus)</p>		

⚠ DANGER continued

R-290 Refrigerant Charge:

- If greater than 114 g (4 oz.), do not install in public corridor or lobby.
- If greater than 152 g (5.3 oz.), do not install within 6 m (20 ft) of open flame.

Charge de réfrigérant R-290:

- Si elle est supérieure à 114 g (4 oz.), ne pas l'installer dans un couloir public ou un hall d'entrée.
- Si elle est supérieure à 152 g (5.3 oz.), ne pas l'installer à moins de 6 m (20 pi) d'une flamme nue.

This appliance is not intended for use above 2,000 m (6,561 ft). Installation above 2,000 m (6,561 ft) may adversely affect safety, performance, and component life.

⚠ WARNING

- The appliance must be installed in accordance with applicable national, state, and local regulations.
- Appliance is heavy. Use care when lifting or positioning. Work in pairs when needed to prevent injury or damage. Do not lift using the top section or the drawers.
- Do not tilt the appliance more than 45°.
- The appliance is not intended for outdoor use.
- This appliance to be installed in accordance with the Safety Standard for Refrigeration Systems ANSI/ASHRAE 15
- Normal operating ambient temperature for refrigerator and solid door freezers must be within 45°F to 100°F (7°C to 38°C) and for glass door freezers 45°F to 80°F (7°C to 27°C). Operation of the appliance, for extended periods, outside of this normal temperature range may affect appliance performance.

- The appliance must not be located next to ovens, grills, or other high heat producing equipment.
- The location must provide a firm and level foundation for the appliance.
- The appliance must not be located in a corrosive environment.
- Minimum Clearance

Models	Side	Top	Rear
Reach-In Refrigerators and Freezers (Except Roll-In's, Roll-Thru's, Pass-Thru's, and 2-Section Freezers)	0" (0 cm)	0" (0 cm)	3" (8 cm)
Reach-In Refrigerators Roll-In's	0" (0 cm)	10" (25 cm)	0" (0 cm)
Reach-In Refrigerators Roll-Thru's and Pass-Thru's	0" (0 cm)	0" (0 cm)	N/A
2-Section Freezers	0" (0 cm)	10" (25 cm)	3" (8 cm)

B. Checks Before Installation

⚠ WARNING

Refer to the nameplate for electrical specifications. The nameplate is located on the right side wall of the 1 and 2 section cabinet interior and the rear wall of the 3 section cabinet interior. For more electrical connection details, see "I.G. Electrical Connection." We reserve the right to make specification and design changes without prior notice.

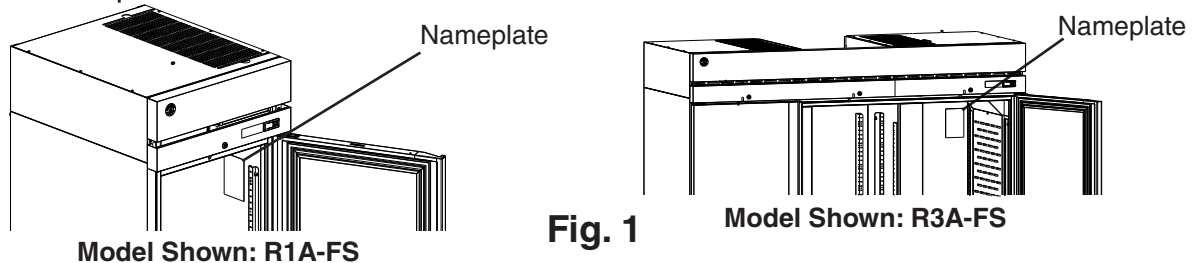

- Visually inspect the exterior of the shipping package and immediately report any damage to the carrier. Upon opening the package, any concealed damage should also be immediately reported to the carrier.
- Remove the shipping carton, tape, and packing material. Remove the protective plastic film from the exterior panels on all models and from the interior door panels on solid door models. If the appliance is exposed to the sun or to heat, remove the film after the appliance cools.
- Remove all accessory containers before discarding the packing materials. Dispose of all packing materials in a proper and environmentally responsible manner.
- Check for missing or damaged accessories.

C. Setup

1. Caster or Optional 6 in. Leg Installation and Leveling the Appliance

a) Caster or Optional 6 in. Leg Installation

- 1) Move as close to the final location as possible.
- 2) Remove the 2 bolts securing the appliance to the pallet, then remove the appliance from the pallet. Block the appliance securely at a height of 8" (20 cm) off the floor. Do not lay the appliance down. **NOTICE! Do not allow the door(s) to bear the weight of the appliance.**
- a) Casters: Attach and tighten the casters to the bottom of the appliance. Locking casters should be attached to the front of the appliance for standard models and on the service (control module) side on pass-thru models. See Fig. 2.

NOTICE! Ensure casters are completely threaded into appliance and tight.

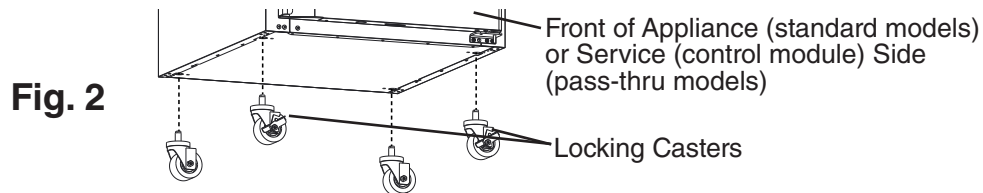

- b) Legs: Optional 6 in. legs available. Attach and tighten the optional adjustable 6 in. legs to the bottom of the appliance.

⚠ WARNING

When using legs, avoid sliding the appliance across the floor after legs are installed.

b) Leveling the Appliance

After installing the casters or optional 6 in. legs, lower the appliance to the floor and check the level of the appliance.

- a) Casters: If the appliance is out of level, follow the instructions and steps found in HS-3590 provided in the accessories bag. Otherwise, continue to the next section. **NOTICE! Make sure the casters are tight and no slack is left between the casters, shim plates, and appliance.**
- b) Legs: If the appliance is out of level, turn the bottom portion of the leg for height adjustment. Otherwise, continue to the next section. **NOTICE! Make sure the legs are tight and no slack is left between the leg and appliance.**

2. Install the Shelves

Shelf support clips are provided in the accessory pack.

- 1) Place the shelf support clips into the pilasters (4 shelf support clips per shelf). Indexing holes are provided on the pilasters in evenly spaced intervals to assist in positioning the support clips at the same height. See Fig. 3.
- 2) Place the shelves in position on the shelf support clips.

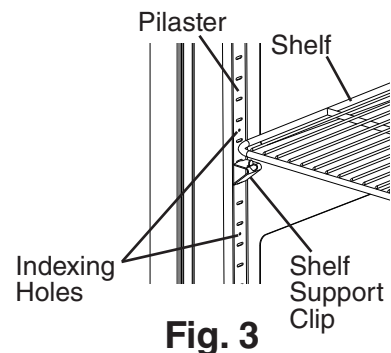

3. Check the Refrigeration Circuit

- 1) Visually check that the refrigerant lines do not rub or touch other lines or surfaces and that the condenser fan blade turns freely.
- 2) Check that the compressor is snug on all mounting pads.

D. DT1A-HS Heated Condensate Pan Installation

⚠ WARNING

Failure to install the heated condensate pan in accordance with this manual could adversely affect safety and result in costly water damage.

- 1) Remove the heated condensate pan and heated condensate pan bracket from the accessory bag.
- 2) Place the heated condensate pan in the heated condensate pan bracket, then using the 4 screws provided in the accessory bag, secure the heated condensate pan bracket to the rear of the appliance. See Fig. 4.

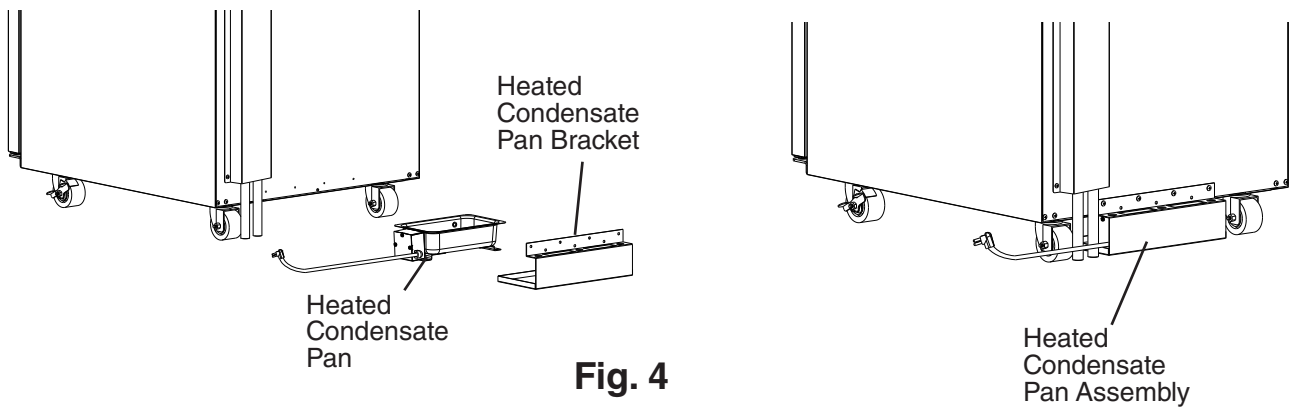

Fig. 4

- 3) Remove the channel cover from the back of the appliance. See Fig. 5.
- 4) Remove the heated condensate pan receptacle cover from the heated condensate pan receptacle. Next, plug the heated condensate pan plug into the heated condensate pan receptacle. See Fig. 6.

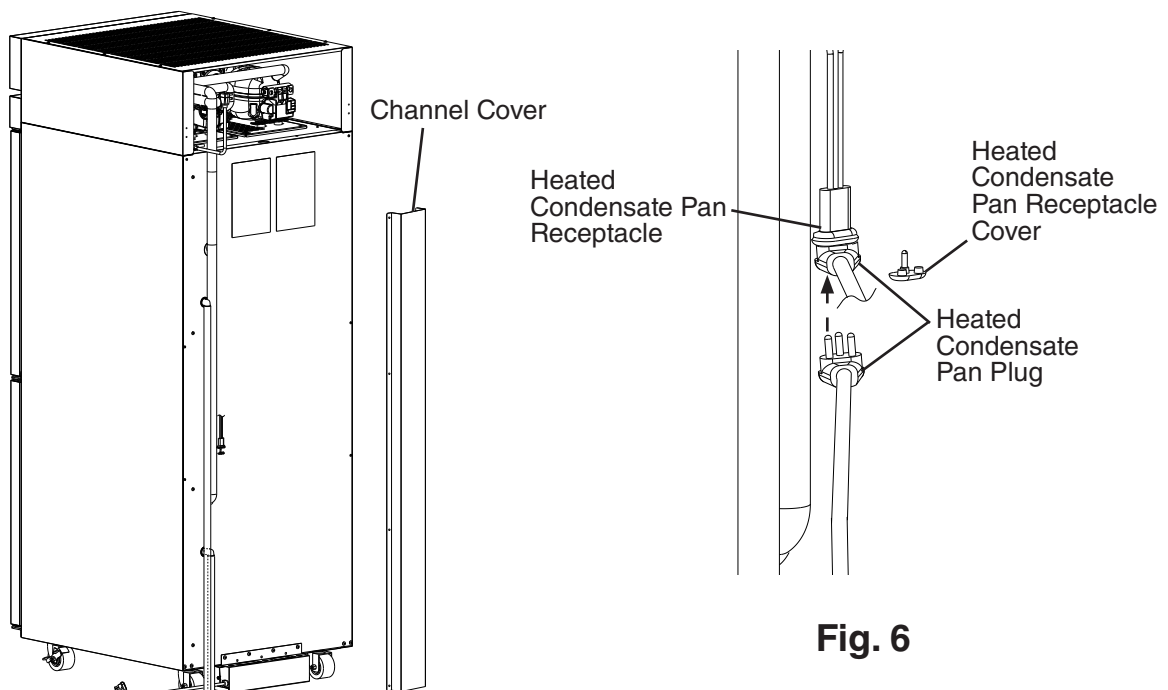

Fig. 5

Fig. 6

- 5) Replace the channel cover in its correct position.
- 6) Route the drain hoses into the heated condensate pan assembly. See Fig. 7.
Warning! Confirm that the drain hoses do not contact the heater. Adjust as necessary.
- 7) Using a nylon tie from the accessory bag, secure the heated condensate pan power supply cord to one of the drain hoses. See Fig. 8.
- 8) Place the appliance in its final location.

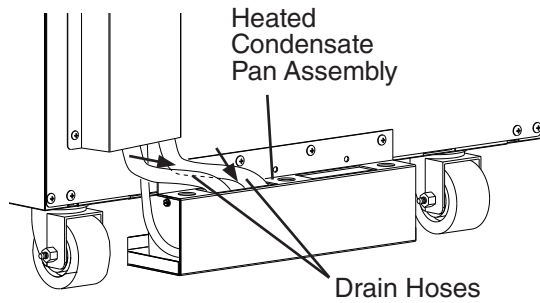

Fig. 7

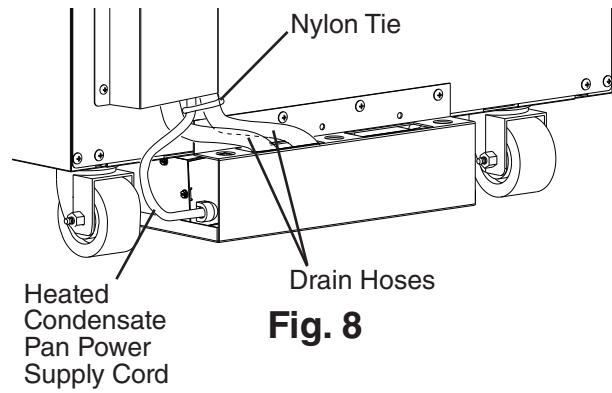

Fig. 8

E. Food Cart Ramp (Roll-In/Roll-Thru Appliances)

Confirm the area where the appliance is to be installed is flat and level.

- 1) Place the appliance in position, then seal the perimeter where the appliance contacts the floor with approved caulk compound in a smooth and easily cleanable manner.

See Fig. 9.

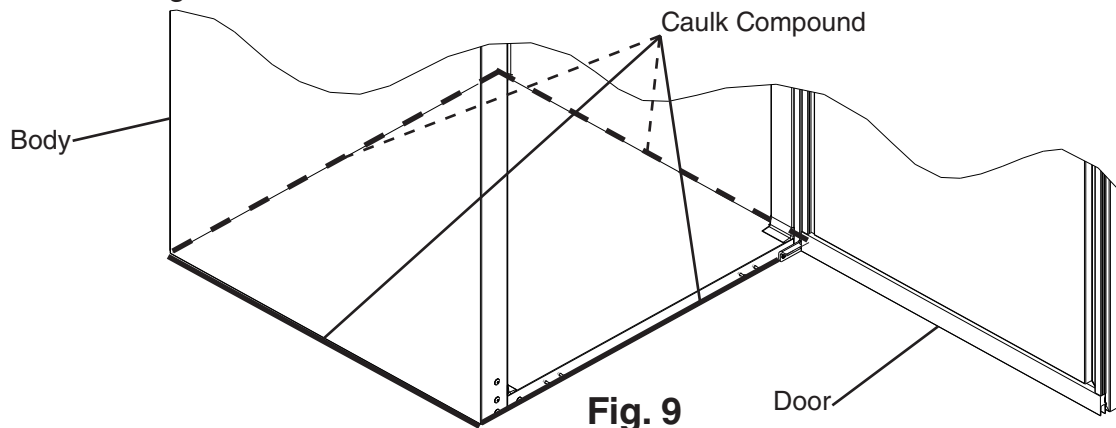

Fig. 9

- 2) Remove the 2 filler screws from the bottom of the appliance. See Fig. 10. Next, loosen the 4 truss head screws at the bottom of the appliance 3 to 4 mm (1/8"), then lay the ramp onto the loosened truss head screws. See Fig. 10.

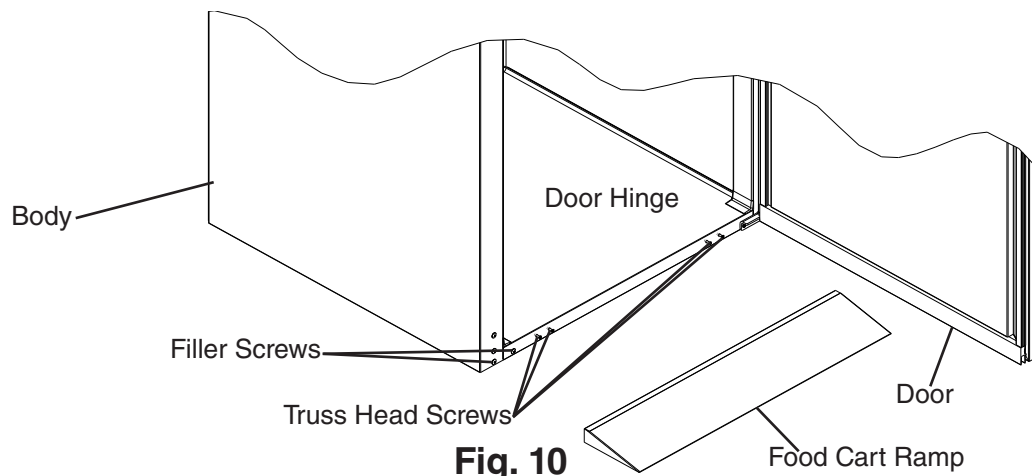

Fig. 10

- 3) Seal around the ramp as shown in Fig. 11 with an approved caulk compound.

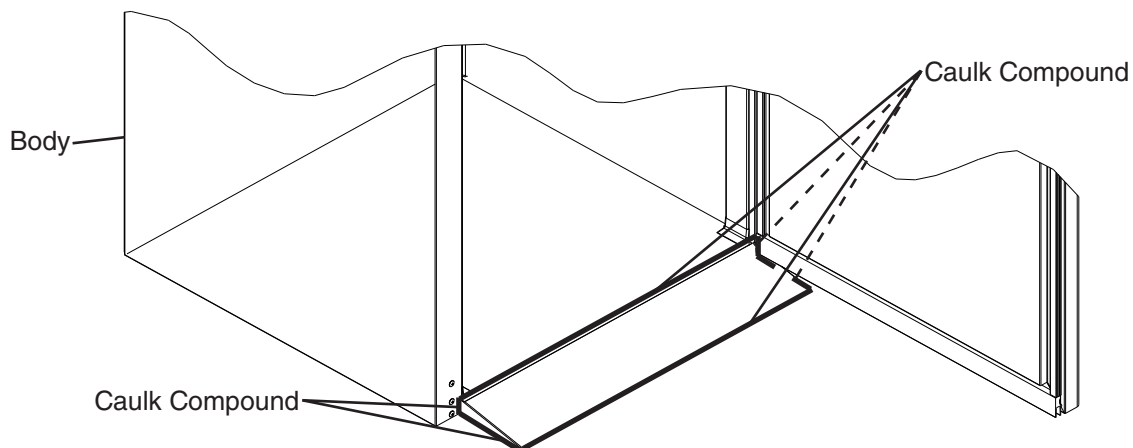

Fig. 11

4) Loosen the door sweep bracket adjustment screws. See Fig. 12.

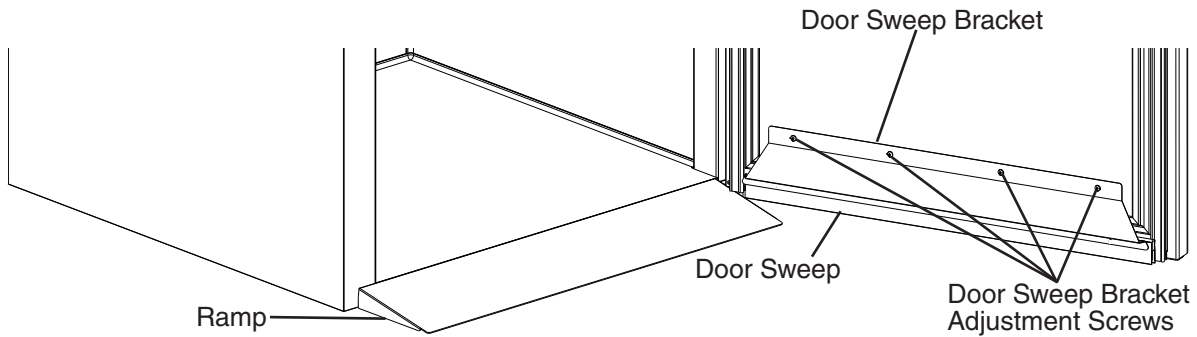

Fig. 12

5) Adjust the door sweep so that the door sweep touches the ramp when the door is closed. See Fig. 13. Once in its correct position, tighten the door sweep bracket adjustment screws.

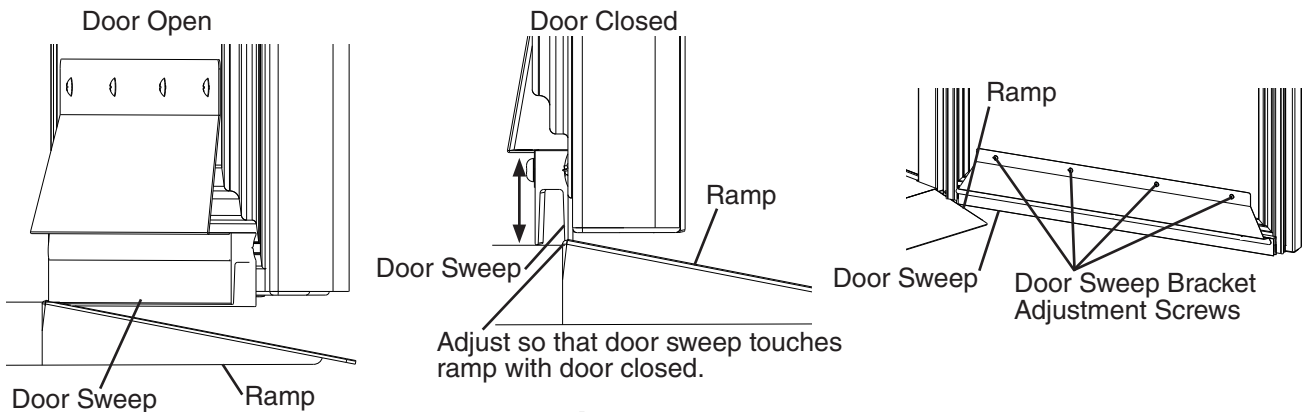

Fig. 13

6) Drill three 1/8" pilot holes in the positions shown in Fig. 14. Use the 3 screws provided in the accessory bag to secure the door sweep to the door sweep bracket and the door.

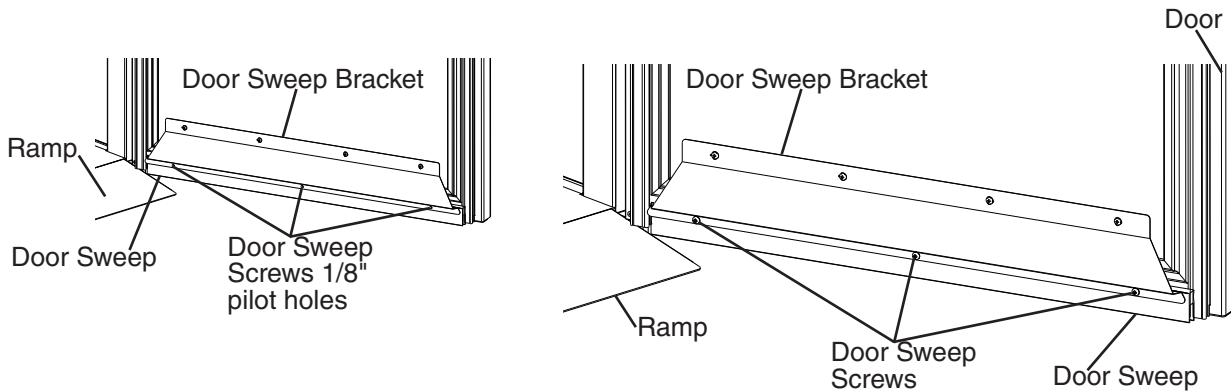

Fig. 14

F. Door Reversal

This appliance is provided with a cabinet design which, after being delivered to the installation location, permits changing of the door swing from left to right or right to left.

⚠ WARNING

- Wear proper PPE (personal protection equipment) when executing these procedures (safety glasses and gloves).
- Keep fingers away from edge of upper hinge bracket. Spring cartridge can cause the upper hinge bracket to move suddenly with extreme force.

1. Full Solid Door and Full FGE Glass Door Reversal

Note: Hinge brackets, and spring cartridge are universal and can be used in both left and right-hinged applications.

Example shows change from right hinged to left hinged.

- 1) Lock the front casters.
- 2) Remove the front panel, then being careful not to pull the wires on the control module and door switch(es), remove the control panel. Secure the control panel so that it does not interfere with the hinge bracket and will not fall. See Fig. 15.

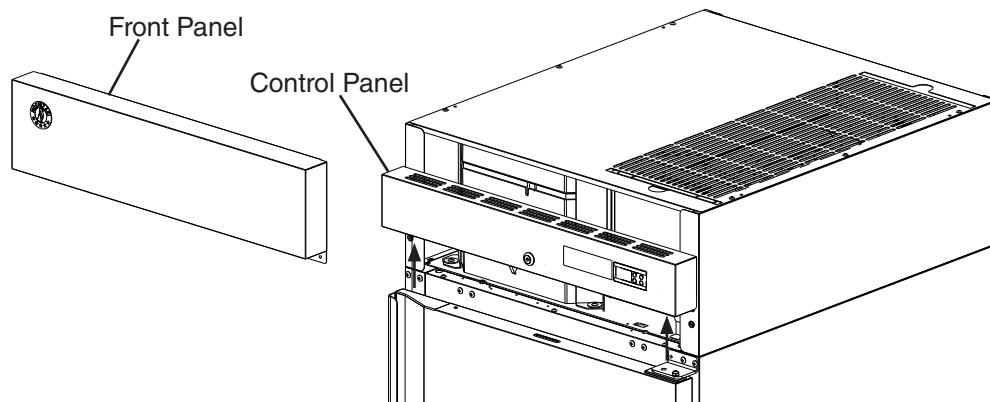

Fig. 15

- 3) While maintaining a hold on the door, remove the upper hinge bracket then lift the door up off the bottom hinge and set aside. See Fig. 16. Remove the filler screws from the opposite side upper hinge bracket holes and mount them into the holes of the removed upper hinge bracket. **NOTICE! Be sure to reuse the bracket screws for mounting the bracket as the bracket screws are 5x12 and filler screws are 5x10.**

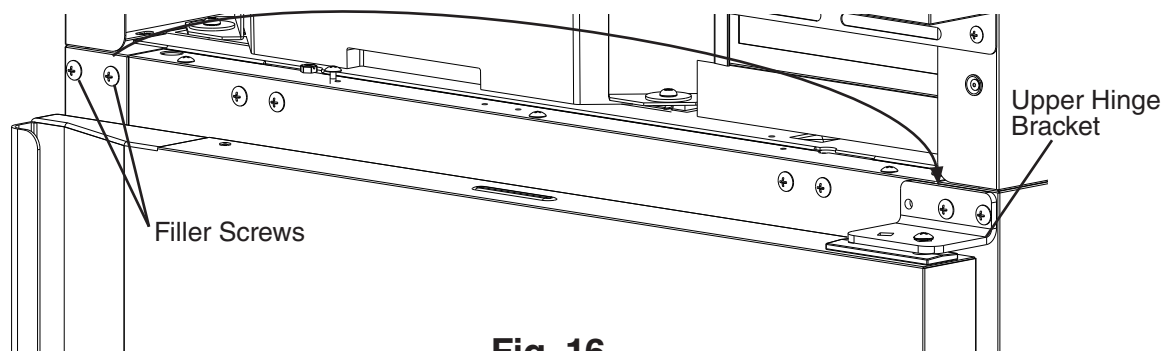
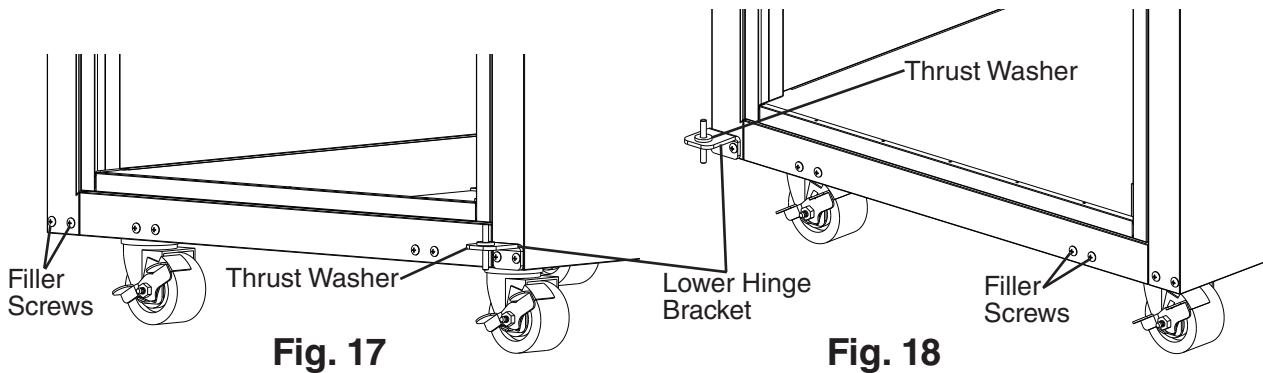
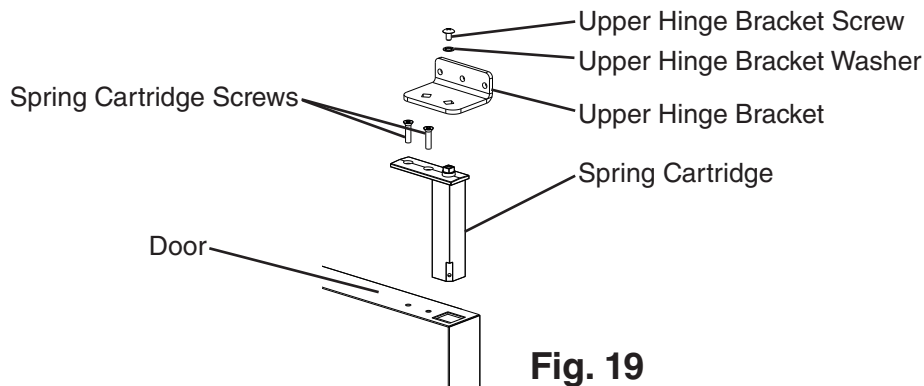

Fig. 16

- 4) Remove the lower hinge bracket and thrust washer. See Fig. 17. Retain thrust washer for opposite side lower hinge bracket installation. Remove the filler screws from the opposite side lower hinge bracket holes and mount them into the holes of the removed lower hinge bracket. **NOTICE! Be sure to reuse the bracket screws for mounting the bracket as the bracket screws are 5x12 and filler screws are 5x10.**
- 5) Secure the lower hinge bracket to the opposite side lower hinge bracket location, then place the thrust-washer on the lower hinge bracket. See Fig. 18.



- 6) Remove the screw and washer securing the upper hinge bracket to the spring cartridge. Remove the 2 screws securing the spring cartridge to the door, then remove the spring cartridge from the door. See Fig. 19.



- 7) Rotate the door 180 degrees, to its new orientation. Remove the nylon bearing and filler screws. See Fig. 20. **NOTICE! Care should be taken not to damage the door.** Mount the nylon bearing and filler screws into the holes left by the spring cartridge in the lower section of the door. See Fig. 21.

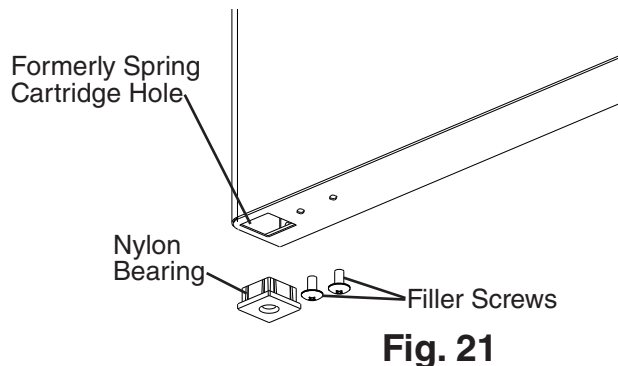
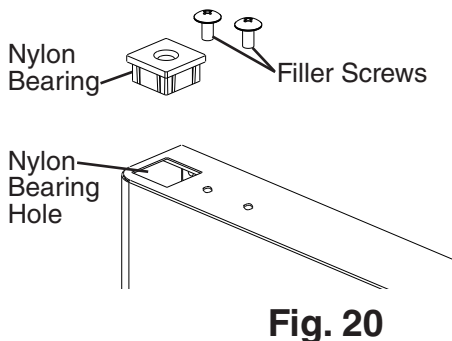

8) Clear foam from the spring cartridge hole to allow for spring cartridge installation. Install the spring cartridge and secure it to the door using the spring cartridge screws removed in step 6. See Fig. 22. Next, align the upper hinge bracket to the door in the orientation that allows for closed door installation. See Fig. 23. Secure the upper hinge bracket to the door using the screw and washer removed in step 6.

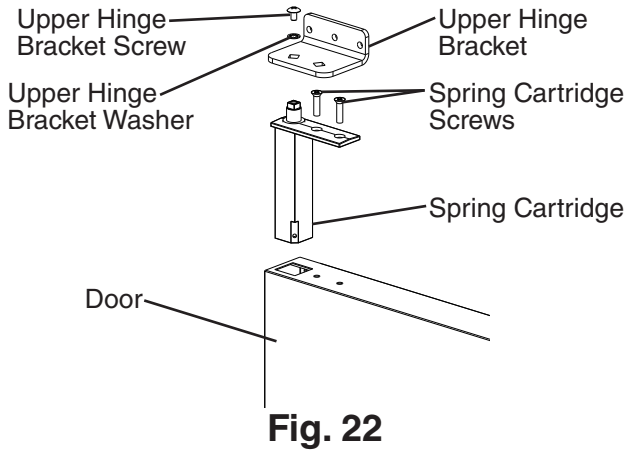

Fig. 22

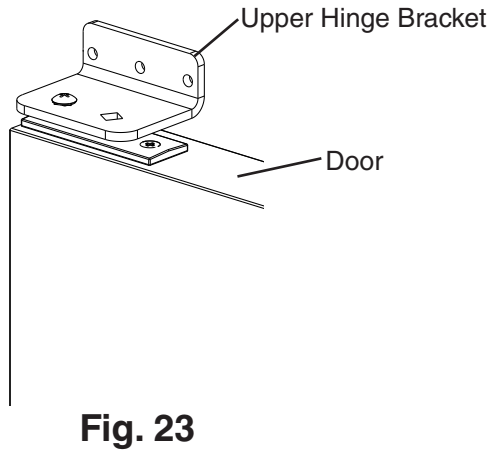

Fig. 23

9) Make sure the thrust washer is in place, then mount the door onto the lower hinge bracket (nylon bearing over lower hinge bracket pin). See Fig. 24.

10) Secure the upper hinge bracket to the appliance. See Fig. 25.

11) Verify swing. Move the control panel hole plugs to the other side, then replace and secure the control panel and front panel in their correct positions. Verify the door switch and lock function.

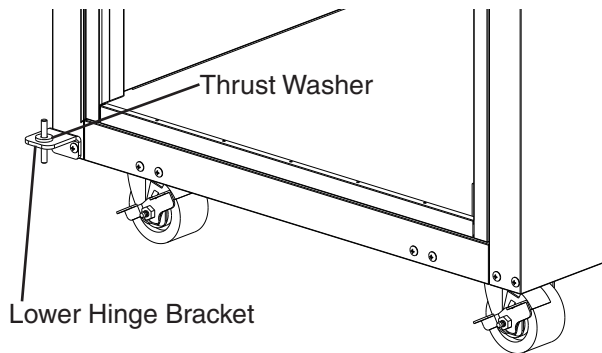

Fig. 24

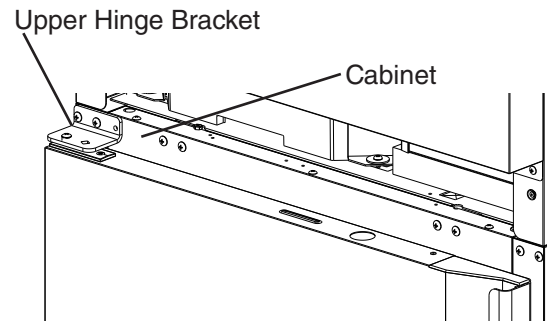

Fig. 25

2. Half Solid Door and Half HGE Glass Door Reversal

Note: Hinge brackets, and spring cartridge are universal and can be used in both left and right-hinged applications.

Example shows change from right hinged to left hinged.

- 1) Lock the casters.
- 2) Remove the front panel, then being careful not to pull the wires on the control module and door switch(es), remove the control panel. Secure the control panel so that it does not interfere with the hinge bracket and will not fall. See Fig. 26.

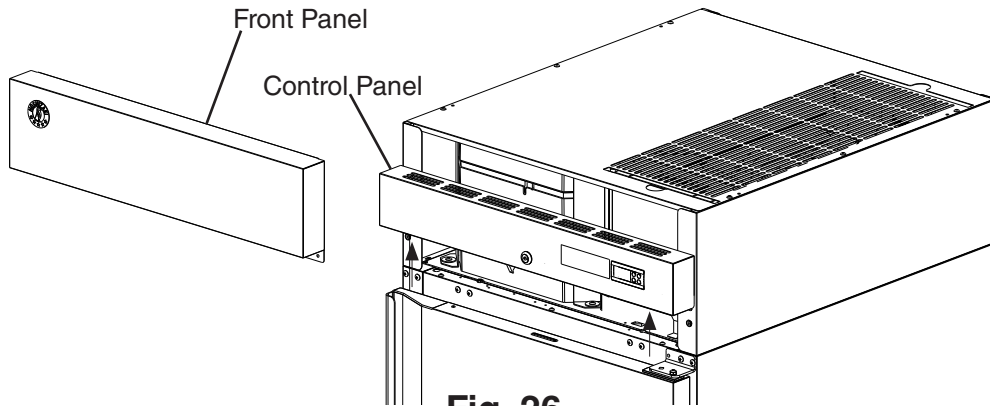

Fig. 26

- 3) While maintaining a hold on the upper door, remove the upper hinge bracket then lift the door off the center hinge bracket. See Fig. 27. Retain the upper center hinge bracket thrust-washer for opposite side hinge bracket installation.

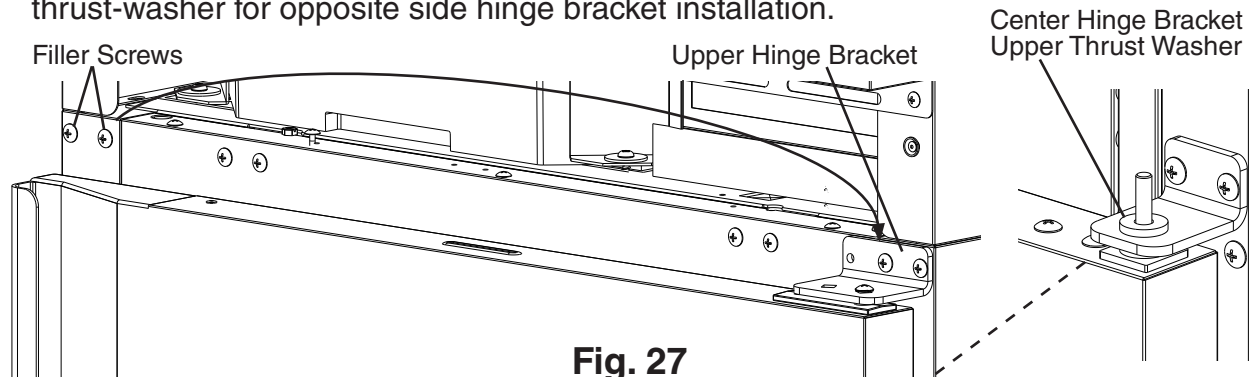

Fig. 27

- 4) Rotate the upper hinge bracket 180 degrees counter clockwise. See Fig. 28. Next, remove the spring cartridge screw and washer, then remove the upper hinge bracket and thrust washers (2). Set the door aside. Retain the upper hinge bracket thrust washers for opposite side hinge bracket installation.

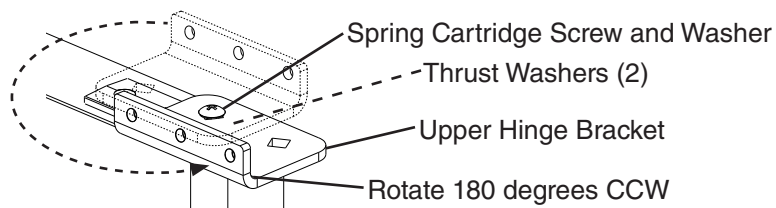

Fig. 28

- 5) Remove the filler screws from the opposite side upper hinge bracket holes and mount them into the holes of the removed upper hinge bracket. **NOTICE! Be sure to reuse the hinge bracket screws for mounting the hinge bracket as the hinge bracket screws are 5×12 and filler screws are 5×10.**
- 6) While maintaining a hold on the lower door, remove the lower hinge bracket from the cabinet, then lower the door off the center hinge bracket and set aside. See Fig. 29. Retain the center hinge thrust washers for opposite side installation.
- 7) Remove the center hinge bracket from the cabinet. Remove the filler screws from the opposite side lower and center hinge bracket holes and mount them into the holes of the removed lower and center hinge brackets. **NOTICE! Be sure to reuse the hinge bracket screws for mounting the hinge brackets as the hinge bracket screws are 5×12 and filler screws are 5×10.**

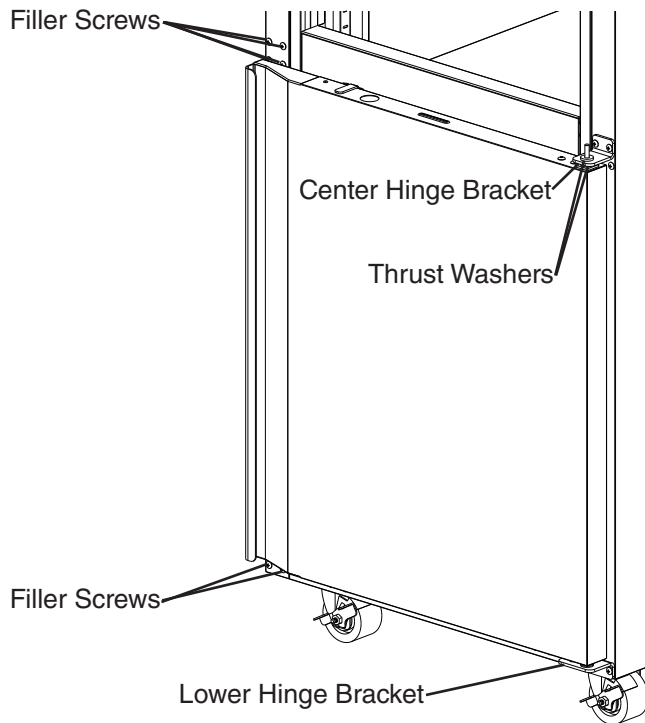

Fig. 29

- 8) Remove the door latch from the lower door. See Fig. 30.

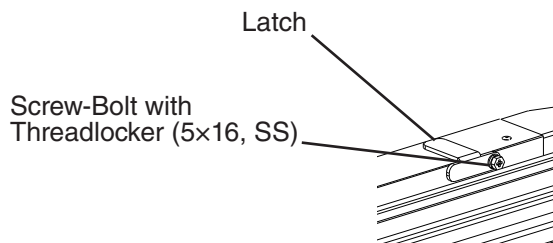

Fig. 30

- 9) Remove the lower hinge bracket spring cartridge screw, washer, and thrust washers from the door. Set the door aside. Next, secure the lower hinge bracket to the opposite side. Make sure the lower thrust-washers are in place. See Fig. 31.

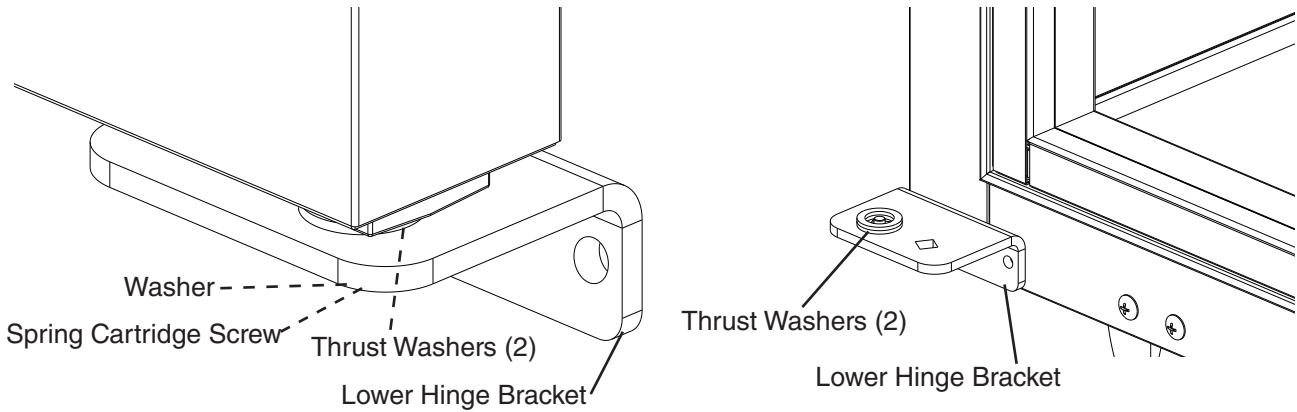

Fig. 31

- 10) Rotate the former upper door 180 degrees to its new lower door orientation.
NOTICE! Care should be taken not to damage the door.
- 11) Attach the lower door latch to the newly rotated lower door (former upper door).
 See Fig. 32.

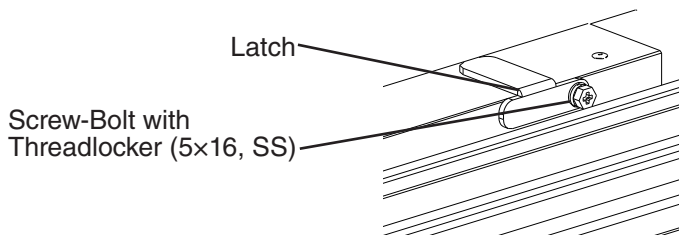

Fig. 32

- 12) Make sure the lower hinge bracket thrust washers (2) are in place, then with the lower door (rotated upper door) in the maximum open position, place the door onto the lower hinge bracket. See Fig. 33.
 The spring cartridge shaft should slide into the lower hinge bracket and be flush with the bottom of the lower hinge bracket.

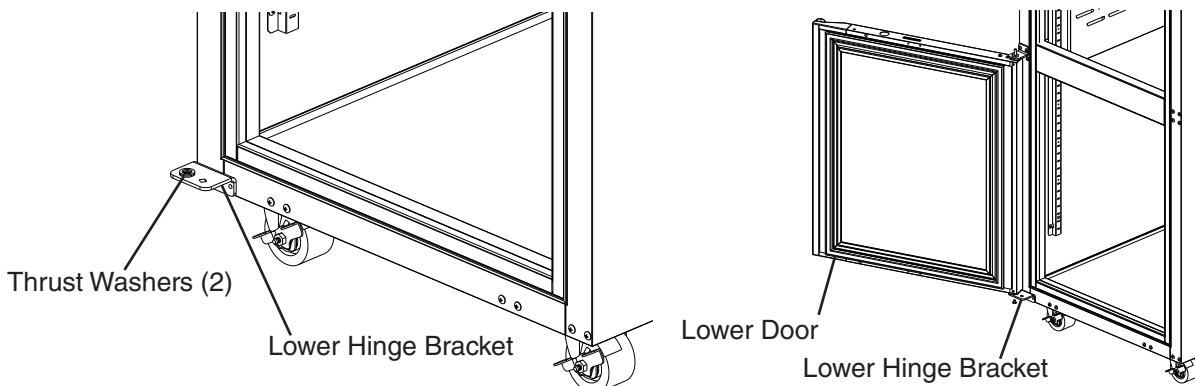

Fig. 33

- 13) Place the center hinge bracket lower pin with thrust washer into the nylon bearing on top of the door. Secure the center hinge bracket to the cabinet. See Fig. 34.

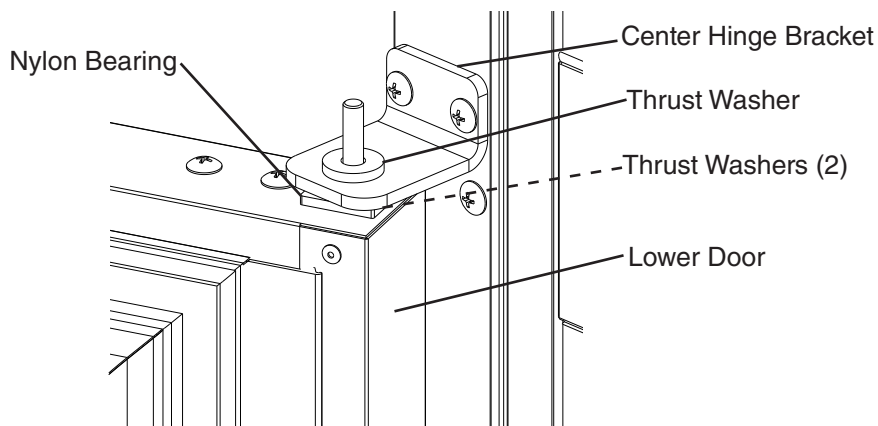

Fig. 34

- 14) Secure the door to the lower hinge bracket using the spring cartridge screw and washer. Note: Be sure thrust washers (2) are in place between lower hinge bracket and door. See Fig 35.
- 15) Verify swing. Open the door and test the opening and closing tension. Adjust as needed until the door opens and closes correctly.

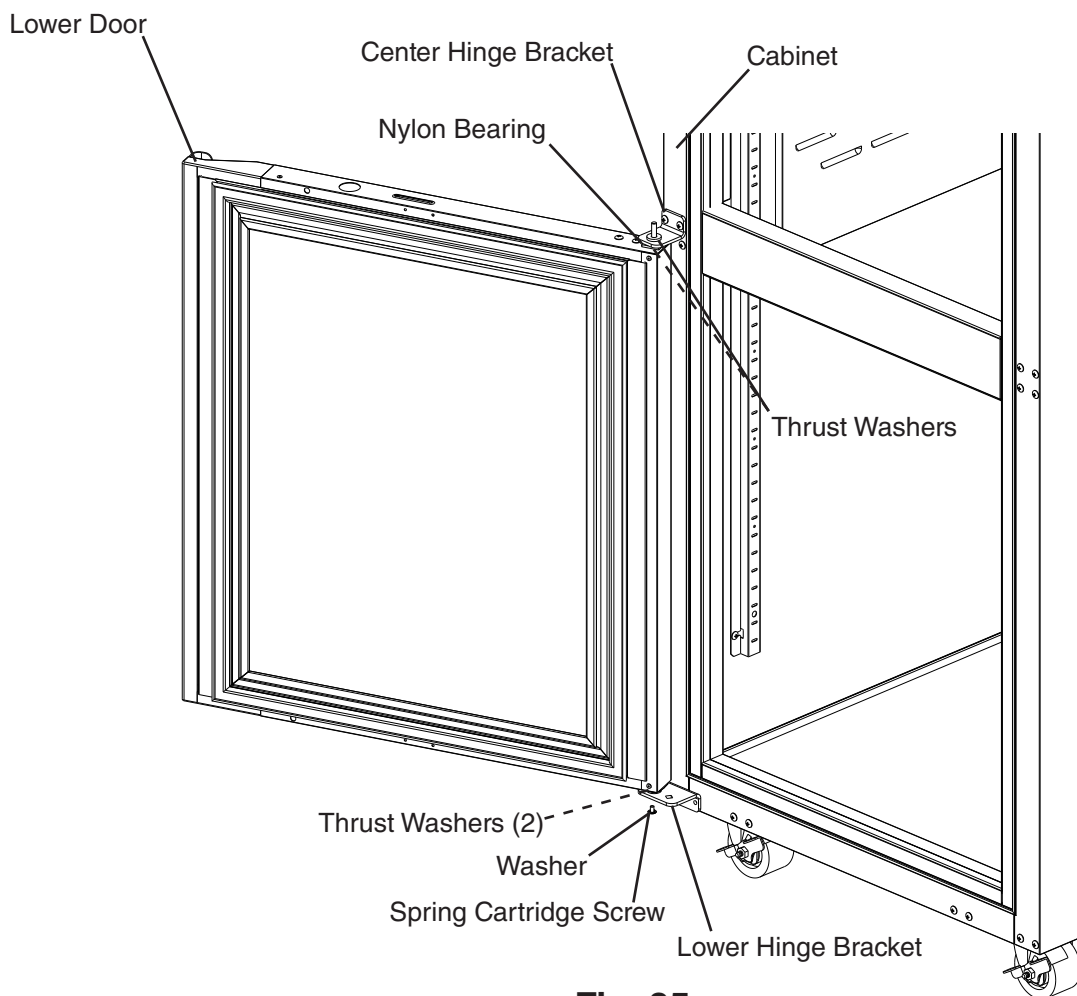

Fig. 35

- 16) Make sure the center hinge bracket upper thrust washer is in place on top of the center hinge bracket upper pin.
- 17) Align the upper hinge bracket to the upper door in the orientation that allows for closed door installation. Make sure the thrust washers are in place between the upper hinge bracket and upper door, then secure the upper hinge bracket to the door using the spring cartridge screw and washer removed earlier. The spring cartridge shaft should slide into the upper hinge bracket and be flush with the top of the doors upper hinge bracket.
- 18) With the door in the closed position, place the upper doors nylon bearing onto the center hinge bracket upper pin, then secure the upper hinge bracket to the cabinet with the upper door in the closed position. See Fig. 36.
- 19) Verify swing. Move the control panel hole plugs to the other side, then replace and secure the control panel and front panel in their correct positions. Verify light switch and lock function and adjust as necessary.

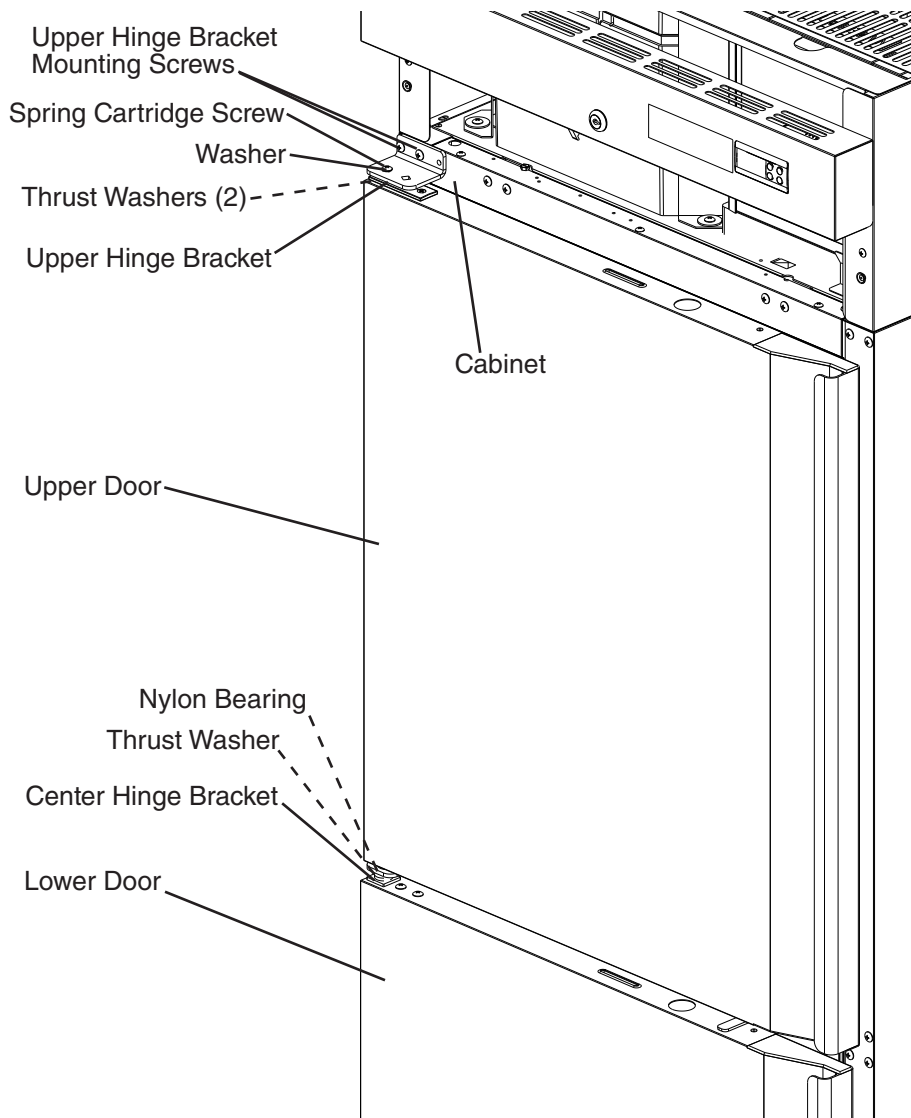



Fig. 36

G. Electrical Connection

WARNING

- Electrical connection must meet national, state, and local electrical code requirements. Failure to meet these code requirements could result in death, electric shock, serious injury, fire, or severe damage to equipment.
 - This appliance requires an independent power supply of proper capacity. See the nameplate for electrical specifications. Failure to use an independent power supply of proper capacity can result in a tripped breaker, blown fuse, damage to existing wiring, or component failure. This could lead to heat generation or fire.
 - **115VAC Models: THIS APPLIANCE MUST BE GROUNDED:** This appliance is equipped with a NEMA 5-15 three-prong grounding plug  to reduce the risk of potential shock hazards. It must be plugged into a properly grounded, independent 3-prong wall outlet. If the outlet is a 2-prong outlet, it is your personal responsibility to have a qualified electrician replace it with a properly grounded, independent 3-prong wall outlet. Do not remove the ground prong from the plug and do not use an adapter plug. Failure to follow these instructions may result in death, electric shock, or fire.
 - **208/230VAC Models: THIS APPLIANCE MUST BE GROUNDED:** This appliance is equipped with a NEMA L14-20 four-prong locking, grounding plug  to reduce the risk of potential shock hazards. It must be plugged into a properly grounded, independent 4-prong wall outlet. If the outlet is a 3-prong outlet or a 4-prong non-locking outlet, it is your personal responsibility to have a qualified electrician replace it with a properly grounded, independent 4-prong locking wall outlet. Do not remove the ground prong from the plug and do not use an adapter plug. After plugging in, twist the plug clockwise to lock it into place. Failure to follow these instructions may result in death, electric shock, or fire.
 - To reduce the risk of electric shock, do not touch the plug with damp hands.
 - Press and hold the control module "U" button to turn "OFF" before unplugging the appliance to reduce the risk of electric shock.
 - Do not use an extension cord.
 - Do not use an appliance with a damaged power cord. The power cord should not be altered, jerked, bundled, weighed down, pinched, or tangled. Such actions could result in electric shock or fire. To unplug the appliance, be sure to pull the plug, not the cord, and do not jerk the cord.
 - If the supply cord is damaged, it must be replaced by the manufacturer, its service agent, or similarly qualified persons in order to avoid a hazard. Upon replacement, the GREEN ground wire in the power cord must be connected to the designated grounding screw.
- Usually an electrical permit and services of a licensed electrician are required.
 - The maximum allowable voltage variation is ± 6 percent of the nameplate rating.

H. Final Checklist

- 1) Is the appliance level?
- 2) Have the front casters been locked?
- 3) Is the appliance in a site where the ambient temperature is as specified below all year around?
 - Refrigerators and Solid Door Freezers 45°F to 100°F (7°C to 38°C)
 - Glass Door Freezers 45°F to 80°F (7°C to 27°C)

- 4) Have the minimum clearance requirements specified below been met?

Models	Side	Top	Rear
Reach-In Refrigerators and Freezers (Except Roll-In's, Roll-Thru's, Pass-Thru's, and 2-Section Freezers)	0" (0 cm)	0" (0 cm)	3" (8 cm)
Reach-In Refrigerators Roll-In's	0" (0 cm)	10" (25 cm)	0" (0 cm)
Reach-In Refrigerators Roll-Thru's and Pass-Thru's	0" (0 cm)	0" (0 cm)	N/A
2-Section Freezers	0" (0 cm)	10" (25 cm)	3" (8 cm)

- 5) Have the shipping carton, tape, and packing material been removed from the appliance? Has the protective plastic film been removed from the exterior panels on all models and from the interior door panels on solid door models?
- 6) Have the appliance and accessories been checked for shipping damage?
- 7) Has the power supply voltage been checked or tested against the nameplate rating? Is the power supply a properly grounded, independent wall outlet? Does the electrical connection meet all national, state, and local code and regulation requirements.
- 8) Have the refrigerant lines been checked to make sure they do not rub or touch other lines or surfaces? Has the condenser fan blade been checked to make sure it turns freely? Is the compressor securely attached?
- 9) Have the shelves been properly installed?
- 10) Has the end user been given the instruction manual, and instructed on how to operate the appliance and the importance of the recommended periodic maintenance?
- 11) Has the end user been given the name and telephone number of an authorized service agent?
- 12) Has the warranty card been filled out and forwarded to the factory for warranty registration?

III. Operating Instructions



R-290 Class A3 Flammable Refrigerant Used

⚠ DANGER

Risk of Fire or Explosion. Flammable Refrigerant Used.

- Be sure to follow all Important Safety Information located at the beginning of this manual.
- Failure to install, operate, and maintain the appliance in accordance with this manual will adversely affect safety, performance, component life, and warranty coverage.
- Keep clear of obstruction all ventilation openings in the appliance enclosure or in the structure for building-in.

Risque D'Incendie ou D'Explosion. Fluide Frigorigène Inflammable Utilisé.

- Veuillez à respecter toutes les consignes de sécurité importantes figurant au début de ce manuel.
- Le fait de ne pas installer, utiliser et entretenir l'appareil conformément à ce manuel aura des conséquences négatives sur la sécurité, les performances, la durée de vie des composants et la couverture de la garantie.
- Ne pas obstruer les ouvertures de ventilation dans l'enceinte de l'appareil ou dans la structure d'encastrement.

A. Important Notes About Usage

⚠ WARNING

- Failure to install, operate, and maintain the appliance in accordance with this manual may adversely affect safety, performance, component life, and warranty coverage.
- Only qualified service technicians should install and service the appliance.
- To reduce the risk of electric shock, do not touch the plug with damp hands.
- Care should be used when placing items on top of the appliance. Do not store liquid containers or items that could fall through the louvers on top of the appliance. This could cause electric shock or fire.
- Do not use combustible spray or place volatile or flammable substances in or near the appliance. They might catch fire.
- Do not splash, pour, or spray water directly onto or into the appliance. This might cause short circuit, electric shock, corrosion, or failure.
- Food storage and handling must comply with applicable codes and regulations.
- Keep the area around the appliance clean. Dirt, dust, or insects in the appliance could cause harm to individuals or damage to the equipment.
- The appliance is designed only for temporary storage of food. Employ sanitary methods. Use for any other purposes (for example, storage of chemicals or medical supplies such as vaccine and serum) could cause deterioration of stored items.

⚠ WARNING continued

- Do not store items near air outlets. Otherwise, items may freeze up and crack or break causing a risk of injury or contamination of other food.
- Do not put warm or hot foods in the cabinet. Let them cool first, or they will raise the cabinet temperature and could deteriorate other foods in the cabinet or overload the appliance.
- All foods should be wrapped in plastic film or stored in sealed containers. Otherwise, foods may dry up, pass their smells onto other foods, cause frost to develop, result in poor appliance performance, or increase the likelihood of cross-contamination.
Certain dressings and food ingredients, if not stored in sealed containers, may accelerate corrosion of the evaporator, resulting in failure.
- Do not block air inlets or outlets, otherwise, cooling performance may be reduced.
- Do not tightly pack the cabinet. Allow some space between items to ensure good air flow. Also allow space between items and interior surfaces.
- Do not place any product on the floor of the cabinet. All product must be placed on properly installed shelves.
- Do not throw anything onto the shelves or load any single shelf with more than 120 lb. (54.5 kg) of product. They might fall off and cause injury.
- Do not place more than 20 lb. (9 kg) on the top panel. Items must be stable and secure to prevent items from falling off of the appliance.
- Open and close the doors with care. Opening the doors too quickly or forcefully may cause injury or damage to the appliance or surrounding equipment.
- Be careful not to pinch fingers when opening and closing the doors. Be careful when opening and closing the doors when children are in the area.
- The appliance is not intended for use by persons (including children) with reduced physical, sensory, or mental capabilities, or lack of experience and knowledge, unless they have been given supervision or instruction concerning use of the appliance by a person responsible for their safety.
- Children should be properly supervised around the appliance.
- Do not climb, stand, or hang on the appliance or doors or allow children or animals to do so. Do not climb into the appliance or allow children or animals to do so. Death or serious injury could occur or the appliance could be damaged.

NOTICE

- Protect the floor when moving the appliance to prevent damage to the floor.
- Keep ventilation openings, in the appliance enclosure or in the built-in structure, clear of obstruction. Blockage of airflow could negatively affect performance and damage the appliance.
- Do not allow the appliance to bear any outside weight.
- To prevent deformation or cracks, do not spray insecticide onto the plastic parts or let them come into contact with oil.
- To avoid damage to the gasket, use only the door handle when opening and closing.
- Do not leave the doors open.

B. Startup

⚠ WARNING

- All parts are factory-adjusted. Improper adjustments may adversely affect safety, performance, component life, and warranty coverage.
- To reduce the risk of electric shock, do not touch the plug with damp hands.

IMPORTANT

At startup, there is a slight delay before the compressor starts.

- 1) Plug the appliance into the electrical outlet. At startup, there is a slight delay before the compressor starts. **IMPORTANT! Perimeter heater (freezer models only), mullion heater (except 1-section refrigerator models), and drain tube heater (freezer models only), energize once appliance is plugged into the electrical outlet and remain energized even while the control module is in "OFF" mode. Appliance must be unplugged from the electrical outlet to de-energize the heaters.**
- 2) Allow the appliance to cool down prior to loading it with food products.

C. Controls and Adjustments

1. Temperature Display

The cabinet temperature is displayed on the control module. See Fig. 37. The display default is in °F.

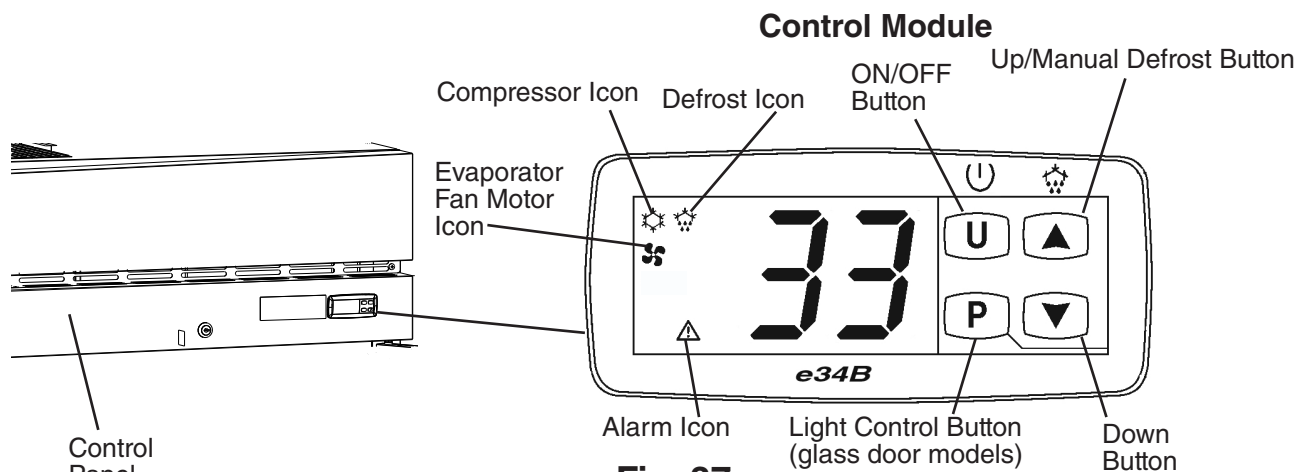

2. Adjusting the Temperature Setpoint

The temperature setpoint is the value for the average cabinet temperature.

Refrigerator: The temperature differential for the compressor to turn on and off is 6°F (±4.4°C) of the temperature setpoint. For example, for a refrigerator temperature setpoint of 36°F (2°C), the compressor comes on at 42°F (5.5°C), and the compressor goes off at 36°F (2°C).

Freezer: The temperature differential for the compressor to turn on and off is 4.7°F (±2.6°C) of the temperature setpoint. For example, for a freezer temperature setpoint of -4°F (-20°C), the compressor comes on at 1°F (-17°C), and the compressor goes off at -4°F (-20°C).

If necessary, adjust the temperature setpoint temperature as follows:

- 1) To change the temperature setpoint, press and release the up or down button. SP flashes with the current temperature setpoint. Press the up or down button until the desired value is displayed. After 10 seconds, the display returns to the current cabinet temperature and the temperature setpoint is saved. **NOTICE! Do not adjust the temperature setpoint more than 2°F (1°C) at a time. Allow the temperature to stabilize for a minimum of 8 hours before making further temperature setpoint adjustments.**

Model	Temperature Setpoint Range	Factory Default Temperature Setting
Refrigerator	DATA PENDING	
Freezer	-10°F to +12°F (-24°C to -11°C)	-2°F (-19°C)

3. Light Control for Glass Door Models

Glass door models feature lights that are controlled by the "P" button located on the control module. See Fig. 38. Press and hold the "P" button for 3 seconds to turn the light on or off.

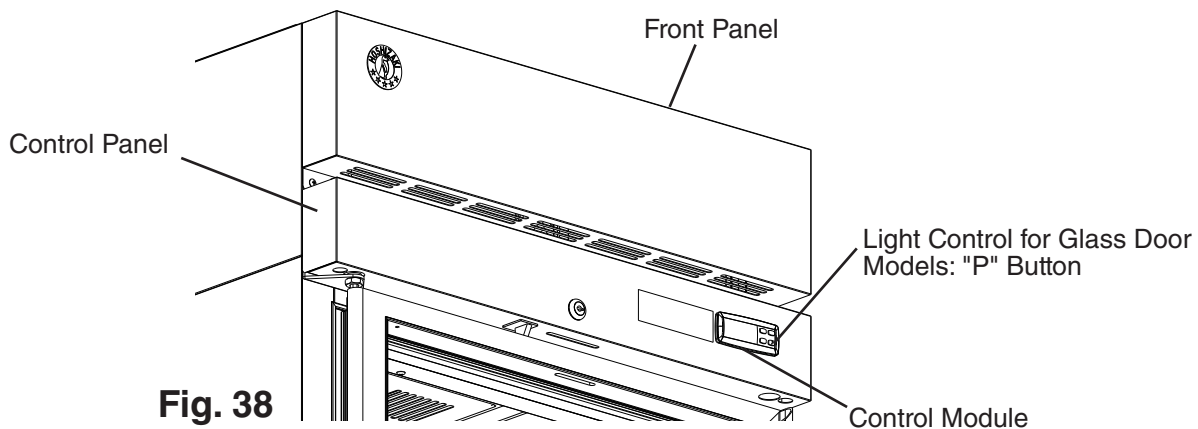





Fig. 38

D. Control Module Buttons and Icons

Control module icons inform you of energized components and if the appliance is in alarm.

Control Module Icons	
Icon	Meaning
	Compressor Compressor running.
	Defrost Appliance is in defrost cycle. See "II.E. Defrost" for details.
	Evaporator Fan Motor Evaporator fan motor is running. Evaporator fan motor de-energizes when door is open.
	Alarm Appliance is in alarm. Icon flashes with audible alarm. See "II.G. Alarm Safeties" for details.

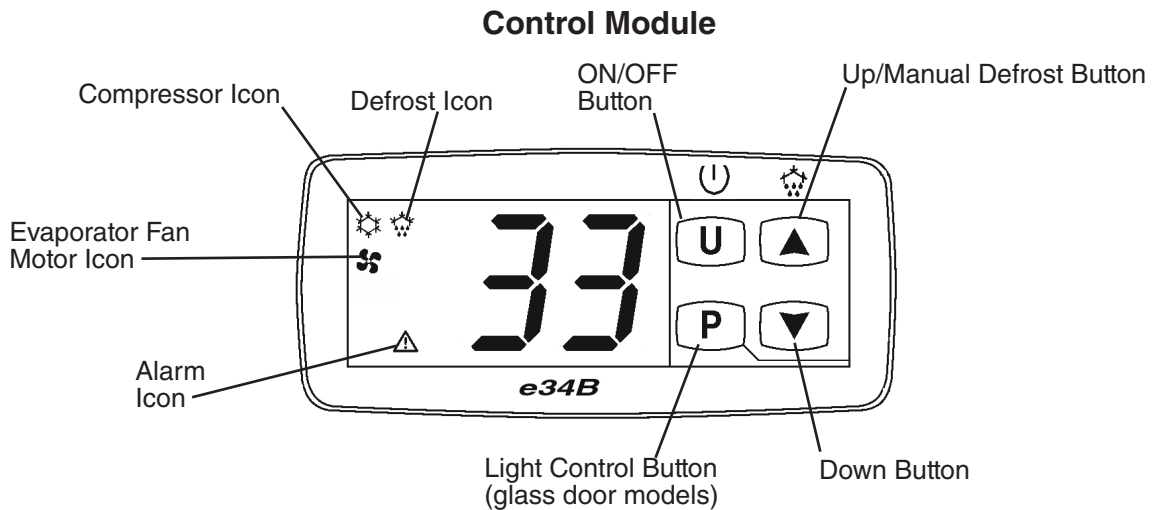

Fig. 39

E. Defrost

⚠ DANGER

Risk of Fire or Explosion. Flammable Refrigerant Used.

- Do not use mechanical devices to defrost.
- Do not puncture refrigerant tubing. Risk of fire or explosion due to puncture of refrigerant tubing; follow handling instructions carefully.

Risque De Feu Ou D'Explosion. Le Frigorigène Est Inflammable.

- Ne pas utiliser d'appareils mécaniques pour dégivrer le réfrigérateur.
- Ne pas perforer la tubulure contenant le frigorigène. Risque de feu ou d'explosion si la tubulure contenant le frigorigène est perforée; suivre les instructions de manutention avec soin.

1. Refrigerators

DATA PENDING

2. Freezers

Heated Defrost: Freezers utilize a time-initiated, heated defrost.

- Defrost Initiation: When the appliance is plugged into the electrical outlet, the 5-hr. defrost timer starts. Once the 5-hr. defrost timer or the 4-hr. continuous compressor run timer terminates, defrost initiates if the defrost thermistor is at or below 50°F (10°C). If the defrost thermistor is not at or below 50°F (10°C), the control module continues in cooling mode until the termination of the next 5-hr. defrost timer or the 4-hr. continuous compressor run timer.

The maximum defrost time is 1 hr.

- Defrost Termination: Once the defrost thermistor reaches 104°F (40°C), defrost terminates. If 104°F (40°C) is not achieved, defrost continues until the 1-hr. maximum timer terminates. The 5 hr. defrost timer and 4-hr. continuous compressor run timer reset once defrost terminates. 3-min. compressor delay timer and 4-min. evaporator fan motor delay timer start (drip time).
- The compressor energizes 3-min. after the defrost heater de-energizes and the evaporator fan motor(s) energize 4-min. after the defrost heater de-energizes (drip time).
- During defrost dEF is displayed. Once defrost terminates, Pdf is displayed and the defrost icon flashes during the 3-min. compressor delay time. Once the 3-min. compressor delay timer terminates, cabinet temperature returns to display, compressor icon turns on. Evaporator fan motor icon starts flashing. Once the evaporator fan motor energizes and icon turns solid.

Note: If the defrost thermistor is above 14°F (-10°C) the evaporator fan motor de-energizes until the defrost thermistor drops to 14°F (-10°C).

3. Manual Defrost

To initiate a manual defrost, press and hold the up button for 5 seconds.

To terminate a defrost, press and hold the up button for 5 seconds.

Note: Manual defrost only initiates when evaporator temperature (defrost thermistor) is at or below 50°F (10°C).

F. Food Storage

WARNING

- This appliance is designed only for storage of food. Employ sanitary methods. Use for any other purposes (for example, storage of chemicals or medical supplies such as vaccine and serum) could cause deterioration of stored items.
- Do not block the cabinet air inlet or outlet, otherwise, cooling performance may be reduced.
- Do not tightly pack the cabinet. Allow some space between items to ensure good air flow. Also allow space between items and interior surfaces.
- Do not place any product on the floor of the cabinet. All product must be placed on properly installed shelves.
- Do not put warm or hot foods in the cabinet. Let them cool first, or they will raise the cabinet temperature and could deteriorate other foods in the cabinet or overload the appliance.
- All foods should be wrapped in plastic film or stored in sealed containers. Otherwise, foods may dry up, pass their smells onto other foods, cause frost to develop, result in poor appliance performance, or increase the likelihood of cross-contamination. Certain dressings and food ingredients, if not stored in sealed containers, may accelerate corrosion of the evaporator, resulting in failure.
- Do not store items near the air outlet. They might freeze up and crack or break causing a risk of injury or contamination of other food.

G. Alarm Safeties

Alarm signals are designed to protect the appliance and food product. These alarms give information or warnings in the event the appliance is operating out of acceptable parameters. Should one of the alarms occur, follow the instructions in the table below to address the alarm. The alarm code and alarm icon flash with audible alarm.

Alarm Signals		
Alarm Code	Problem	Corrective Action/Reset Details
op	<p>Door Switch Alarm: Door has remained open for more than 2 minutes.</p> <p>Door Is Open or The Door Switch has failed.</p>	<p>If obvious corrections such as closing doors does not correct the alarm, call a qualified service technician.</p> <p>Steady tone. To silence the alarm, press and release any button.</p>
(-)E01	<p>Cabinet Thermistor Malfunction Alarm</p> <p>Cabinet thermistor has failed.</p>	<p>Call a qualified service technician.</p> <p>Steady tone. To silence the alarm, press and release any button.</p> <p>Appliance cycles 5 min. on, 5 min. off.</p> <p>E1 - Cabinet thermistor out of place or open.</p> <p>-E1 - Cabinet thermistor shorted.</p>
(-)E02	<p>Defrost Thermistor Malfunction Alarm</p> <p>Defrost thermistor has failed.</p>	<p>Call a qualified service technician.</p> <p>Steady tone. To silence the alarm, press and release any button.</p> <p>Appliance cycles on and off with cabinet thermistor. Defrost cycles for 25 min. every 6 hr.</p> <p>E2 - Defrost thermistor out of place or open.</p> <p>-E2 - Defrost thermistor shorted.</p>
Hi	<p>High Temperature Alarm</p> <p>Refrigerator:</p> <p style="text-align: center;">DATA PENDING</p> <p>Freezer: Cabinet temperature has remained above 26°F (-3.3°C) for more than 1 hour.</p>	<p>If obvious corrections such as closing doors and cleaning the air filter and/or condenser do not bring temperature back in range, call a qualified service technician.</p> <p>Steady tone. To silence the alarm, press and release any button.</p> <p>Automatically resets when temperature returns to normal.</p>
Lo	<p>Low Temperature Alarm</p> <p>Refrigerator:</p> <p style="text-align: center;">DATA PENDING</p> <p>Freezer: Cabinet temperature has remained below -23°F (-30.6°C) for more than 1 hour.</p>	<p>If obvious corrections do not bring the temperature back in range, call a qualified service technician.</p> <p>Steady tone. To silence the alarm, press and release any button.</p> <p>Automatically resets when temperature returns to normal.</p>

H. Safety Devices

1. Compressor External or Internal Overload

If combined temperature/amperage value is above the limit specified by the compressor manufacturer, the compressor overload operates independently to turn off the compressor. The compressor overload de-energizes the compressor until the temperature/amperage value returns to an acceptable level.

2. Short-Cycle Protection

There is a 2-minute minimum off-time for the compressor.

Note: Time may vary with compressor overload or high-pressure switch activation.

3. High-Pressure Switch

If pressure on the high-side of the appliance exceeds Hoshizaki specifications, the high-pressure switch activates and interrupts the compressor circuit, de-energizing the compressor until the pressure returns to an acceptable level.

I. Cooling Performance

Be sure the appliance is properly installed and located for optimum cooling performance. If cooling performance is not at its optimum level, check the following items:

- Door(s) opened too often.
- Door(s) left open. Close.
- Dirty air filter and/or condenser. Clean.
- Cabinet too tightly packed or cabinet air inlet/outlet blocked. Allow some space between items to ensure good air flow.
- Warm or hot foods inside. Take them out until they cool down more.
- Ambient temperature too high. Avoid installation near high heat producing equipment or exposure to direct sunlight.
- Temperature setpoint too high. Readjust it to a lower temperature.
- Appliance in defrost cycle. The cabinet temperature may rise temporarily during the defrost cycle, but this will not affect the food inside.

J. Cabinet Condensation

In the event condensation develops on the cabinet exterior, check the following items:

- Door(s) left open. Close.
- Ambient humidity too high. In high humidity areas it may be necessary to wipe off the cabinet frame occasionally.

IV. Maintenance

This appliance must be maintained in accordance with the instruction manual and labels provided with the appliance. Consult with your local Hoshizaki Certified Service Representative about maintenance service. To obtain the name and phone number of your local Hoshizaki Certified Service Representative, visit www.hoshizakiamerica.com.

⚠ WARNING

- Only qualified service technicians should service the appliance.
- Before starting a maintenance procedure, press the "U" button to turn "OFF" the appliance and unplug the appliance, to prevent electric shock or injury by moving parts. To reduce the risk of electric shock, do not touch the plug with damp hands.
- Before cleaning the appliance, move all foods into another clean refrigerator or freezer.

A. Maintenance Schedule

The maintenance schedule below is a guideline. More frequent maintenance may be required depending on the appliance's environment, and local sanitation regulations.

Maintenance Schedule		
Frequency	Area	Task
Bi-Weekly	Air Filters	Inspect. Wash with warm water and neutral cleaner if dirty.
Bi-Yearly	Condenser	Inspect. Clean if necessary by using a brush or vacuum cleaner. More frequent cleaning may be required depending on location.
Annually	Condenser Wick	The condenser wick must be cleaned at least once a year. More frequent cleaning may be required in some conditions to maintain proper flow.

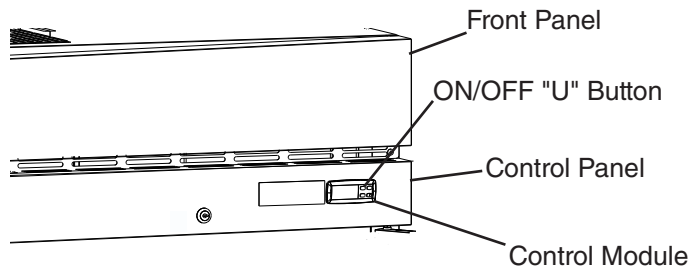

Fig. 40

B. Cleaning Instructions

WARNING

- Before starting a cleaning procedure, press the "U" button to turn "OFF" the appliance and unplug the appliance, to prevent electric shock or injury by moving parts. To reduce the risk of electric shock, do not touch the plug with damp hands.
- Before cleaning the appliance, move all foods into another clean refrigerator or freezer.
- Do not splash, pour, or spray water directly onto or into the appliance. This might cause short circuit, electric shock, corrosion, or failure.
- Carefully follow instructions provided with cleaning and sanitizing products.

NOTICE

- To prevent damage to the plastic surfaces, do not use the following: hot water, thinner, benzine, alcohol, petroleum, soap powder, polishing powder, alkaline cleaner, acid, scouring pad and especially those strong cleaners for use on a ventilating fan or a cooking range.
- To prevent corrosion and damage to stainless steel surfaces, use only products formulated for use on stainless steel appliances. Do not use steel wool, abrasive products, or products containing sodium hypochlorite (chlorine bleach).
- Use a clean cloth for cleaning.

1. Air Filter

Check the air filter at least twice a month. When clogged, use warm water and a neutral cleaner to wash the filter.

2. Exterior

Wipe the exterior occasionally with a clean, soft cloth. Use a damp cloth containing a neutral cleaner to wipe off oil or dirt buildup. Clean any rust colored spots using a non-abrasive cleanser.

3. Cabinet Interior

Spills should be wiped up promptly to avoid unpleasant odors. The cabinet interior should be cleaned periodically with a mild soap or detergent and warm water. **NOTICE! Do not use hot water to clean the cabinet interior.**

4. Door Gaskets

Door gaskets should be cleaned regularly with mild soap and warm water to remove dirt and grease.

5. Shelves

Remove and clean regularly.

6. Glass Door

Wipe occasionally with a clean, soft cloth. Use a damp cloth containing a neutral cleaner to wipe off oil or dirt buildup.

7. Condenser

The condenser must be cleaned at least once a year. More frequent cleaning may be required in some conditions. Use a brush or vacuum cleaner to clean the condenser as required.

8. Condensate Wick (Except DT1A-HS and Freezer on DT2A-FS)

The condensate wick must be cleaned at least once a year. More frequent cleaning may be required in some conditions to maintain proper flow. Follow the steps below.

- 1) Unplug the appliance from the electrical outlet. **WARNING! To reduce the risk of electric shock, do not touch the plug with damp hands.**
- 2) Remove the wick from the retainers. See Fig. 41.
- 3) Clean or replace the wick. **NOTICE! If the wick is clogged/deteriorating replace.**
- 4) Replace the wick in its correct position.
NOTICE! Be sure the wick is positioned into the condensate pan.
- 5) Plug the appliance back in.

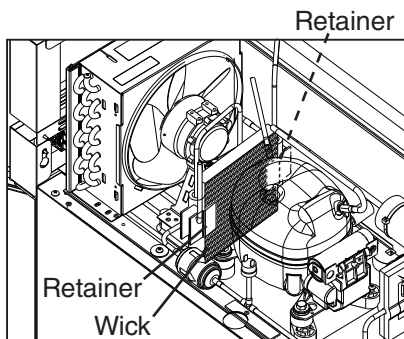
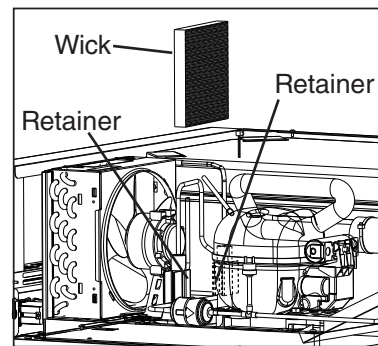

Fig. 41



9. Power Supply Connection

If the plug or power cord is damaged, contact your local Hoshizaki service representative or local Hoshizaki distributor immediately and ask for repairs.

All other maintenance or service on this appliance should be performed in accordance with the Hoshizaki Service Manual by a qualified service technician.

V. Preparing the Appliance for Periods of Non-Use

When shutting down the appliance for periods of non-use, follow the instructions below.

⚠ WARNING

- When preparing the appliance for long storage, prevent the doors or drawers from closing to reduce the risk of children getting trapped.
- Risk of electric shock. Appliance in the off position does not de-energize all loads. Use extreme caution and exercise safe electrical practices.
- To reduce the risk of electric shock, do not touch the plug with damp hands.

NOTICE

When preparing the appliance for long storage, clean the appliance. See "III.A. Cleaning" for details.

- 1) Before shutting down the appliance, move the stored food into another refrigerator or freezer.
- 2) Press and release the "U" button on the control module, then unplug the appliance from the electrical outlet. **IMPORTANT! Perimeter heater (freezer models only), mullion heater (except 1-section refrigerator models), and drain tube heater (freezer models only), energize once appliance is plugged into the electrical outlet and remain energized even while the control module is in "OFF" mode. Unplug the appliance from the electrical outlet to de-energize the heaters.**

VI. Decommissioning and Disposal



R-290 Class A3 Flammable Refrigerant Used

⚠ DANGER

Risk of Fire or Explosion. Flammable Refrigerant Used.

- Only qualified service technicians should install and service the appliance.
- Follow handling instructions carefully in compliance with national regulations.
- Dispose of properly in accordance with federal or local regulations.
- Do not puncture refrigerant tubing. Risk of fire or explosion due to puncture of refrigerant tubing; follow handling instructions carefully.
- Be sure to follow the full Decommissioning and Disposal information located in the Service Manual for this model. The Service Manual is available at www.hoshizakiamerica.com.

Risque D'Incendie ou D'Explosion. Fluide Frigorigène Inflammable Utilisé.

- Seuls des techniciens de service qualifiés doivent installer et entretenir l'appareil.
- Suivre attentivement les instructions de manutention conformément aux règlements nationaux.
- Mettre au rebut conformément aux règlements fédéraux ou locaux.
- Ne pas perforer la conduite de fluide frigorigène. Risque d'incendie ou d'explosion en cas de perforation d'une canalisation de fluide frigorigène; suivez attentivement les instructions de manutention.
- Veiller à respecter l'ensemble des informations relatives à la mise hors service et à la mise au rebut figurant dans le manuel d'entretien de ce modèle. Le manuel d'entretien est disponible à l'adresse suivante: www.hoshizakiamerica.com.

HOSHIZAKI AMERICA, INC.

618 Hwy. 74 South, Peachtree City, GA 30269 USA (P) 770.487.2331 (F) 770.487.3360 hoshizakiamerica.com 1A8118-011